

EXAKT
MFG CO

DENTAL
INSTRUMENTS



**ORIGINAL
INSTRUMENTS
MANUFACTURER**

**ORIGINAL
BRAND
MANUFACTURER**

50

Extracting Forceps,American Pattern
Zahnzangen,Amerikanische Form
Daviers,Forme americaine
Forceps de extrozione,forma americana
page 001 to 016

51

Extracting Forceps,English Pattern
Zahnzangen,Englische Form
Daviers,Forme anglaise
Forceps dentales,forma inglese
Pinze per estrazione,forma inglese
page 017 to 043

52

Root Elevators
Wurzelheber
Elevateurs a racines
Botadores para raices
Leve per radici
page 042 to 057

53

Bone Files
Bone-Dateien
Archivos de huesos
Fichiers d'os
Bone Files
page 058 to 060

54

Dental Probes
Zahnsonden
Sondes Dentales
Sondes Dentaires
Sonde Dentali
page 061 to 061

55

Enamel Instruments
Emaile-Instrumente
Instrumentos de esmalte
Instruments d'email
Strumenti per smalto
page 064 to 068

56

Dental Scalers
Zahnsteinentferner
Escaladores dentales
Scalers dentaires
Scaler dentali
page 069 to 087

57

Bone Curettes
Knochenkuretten
Curetas de hueso
Curettes osseuses
Curettes d'ossa

page 086 to 092

58

Excavators
Bagger
Excavadoras
Pelles
Escavatori

page 093 to 098

59

Wax Proclein
Wachs-Porzellan
Cera Porcelana
Cire Porcelaine
Cera Porcellana

page 099 to 104

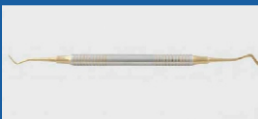
60

Filling Instruments
Fullungsinstrumente
Actos de llenado
Instruments de remplissage
Strumenti di riempimento

page 105 to 116

61

Gingivectomy Knives
Gingivektomie Messer
Cuchillos de gingivectomia
Couteaux de gingivectomie
Coltelli per gengivectomia

page 117 to 119

62

Cement Spatulas
Zementspatel
Espatulas de cemento
Spatules de ciment
Spatole di cemento

page 120 to 125

63

Mouth Mirrors
Mundspiegel
Espejos Bucales
Bouche Miroirs
Bocca specchi

page 126 to 129

64



Amalgam Instruments
Amalgam Instrumente
Instrumentos de amalgama
Instruments Amalgam
Strumenti amalgama

page 130 to 132

65



Matrix Retainers
Matrix-Halterungen
Retenedores de matrices
Retenue de matrice
Matrix Retainers

page 133 to 141

66



Hemostatic Forceps
Arterienklemmen
Pincas Hemostaticas
Pinzashemostaticas
Pinze Emostatiche

page 142 to 149

67



Towel Clamps
Handtuchklammern
Abrazaderas de toalla
Pincas a serviettes
Morsetti per asciugamano

page 150 to 152

68



Needle Holders
Nadelhalter
Porte-aiguilles
Porta-agujcs
port'aghi

page 153 to 162

69



Retractors
Wundhaken
Ecarteurs
Separadores
Divaricatori

page 163 to 168

70

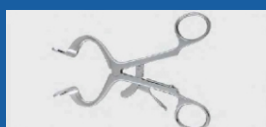

Mouth and Tongue
Mund und Zunge
Boca y la lengua
Bouche et langue
Bocca e la lingua

page 126 to 129

71

Scissors
Schere
Tijeras
Les Ciseaux
Forbici

page 174 to 193

72

Micro Scissors
Mikroschere
Micro tijeras
Micro-ciseaux
Micro forbici

page 194 to 196

73

Orthodontics
Kieferorthopadie
Ortodoncia
Orthodontie
Ortodonzia

page 197 to 214

74

Bone Rongeurs
Knochen Rongeur
Rongeurs de hueso
Os Rongeurs
Bone Rongeurs

page 215 to 218

75

Forceps
Zange
Forceps
Forcipes
Forcipe

page 219 to 227

76

Scalpel Handles
Skalpgriffe
Manches de bistouris
Mangos de Bisturios
Manici per bisturi

page 228 to 230

77

Mallets
Schlagel
Mazos
Maillets
Mallets

page 231 to 234

78



Cassettes
Kassetten
Cassettes
Cassettes
Cassette

page 235 to 239

79



Cylinder cartridge syringe
Zylinder-Ampullenspritze
Seringue a ampoule cylindrique
Jeringo para cartucho ampollas
Siringe ampollare a cilindro

page 240 to 246

80



Impression Trays
Abdruckloffel
Porte empreintes
Cubetas para impresiones
Portaimpronte

page 247 to 259

81



Articulators
Artikulatoren
Articuladores
Articulateurs
Articolatori

page 260 to 270

82



Holloware
Holloware
Holloware
Platerie
Holloware

- EN** Extracting Forceps, American Pattern
- DE** Zahnzangen, Amerikanische Form
- ES** Daviers, forme américaine
- FR** Forceps de extraction, forma americana
- IT** Pinze per estrozione, forma americana

Page 01 to 15

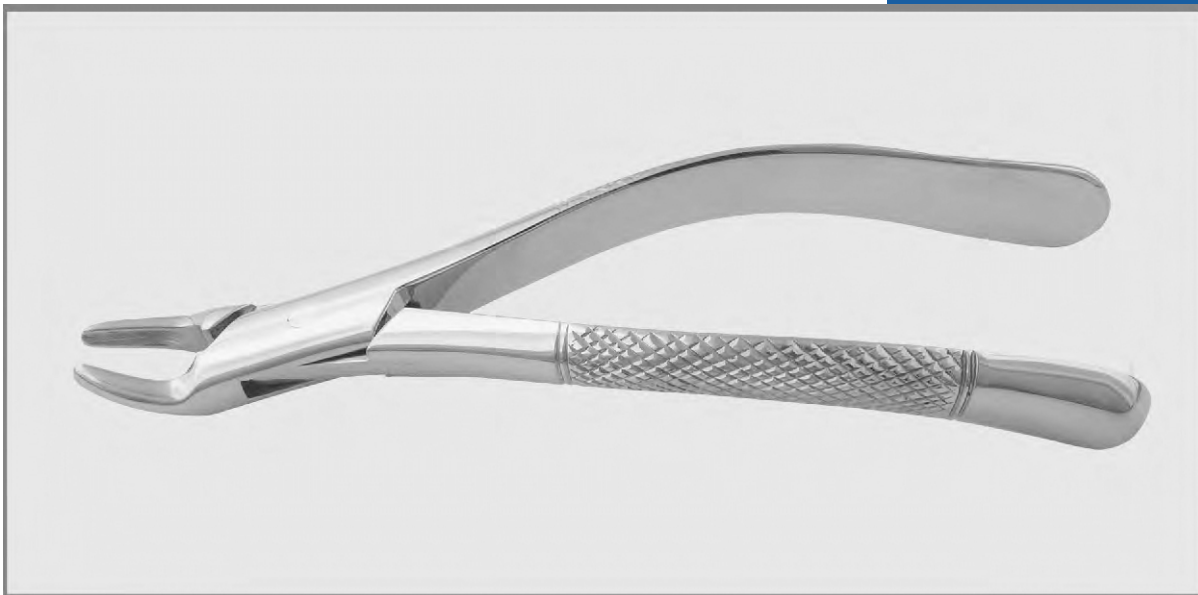



Fig. 1



RAS-0,50-1001



RAS-0,50-1002



RAS-0,50-1003



HENAHAN
Fig. 1 A



Fig. 1 B



JMLWAUKEE
Fig. 3



RAS-0,50-1004

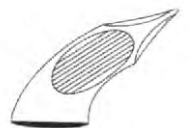

RAS-0,50-1005



WOOD-WARD
Fig. 3 FH



RAS-0,50-1006

WOOD-WARD
Fig. 3 FS



RAS-0,50-1007

PHYSICK
Fig. 5

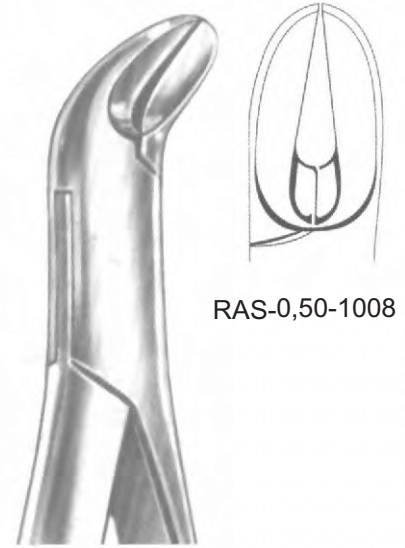

RAS-0,50-1008

Fig. 6



RAS-0,50-1009

Fig. 10 H



RAS-0,50-1010

Fig. 10 S



RAS-0,50-1011

HARRIS
Fig. 15



RAS-0,50-1012

HARRIS
Fig. 16



RAS-0,50-1013

Fig. 16 S

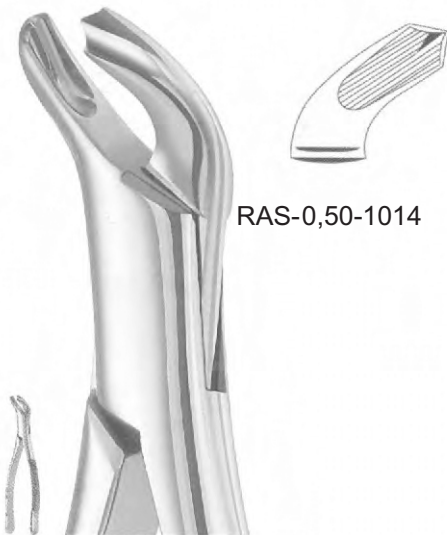

RAS-0,50-1014

Fig. 17

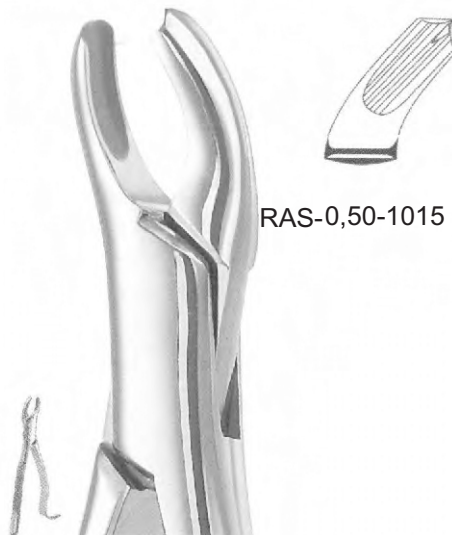

RAS-0,50-1015

HARRIS
Fig. 18 L



RAS-0,50-1016

HARRIS
Fig. 18 R



RAS-0,50-1017

Fig. 23

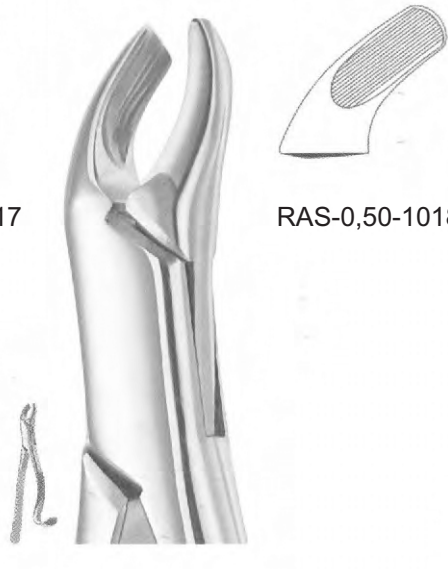

RAS-0,50-1018

Fig. 24

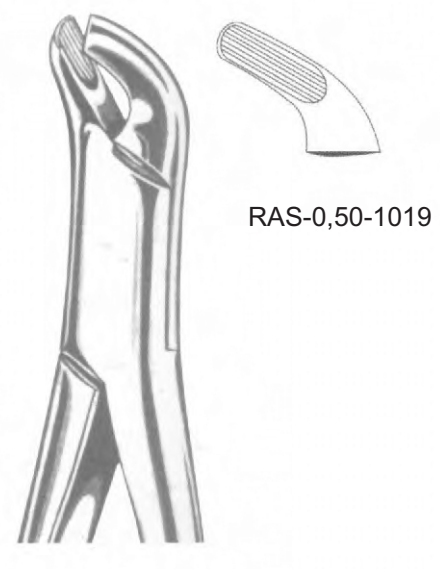

RAS-0,50-1019

Fig. 27



RAS-0,50-1020

PARMLY
Fig. 32



RAS-0,50-1021

PARMLY
Fig. 32 A

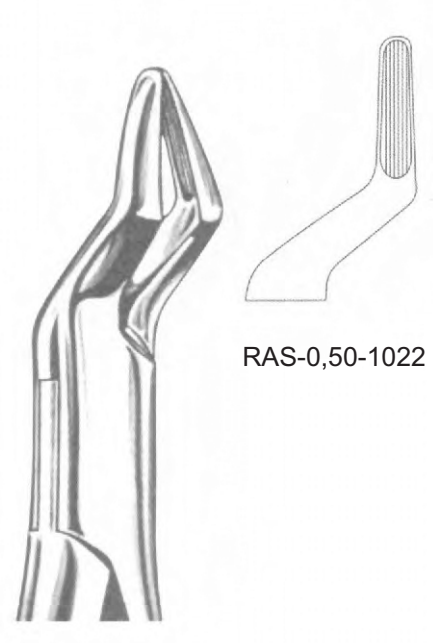

RAS-0,50-1022

Fig. 35

EN Extracting Forceps American Pattern
DE Extraktionszange amerikanisches Muster
ES Extraer el patrón estadounidense de fórceps
FR Forceps d'extraction modèle américain
IT Estrazione del forcipe modello americano



RAS-0,50-1023

Fig. 53 L



RAS-0,50-1024

Fig. 53 R



Fig. 62



RAS-0,50-1025



Fig. 65

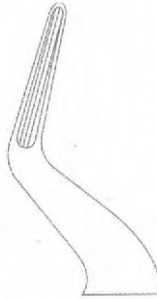

RAS-0,50-1026



TOMES
Fig. 69



RAS-0,50-1027



THOMAS
Fig. 85



RAS-0,50-1028



THOMAS
Fig. 85 A



RAS-0,50-1029

EXTRACTION



NEVIUS
Fig. 88 L



RAS-0,50-1030



NEVIUS
Fig. 88 R

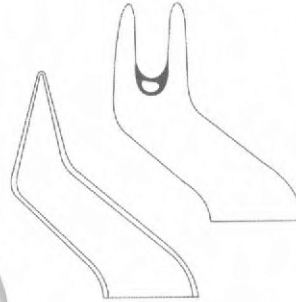

RAS-0,50-1031



KELLS
Fig. 99 A

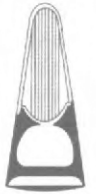

RAS-0,50-1032



KELLS
Fig. 99 C



RAS-0,50-1033



HULL
Fig. 101



RAS-0,50-1034



Fig. 103

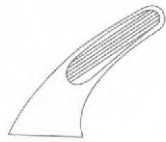

RAS-0,50-1035



Fig. 10 H



RAS-0,50-1036



Fig. 10 S



RAS-0,50-1037



CRYER
Fig. 150



RAS-0,50-1038



CRYER
Fig. 150 A



RAS-0,50-1039



Fig. 150 X



RAS-0,50-1040

EN Extracting Forceps American Pattern
 DE Extraktionszange amerikanisches Muster
 ES Extraer el patrón estadounidense de fórceps
 FR Forceps d'extraction modèle américain
 IT Estrazione del forcipe modello americano



Fig. 150 AB

Fig. 150 AS

CRYER
Fig. 150 S



CRYER
Fig. 151

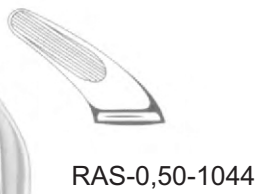

CRYER
Fig. 151 A



Fig. 151 X

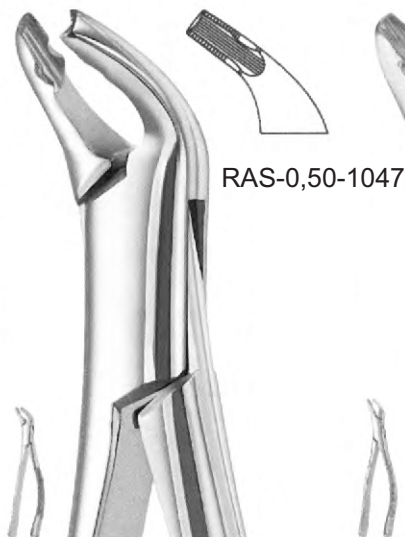

CRYER
Fig. 151 AB

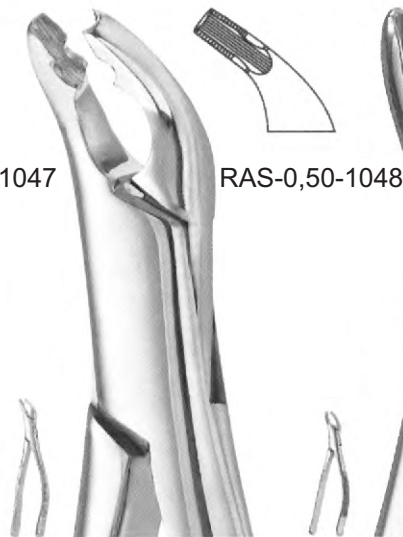
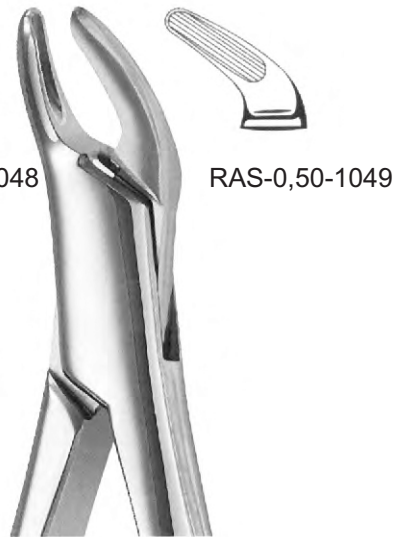
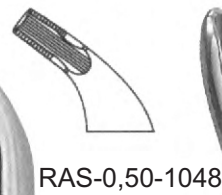

Fig. 151 AS



CRYER
Fig. 151 S





Fig.201

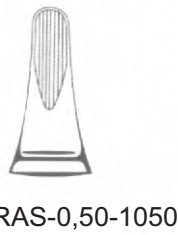

RAS-0,50-1050



Fig.203

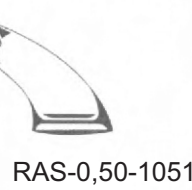

RAS-0,50-1051



Fig.217



RAS-0,50-1052



Fig.210 H

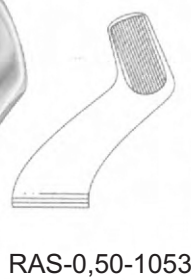

RAS-0,50-1053



Fig.210 S



RAS-0,50-1054

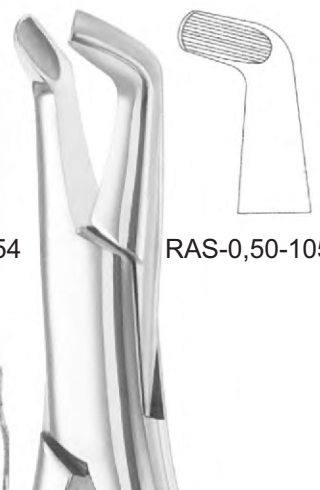

Fig.222



RAS-0,50-1055



EN Extracting Forceps American Pattern
DE Extraktionszange amerikanisches Muster
ES Extraer el patrón estadounidense de fórceps
FR Forceps d'extraction modèle américain
IT Estrazione del forcipe modello americano

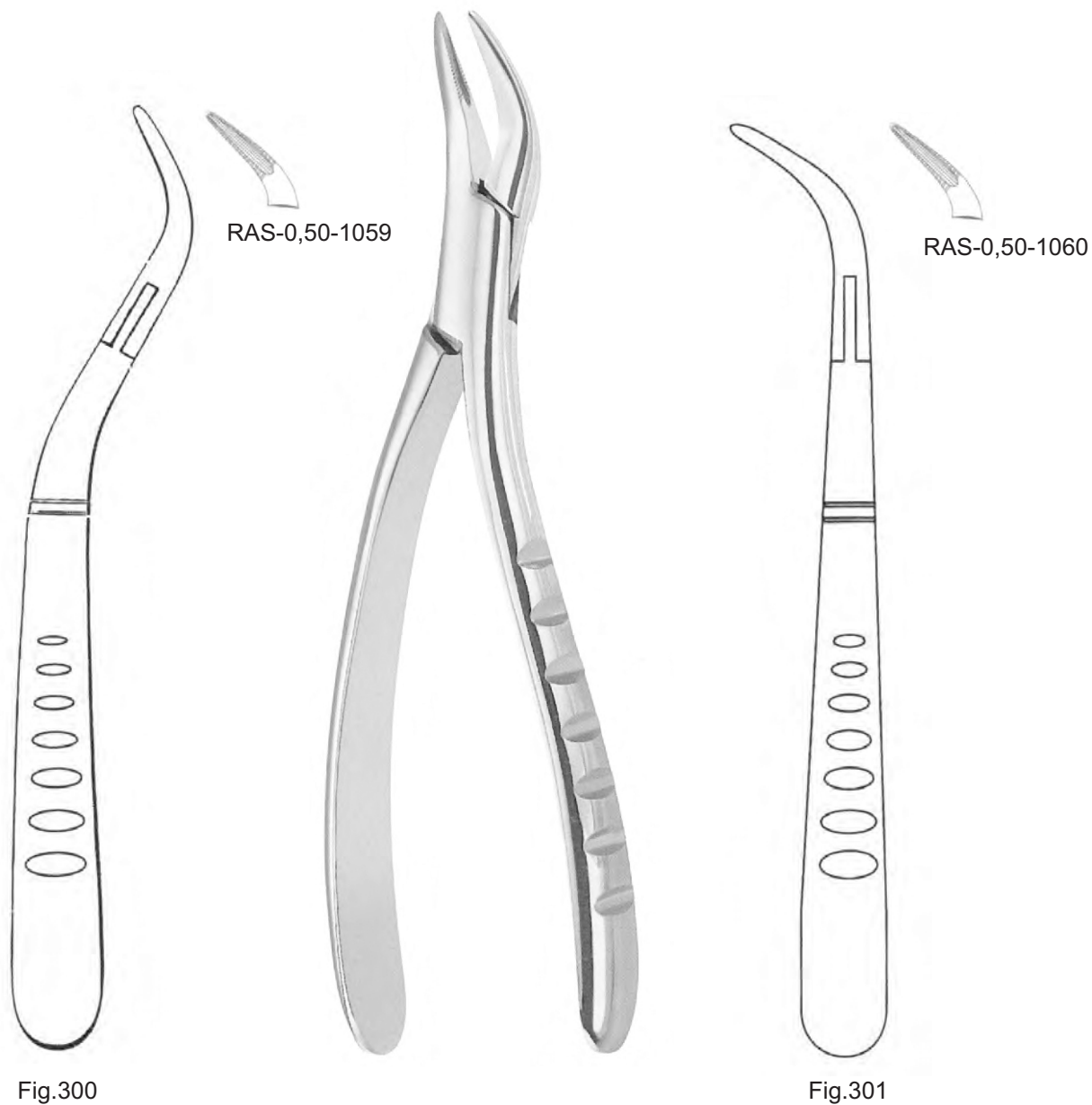

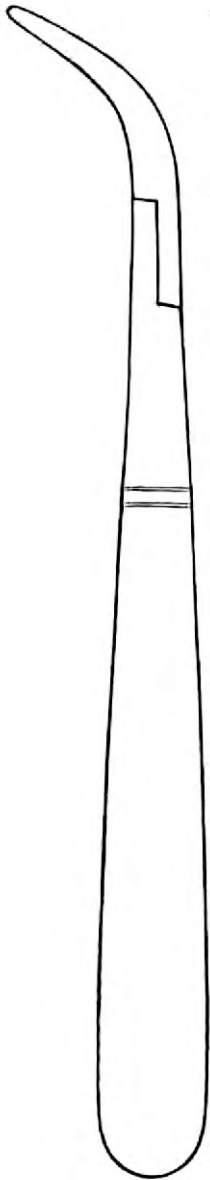

RAS-0,50-1061
WITZEL
Fig.501



RAS-0,50-1062
WITZEL
Fig.502

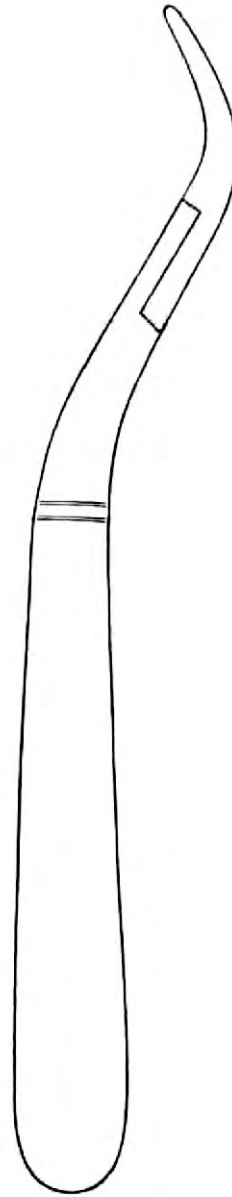



Fig. 17 SK

RAS-0,50-1063



Fig. 23 SK

RAS-0,50-1064



Fig. 150 Sk

RAS-0,50-1065



Fig. 151 Sk

RAS-0,50-1066

- EN** Extracting forceps, English pattern
- DE** Zahnzangen, Englische Form
- ES** Daviers, forme anglaise
- FR** Fórceps dentales, forma inglesa
- IT** Pinze per estrazione, forma inglese

Page 16 - 38



EN Extracting Forceps English Pattern
 DE Zange extrahieren englisches Muster
 ES Extracto de fórceps patrón inglés
 FR Forceps d'extraction modèle anglais
 IT Estrazione del forcipe modello inglese



Fig. 1

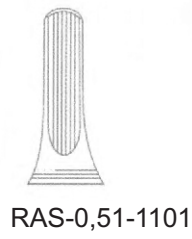

Fig. 2

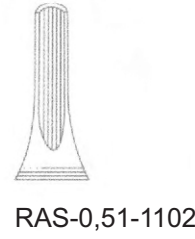

Fig. 3

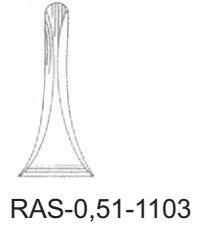

Fig. 4



Fig. 7



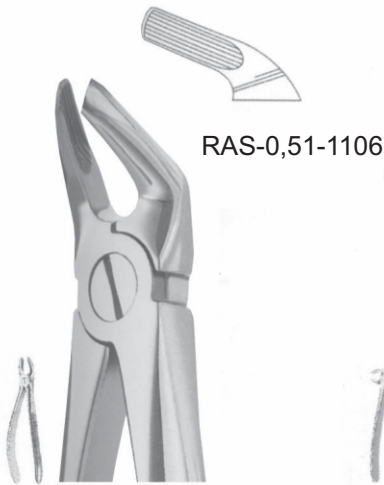

Fig. 8



Fig. 13



RAS-0,51-1107



Fig. 17



RAS-0,51-1108



Fig. 18



RAS-0,51-1109



Fig. 18 A



RAS-0,51-1110



Fig. 19



RAS-0,51-1111

EN	Extracting Forceps English Pattern
DE	Zange extrahieren englisches Muster
ES	Extracto de fórceps patrón inglés
FR	Forceps d'extraction modèle anglais
IT	Estrazione del forcipe modello inglese

EXTRACTION



Fig. 20



Fig. 21



Fig. 22



Fig. 23



Fig. 24



Fig. 29



Fig. 29 N



Fig. 30



Fig. 31



Fig. 32

EN	Extracting Forceps English Pattern
DE	Zange extrahieren englisches Muster
ES	Extracto de fórceps patrón inglés
FR	Forceps d'extraction modèle anglais
IT	Estrazione del forcipe modello inglese



Fig. 33



RAS-0,51-1122



Fig. 33 A



RAS-0,51-1123



Fig. 33 C



RAS-0,51-1124



Fig. 33 M



RAS-0,51-1125



Fig. 33 W



RAS-0,51-1126



Fig. 34



Fig. 35



Fig. 36

EXTRACTION



Fig. 41

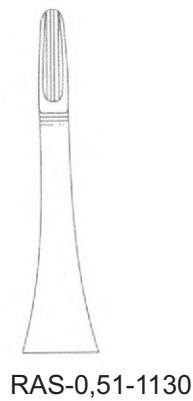

Fig. 44

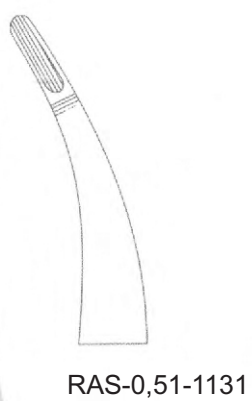

Fig. 44 F

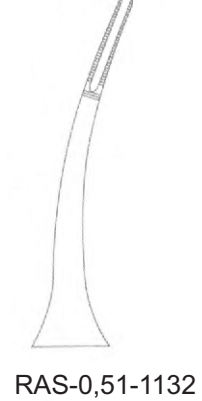

Fig. 45



Fig. 45 F

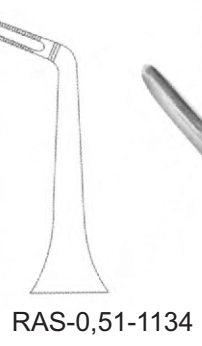

Fig. 46 L



- EN Extracting Forceps English Pattern
- DE Zange extrahieren englisches Muster
- ES Extracto de fórceps patrón inglés
- FR Forceps d'extraction modèle anglais
- IT Estrazione del forcipe modello inglese

EXTRACTION



Fig. 51 M



Fig. 52

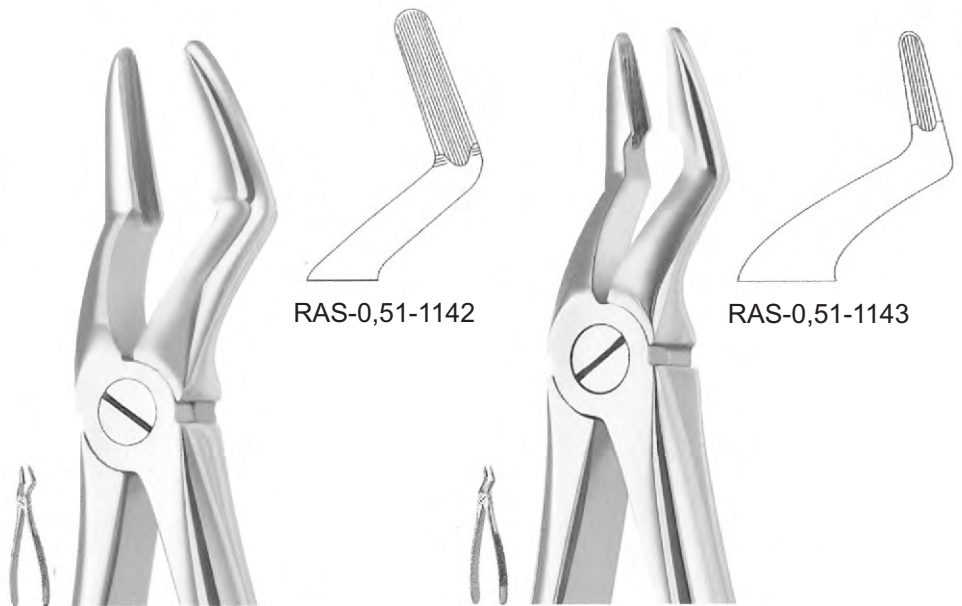

Fig. 52 A

Fig. 53



Fig. 55



RAS-0,51-1144

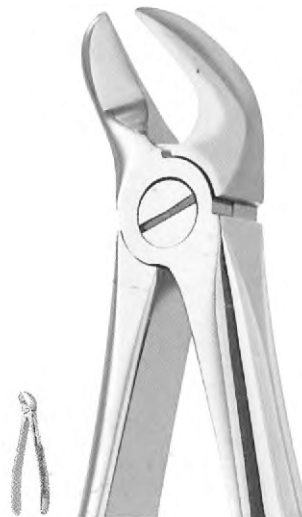
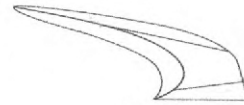
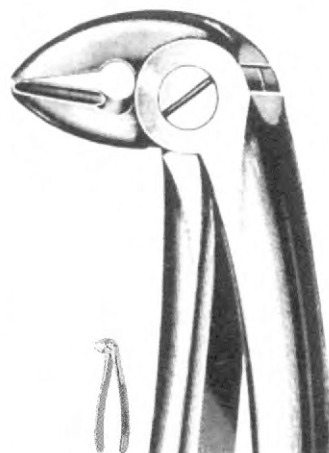

Fig. 56



RAS-0,51-1145

INSTRUMENTS CORPORATION



BUSCH
Fig. 59

breit
broad

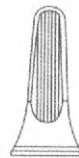

RAS-0,51-1146



BUSCH
Fig. 60

schmal
narrow



RAS-0,51-1147

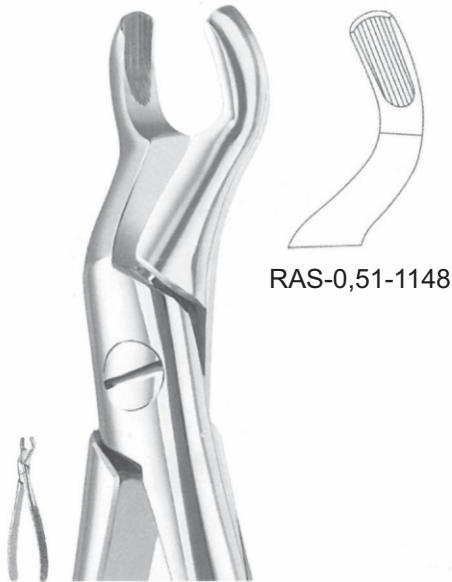

RAS-0,51-1148

Fig. 67

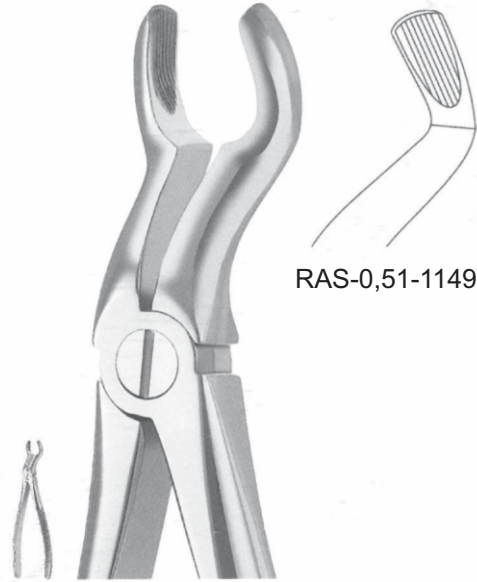

RAS-0,51-1149

Fig. 67 A

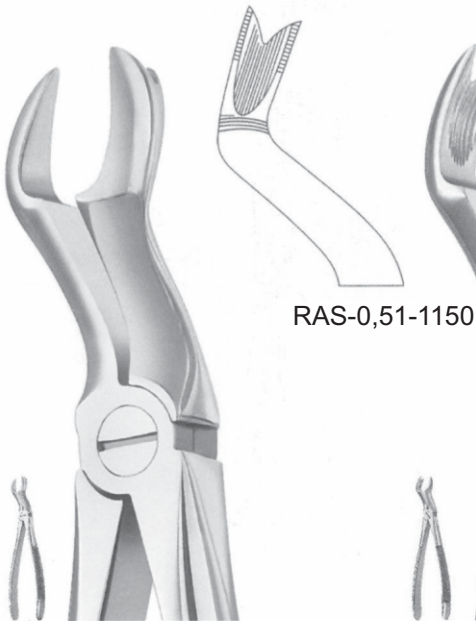

RAS-0,51-1150

Fig. 67 LX

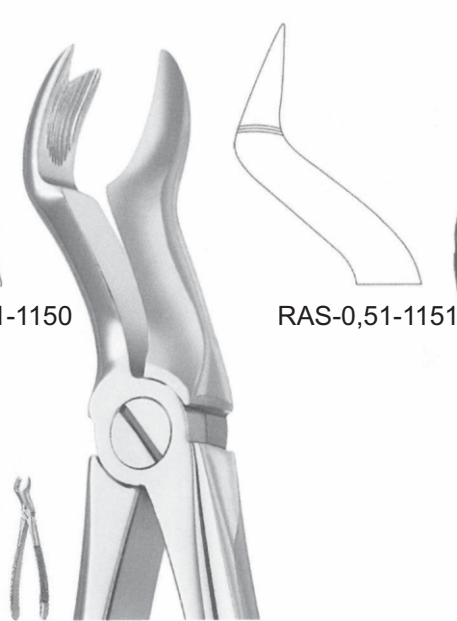

RAS-0,51-1151

Fig. 67 RX



RAS-0,51-1152

RYDING
Fig. 68



Fig. 73



Fig. 74

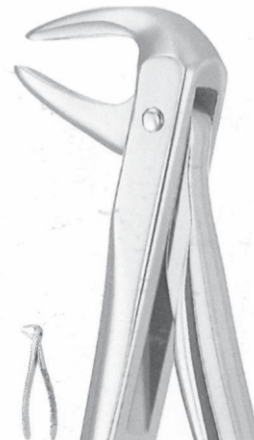

Fig. 74 M



Fig. 74N



Fig. 75



EN	Extracting Forceps English Pattern
DE	Zange extrahieren englisches Muster
ES	Extracto de fórceps patrón inglés
FR	Forceps d'extraction modèle anglais
IT	Estrazione del forcipe modello inglese



RAS-0,51-1158

LAWRENCE-READ
Fig. 76

RAS-0,51-1159

LAWRENCE-READ
Fig. 76 N



Fig. 79



Fig. 79 A



Fig. 86 A



Fig. 86 B



Fig. 86 C

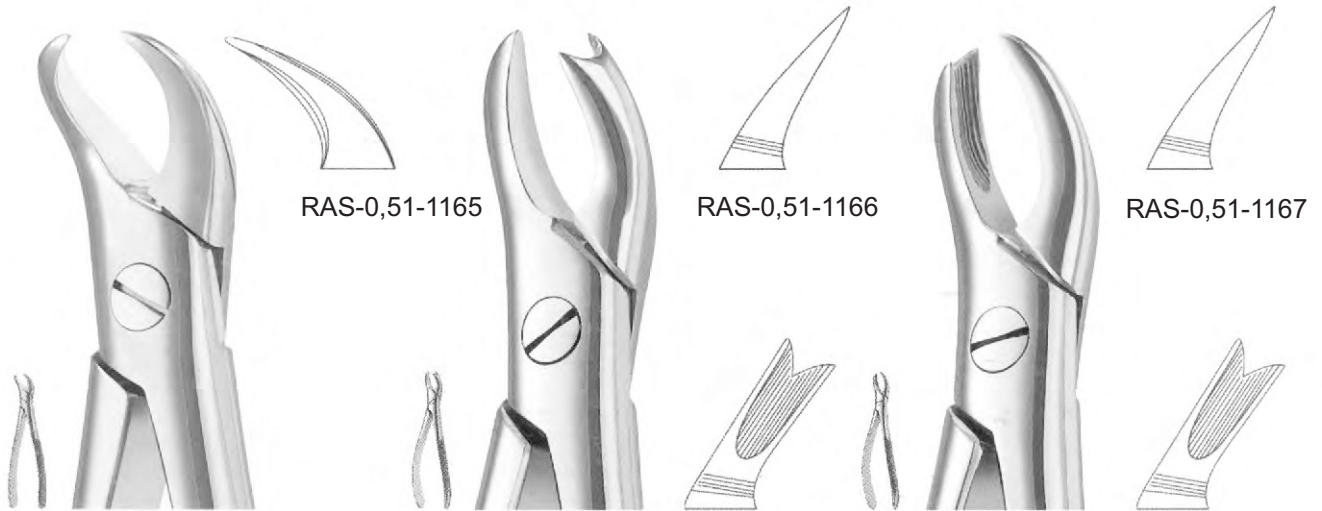

Fig. 87

Fig. 89

Fig. 90



Fig. 94

Fig. 95

WOOD
Fig. 99



RAS-0,51-1171

Fig. 113



OGDEN FELSCH
Fig. 121

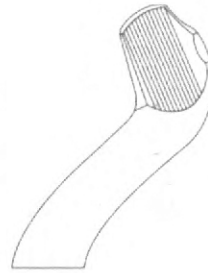

RAS-0,51-1172



RAS-0,51-1173

GUY
Fig. 136



RAS-0,51-1174

GUY
Fig. 137



Fig. 160

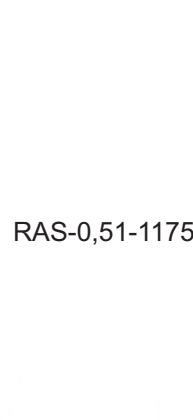

RAS-0,51-1175



RAS-0,51-1176

Fig. 162

EN	Extracting Forceps English Pattern
DE	Zange extrahieren englisches Muster
ES	Extracto de fórceps patrón inglés
FR	Forceps d'extraction modèle anglais
IT	Estrazione del forcipe modello inglese



RAS-0,51-1177
Fig. 233



RAS-0,51-1178



RAS-0,51-1179
Fig. 235



MEAD
Fig. MD 1

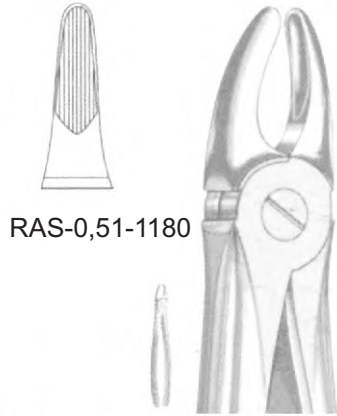

RAS-0,51-1180

MEAD
Fig. MD 2



RAS-0,51-1181

MEAD
Fig. MD 3



RAS-0,51-1182



RAS-0,51-1183

MEAD
Fig. MD 4

- EN Extracting Forceps English Pattern
- DE Zange extrahieren englisches Muster
- ES Extracto de fórceps patrón inglés
- FR Forceps d'extraction modèle anglais
- IT Estrazione del forcipe modello inglese

EXTRACTION



COHEN



RAS-0,51-1184

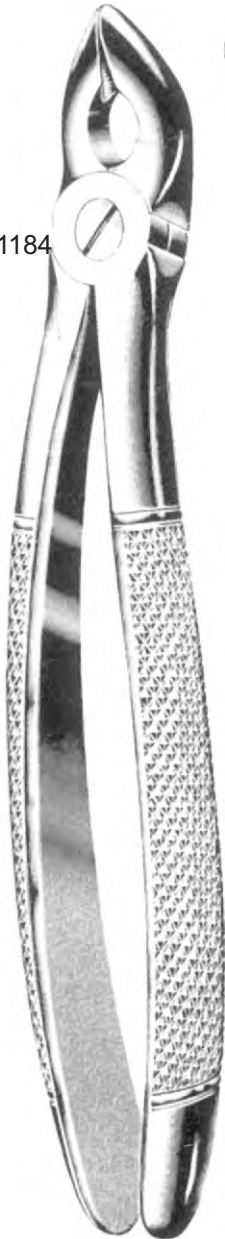

COHEN



RAS-0,51-1185



STIKSA



RAS-0,51-1186

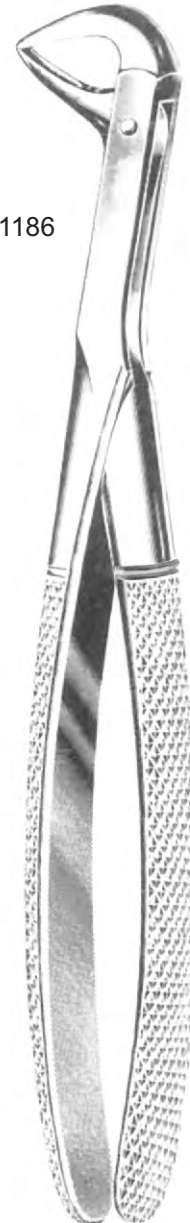

STIKSA



RAS-0,51-1187



Fig. 13 S



RAS-0,51-1188



Fig. 22 S



RAS-0,51-1189



Fig. 29 S



RAS-0,51-1190



Fig. 30 S



RAS-0,51-1191



Fig. 33 S



RAS-0,51-1192

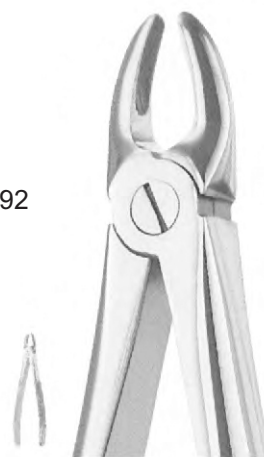

Fig. 37



RAS-0,51-1193

EN	Extracting Forceps English Pattern
DE	Zange extrahieren englisches Muster
ES	Extracto de fórceps patrón inglés
FR	Forceps d'extraction modèle anglais
IT	Estrazione del forcipe modello inglese



Fig. 38



Fig. 39



Fig. 39 A



Fig. 39 L

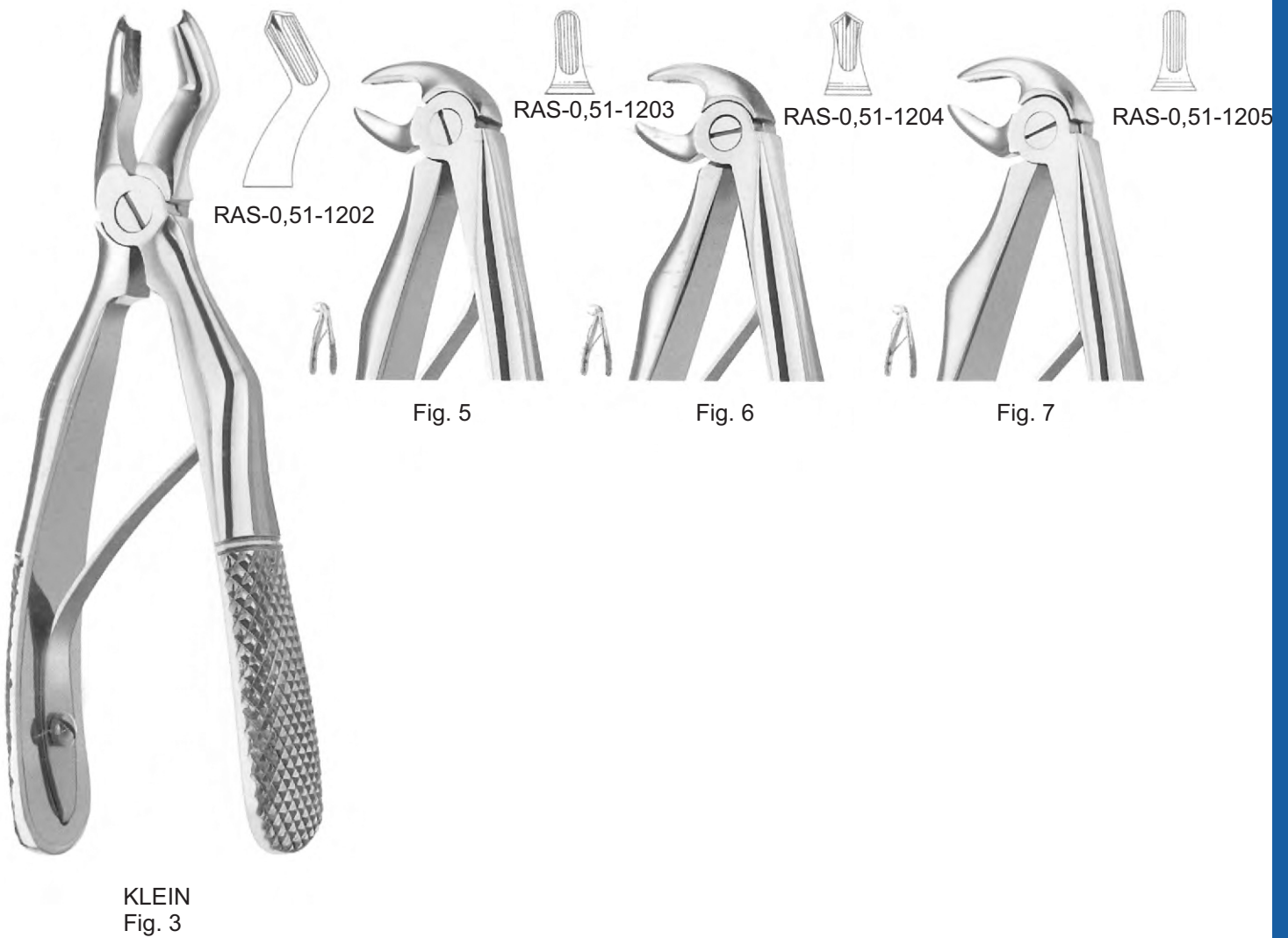

Fig. 39 R





EN Extracting Forceps Kids, English Pattern
DE Zange-Zangen extrahieren, englisches Muster
ES Extracción de fórceps para niños, patrón inglés
FR Forceps d'extraction enfants, modèle anglais
IT Estrazione di forcipi per bambini, modello inglese



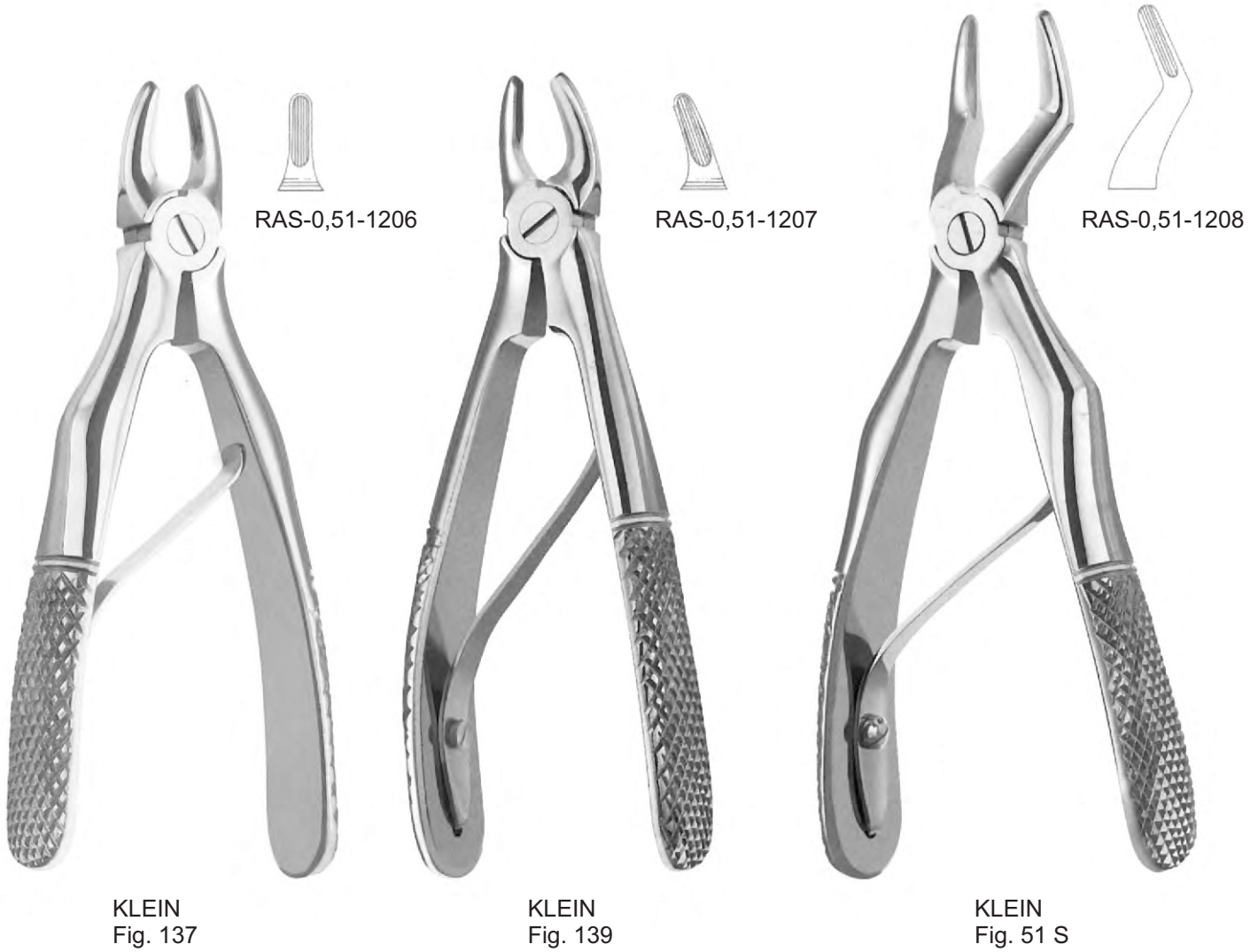

- EN** Root Elevators
- DE** Wurzelheber
- ES** Elevadores á racines
- FR** Botadores para raíces
- IT** Leve per radici

Page 40 to 54

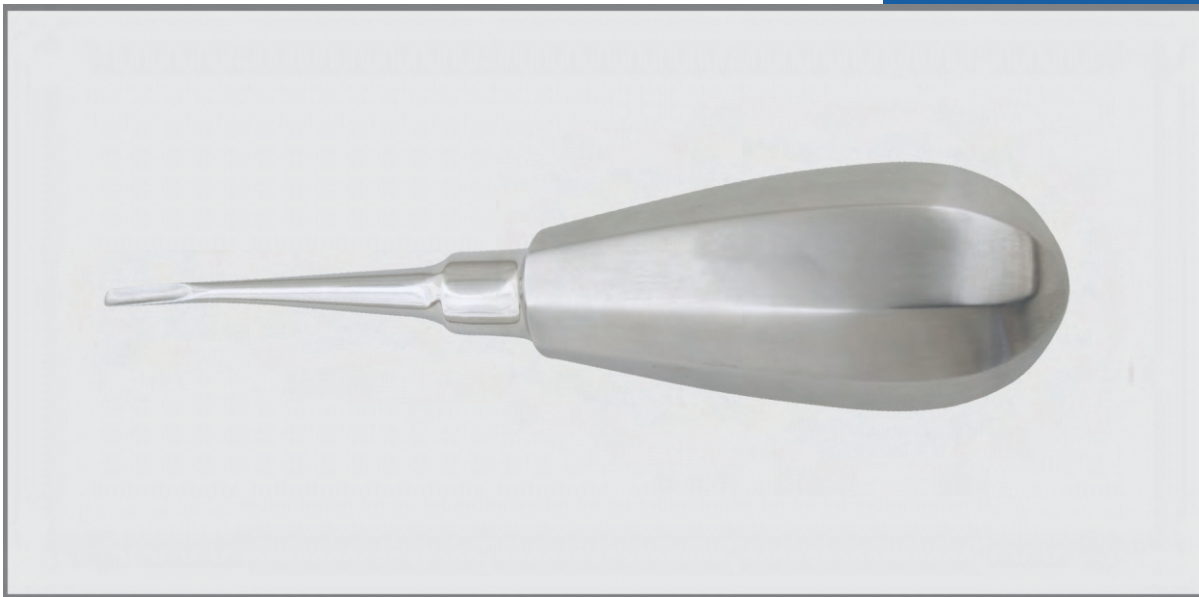

EN	Root Elevators
DE	Wurzelaufzüge
ES	Elevadores De Raíz
FR	Élévateurs De Racines
IT	Elevatori Di Root

ROOT ELEVATORS



	RAS-0,52-1251 Fig. 1 L	RAS-0,52-1252 Fig. 1 R	SALDIN RAS-0,52-1253 Fig. 2	SELDIN RAS-0,52-1254 Fig. 3	CRYER RAS-0,52-1255 Fig. 3 A
	SELDIN RAS-0,52-1256 Fig. 4 L	SELDIN RAS-0,52-1257 Fig. 4 R	CRANE (COGSWELL) RAS-0,52-1258 Fig. 6	JMLLER RAS-0,52-1259 Fig. 8	JMLLER RAS-0,52-1260 Fig. 9
	JMLLER (Apexo) RAS-0,52-1261 Fig. 10	JMLLER (Apexo) RAS-0,52-1262 Fig. 11	CRYER RAS-0,52-1263 Fig. 12		

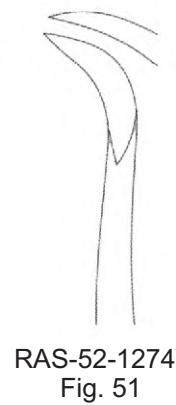
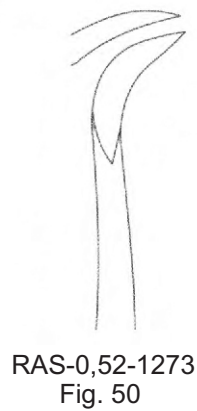
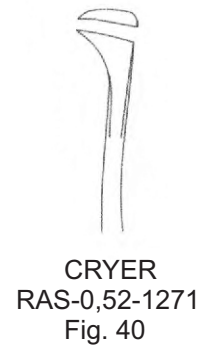
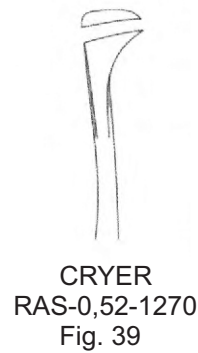
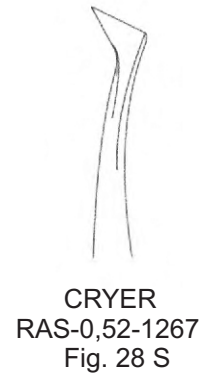
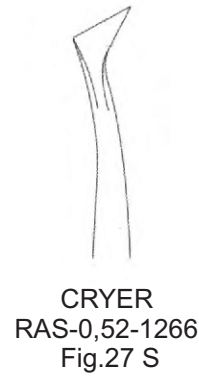
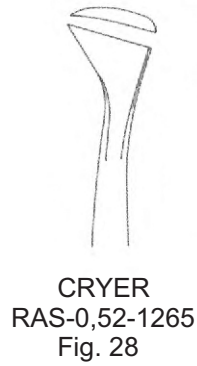
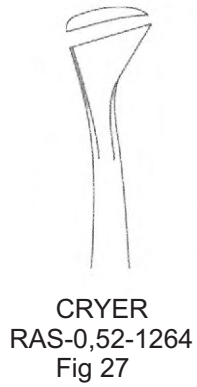

EN	Root Elevators
DE	Wurzelaufzüge
ES	Elevadores De Raíz
FR	Élévateurs De Racines
IT	Elevatori Di Root

ROOT ELEVATORS



APICAL (Apexo)
RAS-52-1275
Fig. 301

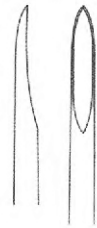

RAS-52-1276
Fig. 304

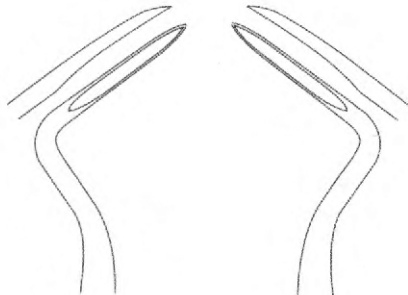

RAS-52-1277
Fig. 302

FLOHR
RAS-52-1278
Fig. 303



COLEMAN



RAS-52-1279
Fig. 1



RAS-52-1280
Fig. 2 L

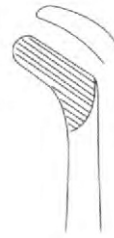

RAS-52-1281
Fig. 3 R



WARWICK JAMES
RAS-52-1282
16 cm/6 1/4"



RS-52-1283
Fig. 2 L



RAS-52-1284
Fig. 3 L



KOPP



RAS-52-1285
Fig. 1



RAS-52-1286
Fig. 2



RAS-52-1287
Fig. 3



RAS-52-1288
Fig. 4

EN	Root Elevators
DE	Wurzelaufzüge
ES	Elevadores De Raíz
FR	Élévateurs De Racines
IT	Elevatori Di Root



KOPP



RAS-52-1289
Fig. 1



RAS-52-1290
Fig. 2



RAS-52-1291
Fig. 3



RAS-52-1292
Fig. 4



FLOHR



RAS-52-1293
Fig. 1



RAS-52-1294
Fig. 2



RAS-52-1295
Fig. 3



FRIEDMAN
RAS-52-1296
Fig 1



RAS-52-1297
Fig. 2 L



RAS-52-1298
Fig. 3 R



HYLIN
RAS-52-1299
Fig. 1

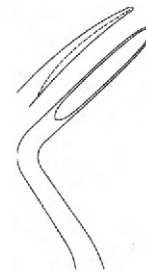

RAS-52-1301
Fig. 3 L

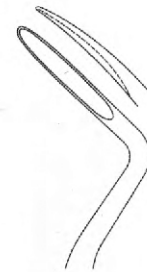

RAS-52-1302
Fig. 4 R

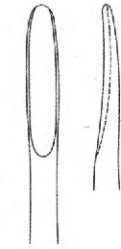

RAS-52-1300
Fig. 2

EN	Root Elevators
DE	Wurzelaufzüge
ES	Elevadores De Raíz
FR	Élévateurs De Racines
IT	Elevatori Di Root

ROOT ELEVATORS

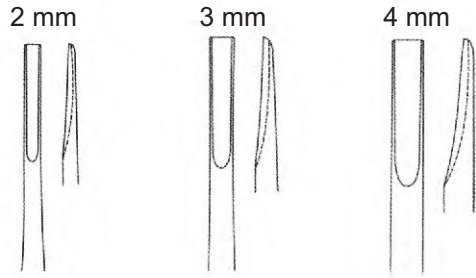

2 mm 3 mm 4 mm

BEIN

RAS-52-1303 RAS-52-1304 RAS-52-1305

Fig.0 Fig. 1 Fig. 2

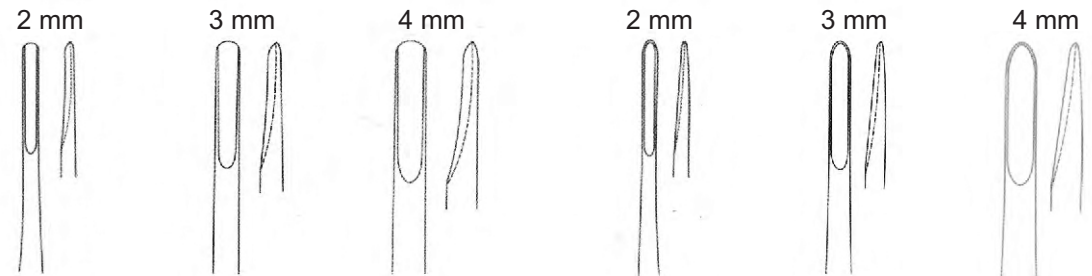

2 mm 3 mm 4 mm 2 mm 3 mm 4 mm

BEIN

RAS-52-1306 RAS-52-1307 RAS-52-1308 RAS-52-1309 RAS-52-1310 RAS-52-1311

Fig. 0 Fig. 1 Fig. 2 Fig. 0 Fig. 1 Fig. 2

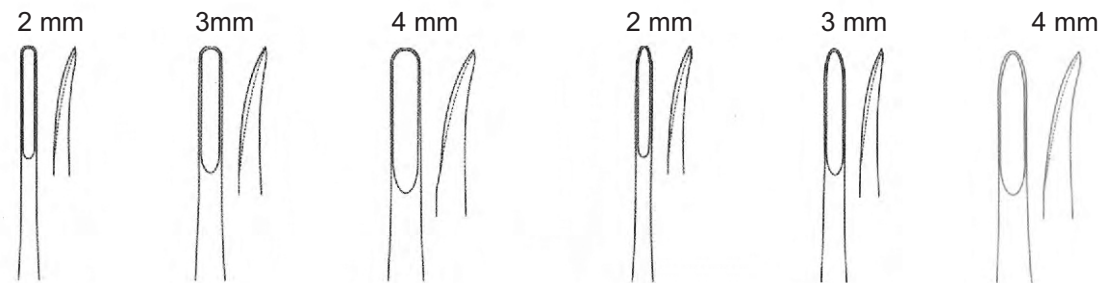

2 mm 3mm 4 mm 2 mm 3 mm 4 mm

BEIN

RAS-52-1312 RAS-52-1313 RAS-52-1314 RAS-52-1315 RAS-52-1316 RAS-52-1317

Fig. 0 A Fig. 1 A Fig.2 A Fig.0 A Fig. 1 A Fig. 2 A



COUPLAND

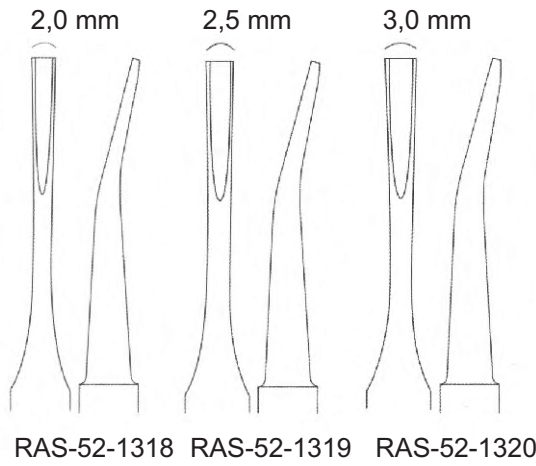

RAS-52-1318 RAS-52-1319 RAS-52-1320



LOOS

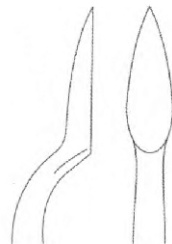
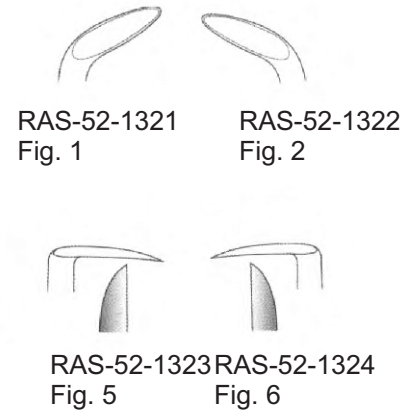

RAS-52-1325
Fig. 1

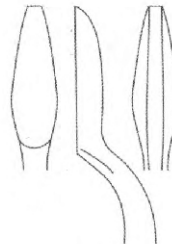

RAS-52-1326
Fig. 2

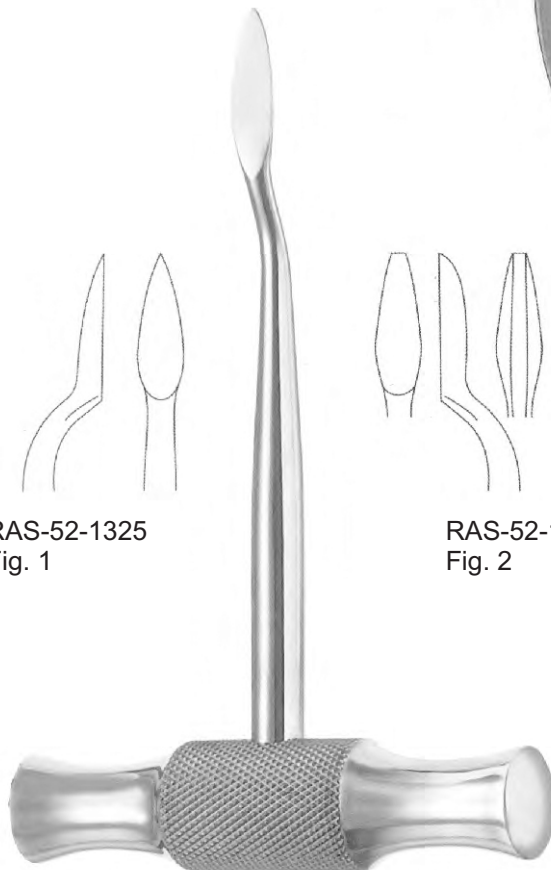

LECLUSE



BARRY
11 cm/4 1/4"



RAS-52-1327
Fig. 320 L



RAS-52-1328
Fig. 321 R



RAS-52-1329
Fig. 322



RAS-52-1330
Fig. 323

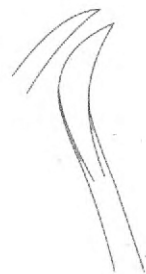

RAS-52-1331
Fig. 370



RAS-52-1332
Fig. 371



RAS-52-1333
Fig. 1 L



RAS-52-1334
Fig. 1 R



RAS-52-1335
Fig. 11 L



RAS-52-1336
Fig. 11 R



RAS-52-1337
Fig. 12 L



RAS-52-1338
Fig. 12 R



WINTER
11 cm/4 1/4"



RAS-52-1339
Fig. 13 L



RAS-52-1340
Fig. 13 R



RAS-52-1341
Fig. 14 L



RAS-52-1342
Fig. 14 R

EN	Root Elevators
DE	Wurzelaufzüge
ES	Elevadores De Raíz
FR	Élévateurs De Racines
IT	Elevatori Di Root

ROOT ELEVATORS



CHOMPRET



RAS-52-1343
Fig. 1



RAS-52-1344
Fig. 2



RAS-52-1345
Fig. 3



RAS-52-1346
Fig. 4



BERNARD



RAS-52-1347
Fig. 0

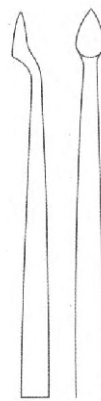

RAS-52-1348
Fig. 1

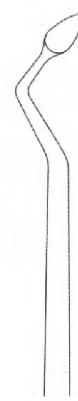

RAS-52-1349
Fig. 2

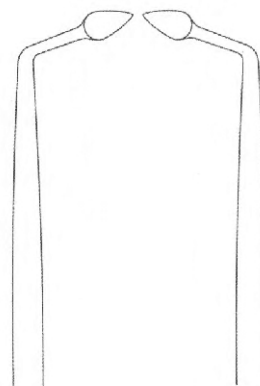

RAS-52-1350
Fig. 6

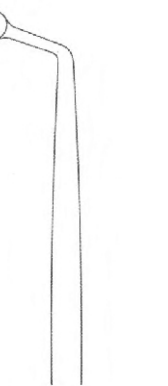

RAS-52-1351
Fig. 7



RAS-52-1352
Fig. 11



BERNARD
Handle # A

BERNARD
Handle # B



RAS-52-1353
Fig. 1



RAS-52-1354
Fig. 2



RAS-52-1355
Fig. 3



RAS-1356
Fig. 4



RAS-52-1357
Fig. 5



RS-52-1358
Fig. 10



RAS-52-1359
Fig. 8

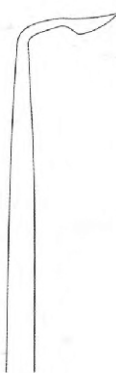

RAS-52-1360
Fig. 9



RAS-52-1361
Fig. 11



RAS-52-1362
Fig. 7

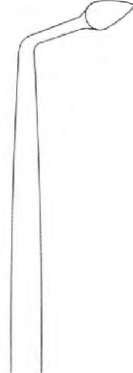

RAS-52-1363
Fig. 6

EN	Root Elevators
DE	Wurzelaufzüge
ES	Elevadores De Raíz
FR	Élévateurs De Racines
IT	Elevatori Di Root

ROOT ELEVATORS



HEIDBRINK



RAS-52-1366
Fig. 1



RAS-52-1367
Fig. 2



RAS-52-1368
Fig. 3



WEST (Apical)



RAS-52-1369
Fig. 1

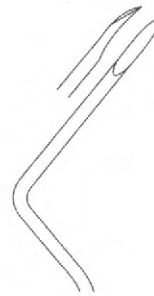

RAS-52-1370
Fig. 2 R

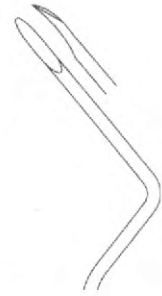

RAS-52-1371
Fig. 3 L



RATZOW

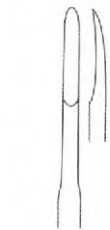

RAS-52-1372
Fig. 1



RAS-52-1373
Fig. 2



RAS-52-1374
Fig. 3



HEIDBRINK

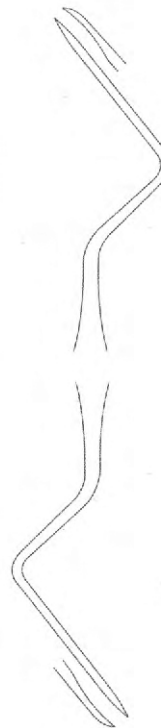

RAS-52-1375
Fig. 1

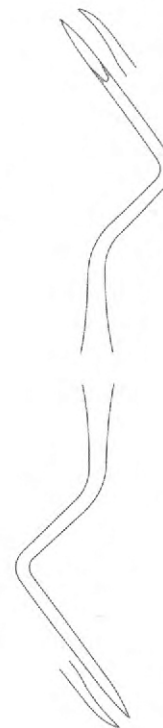

RAS-52-1376
Fig. 2

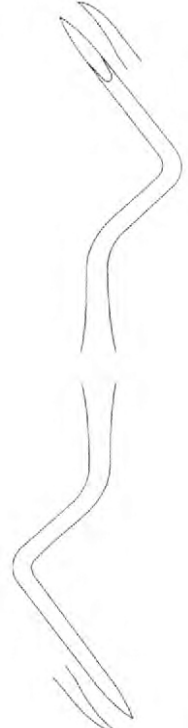

RAS-52-1377
Fig. 23

EN	Root Elevators
DE	Wurzelaufzüge
ES	Elevadores De Raíz
FR	Élévateurs De Racines
IT	Elevatori Di Root



VIGNAL



RAS-52-1378
Fig. 54



RAS-52-1379
Fig. 55

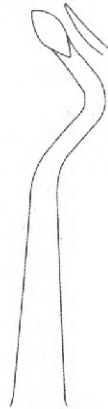

RAS-52-1380
Fig.56

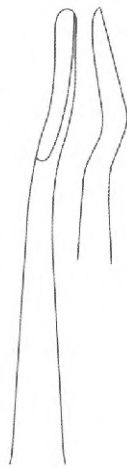

RAS-52-1381
Fig.57



RAS-52-1382
Fig. 69

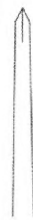
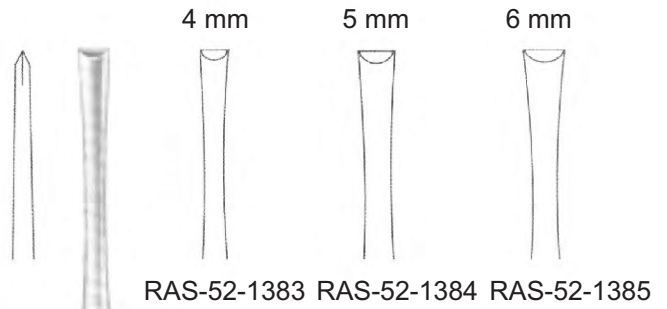

4 mm

5 mm

6 mm

RAS-52-1383 RAS-52-1384 RAS-52-1385



BARRY
21.5 cm/8 3/4"

- EN** Bone Files
- DE** Bone-Dateien
- ES** Archivos de huesos
- FR** Fichiers d'os
- IT** Bone Files

Page 55 to 56

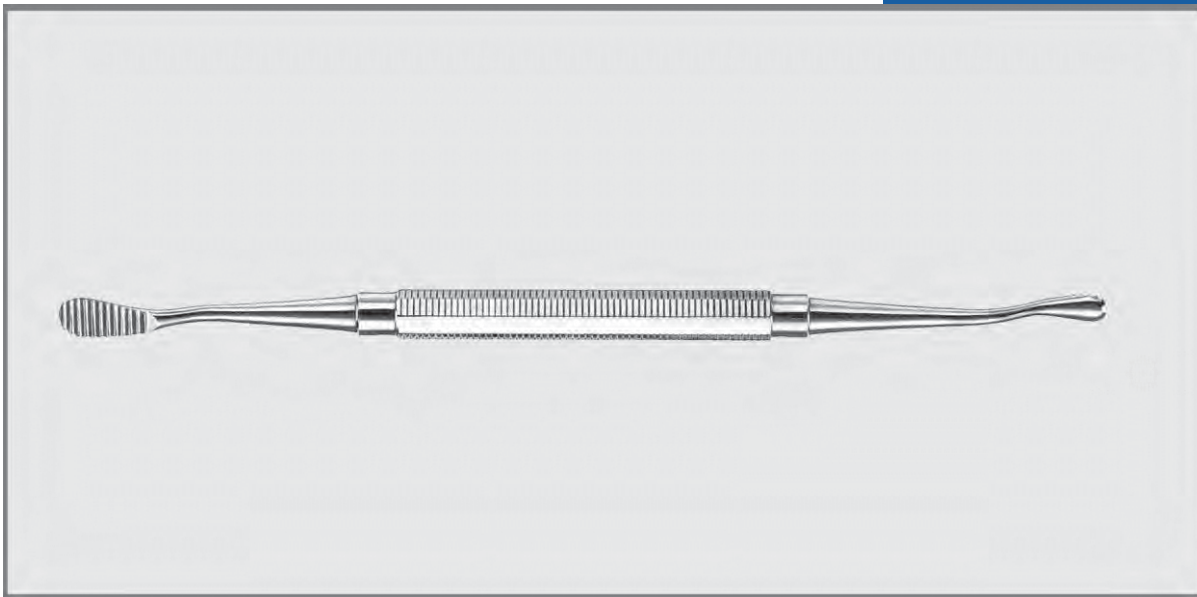

EN	Bone files
DE	Knochenfeilen
ES	Limes à os
FR	Lima para huesos
IT	Lima per ossa

BONE FILES

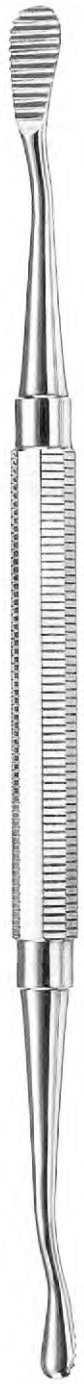

downwards cutting

JMLLER-COLBURN
18 cm/7"

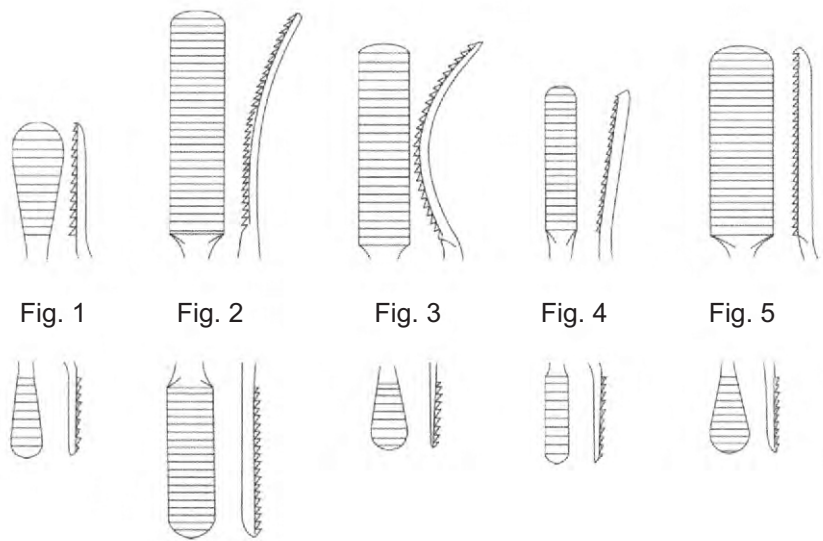

Fig. 1 Fig. 2 Fig. 3 Fig. 4 Fig. 5

RAS-53-1401 RAS-53-1402 RAS-53-1403 RAS-53-1404 RAS-53-1405

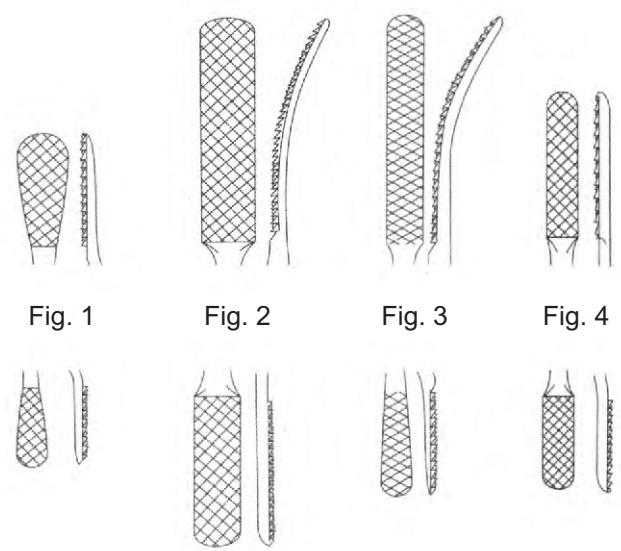

Fig. 1 Fig. 2 Fig. 3 Fig. 4

RAS-53-1406 RAS-53-1407 RAS-53-1408 RAS-53-1409

cross cut



JMLLER-COLBURN
18 cm/7"

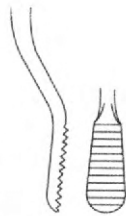

SELDIN
RAS-53-1410
18 cm/7"
Fig. 11

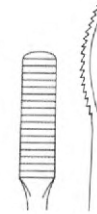

SELDIN
RAS-53-1411
18 cm/7"
Fig. 12

- EN** Dental Probes
- DE** Zahnsonden
- ES** Sondas dentales
- FR** Sondes dentaires
- IT** Sonde dentali

Page 57 to 58

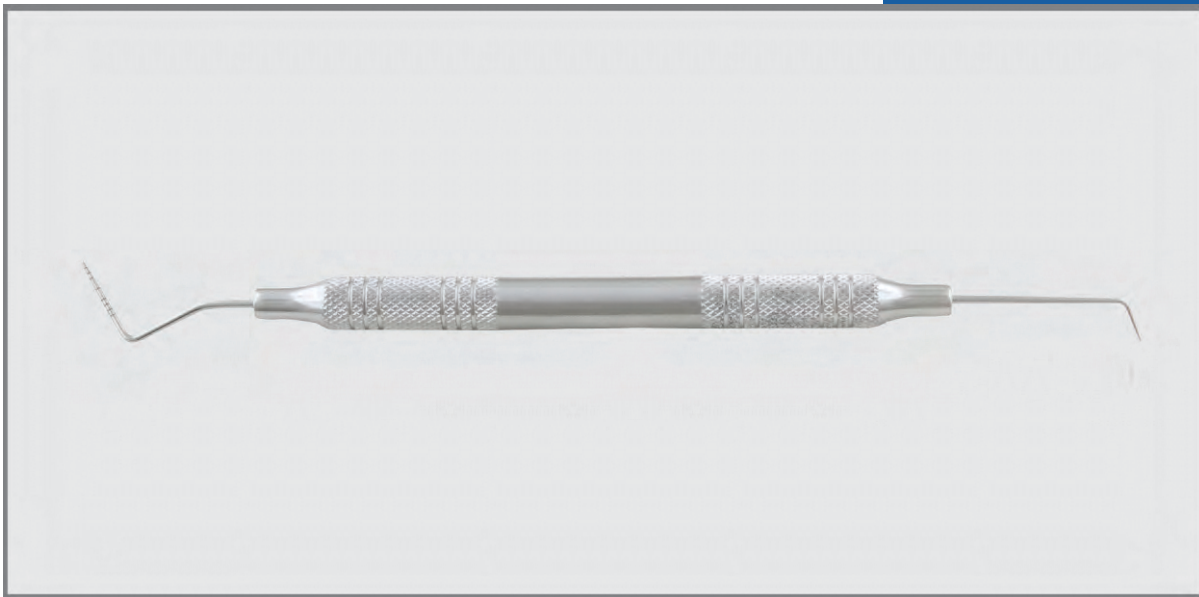

EN	Probes - Single Ended
DE	Sonden - Single Ended
ES	Sondas - terminación simple
FR	Sondes - Single Ended
IT	Sonde - Single Ended

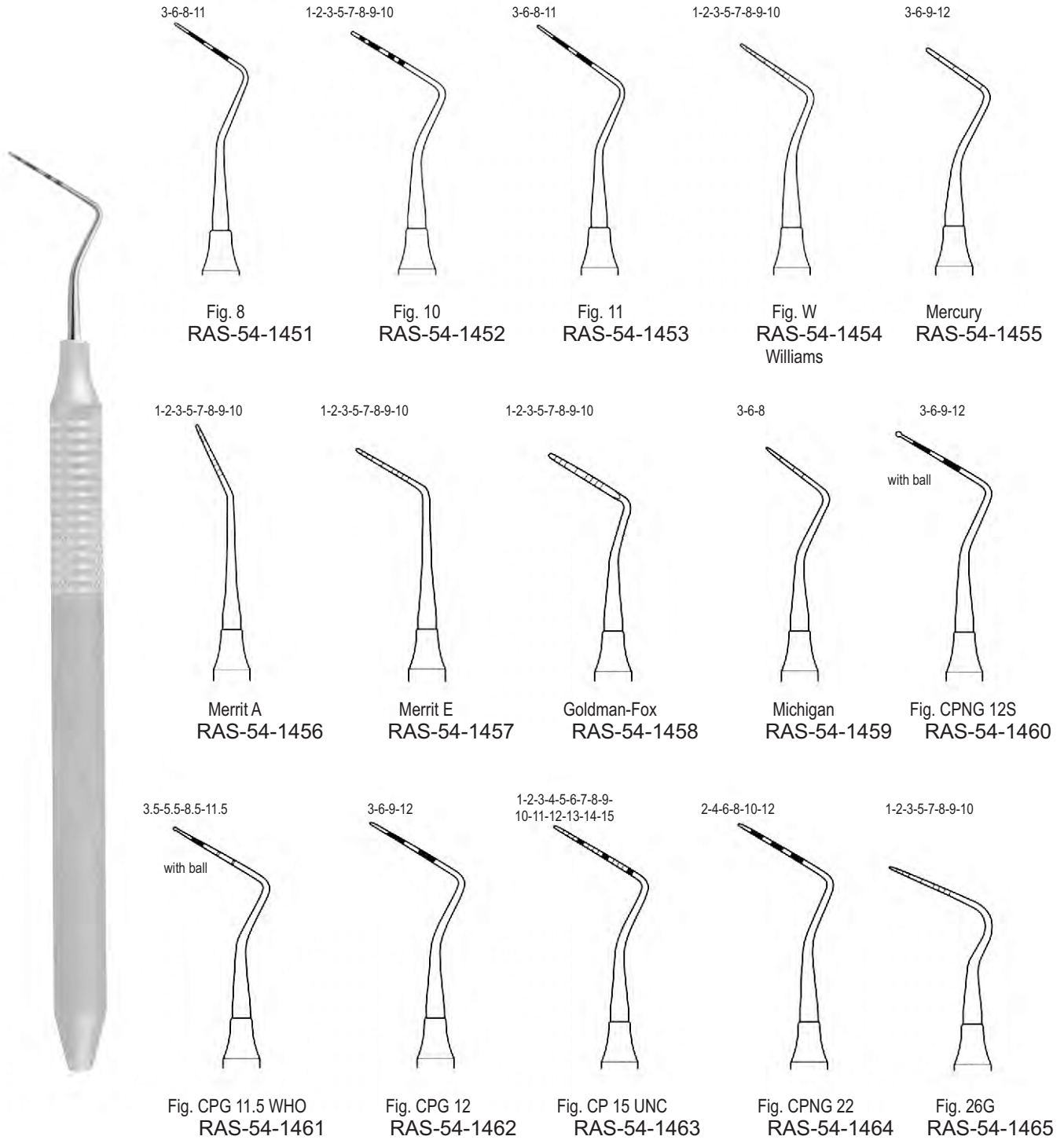

1-2-3-5-7-8-9-10
FLAT



Goldman-Fox
Williams
RAS-54-1466

3-6-9-12

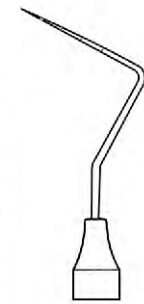

Fig. UT 3/4
Cattoni
RAS-54-1467



12-9-6-3

1-2-3-5-7-8-9-10
FLAT

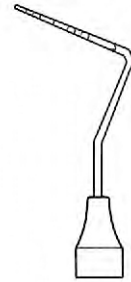
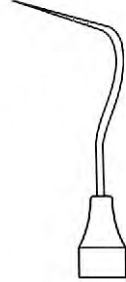

Fig. 3N
Nabers
RAS-54-1468



10-9-8-7-5-3-2-1

1-2-3-5-7-8-9-10



Williams DE
Offset
RAS-54-1469



10-9-8-7-5-3-2-1

3-6-9-12

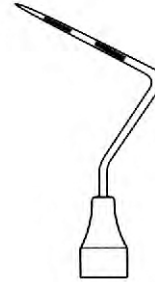
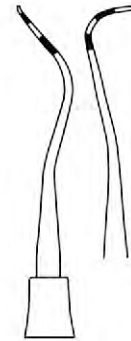

Fig. CP 12/Thin
Williams
RAS-54-1470



10-9-8-7-5-3-2-1



Nabers Furcation
probes graduated
working end
RAS-54-1471



- EN** Enamel Instruments
- DE** Emaille-Instrumente
- ES** Instrumentos de esmalte
- FR** Instruments d'email
- IT** Strumenti per smalto

Page 59 to 62

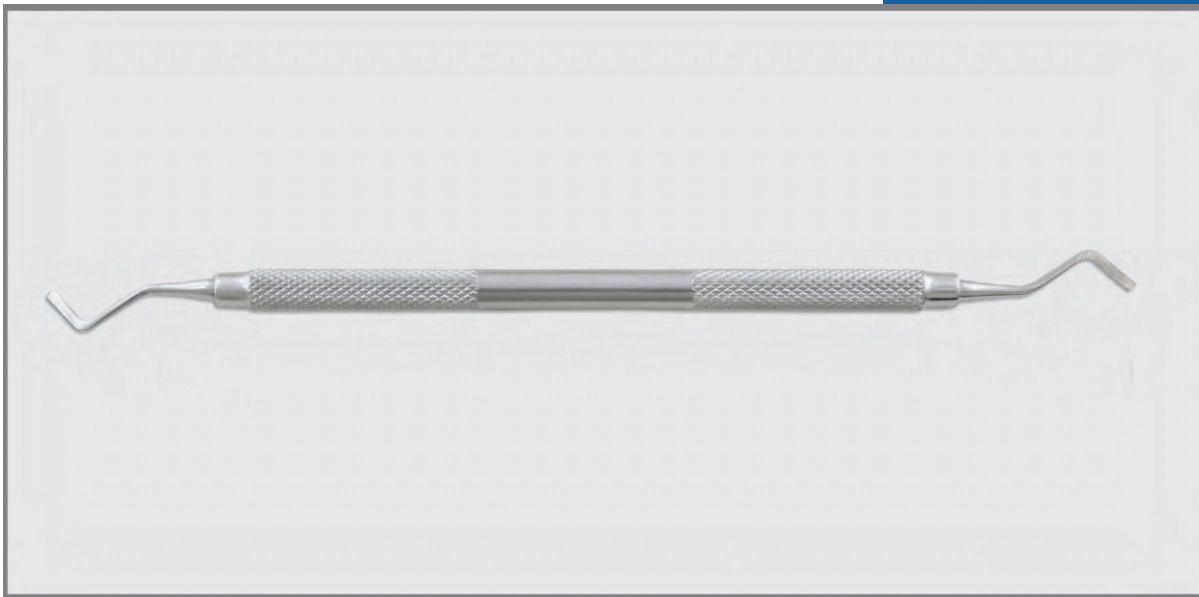

EN	Chisels
DE	Meißel
ES	Cinceles
FR	Ciseaux
IT	scalpelli



RAS-55-1501
Fig. 1
Black



RAS-55-1502
Fig. 2
Black



RAS-55-1503
Fig. 26
Black



RAS-55-1504
Fig. 27
Black



RAS-55-1505
Fig. 28
Black



RAS-55-1506
Fig. 29
Black





RAS-55-1507
Fig. 51/52
Black



RAS-55-1508
Fig. 53/54
Black



RAS-55-1509
Fig. 63/64
Black



RAS-55-1510
Fig. 65/66
Black



RAS-55-1511
Fig. 1/2
Wedelstaedt

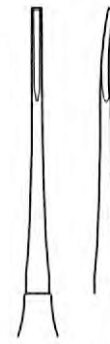

RAS-55-1512
Fig. 3/4
Wedelstaedt



RAS-55-1513
Fig. 5/6
Wedelstaedt

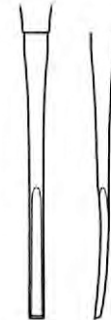
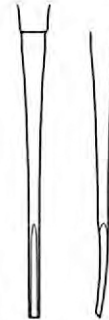

EN	Hatchets
DE	Beile
ES	Hatchets
FR	Hachettes
IT	Hatchets



RAS-55-1514
Fig. 8/9H



RAS-55-1515
Fig. 13/14



RAS-55-1516
Fig. 15/16



RAS-55-1517
Fig. 17/18



RAS-55-1518
Fig. 51/52



RAS-55-1519
Fig. 53/54



RAS-55-1520
Fig. 14/14
Off Angle



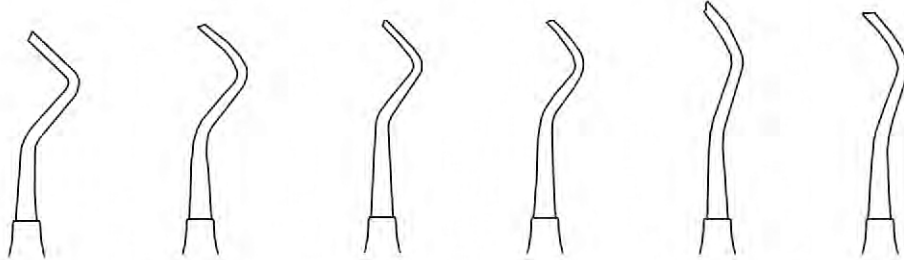

RAS-55-1521
Fig. 26
Distal

RAS-55-1522
Fig. 27
Mesial

RAS-55-1523
Fig. 28
Distal

RAS-55-1524
Fig. 29
Mesial

RAS-55-1525
Fig. 77/78
Distal

RAS-55-1526
Mesial
54-1142-00

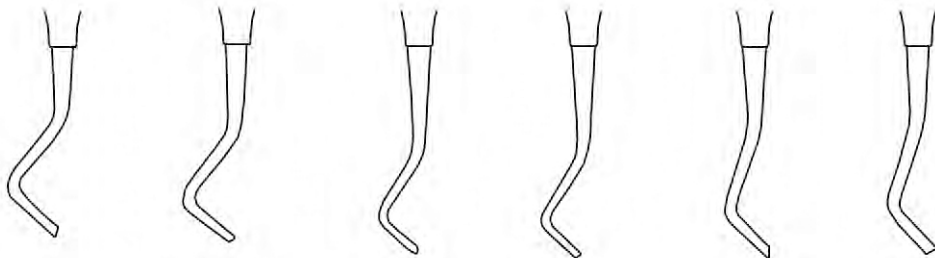

EN

Dental Scalers

DE

Zahnsteinentferner

ES

Escaladores dentales

FR

Scalers dentaires

IT

Scaler dentali

Page 63 to 78

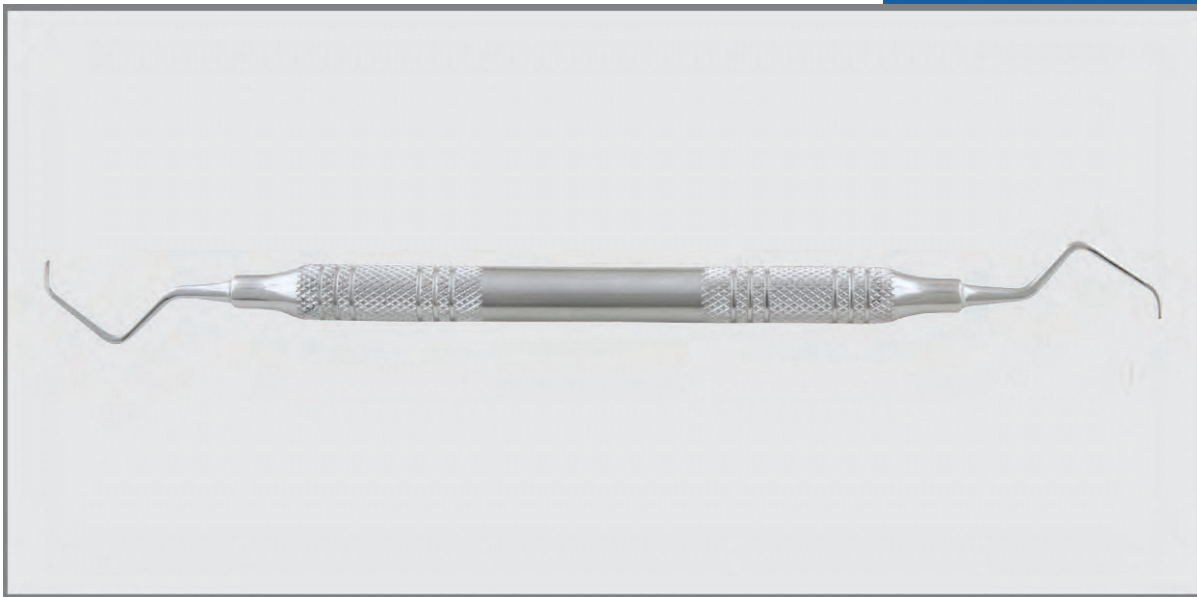

EN	Explorers - Single Ended
DE	Forscher - Single Ended
ES	Explorers - Single Finded
FR	Explorateurs - Single Ended
IT	Esploratori - Single Ended

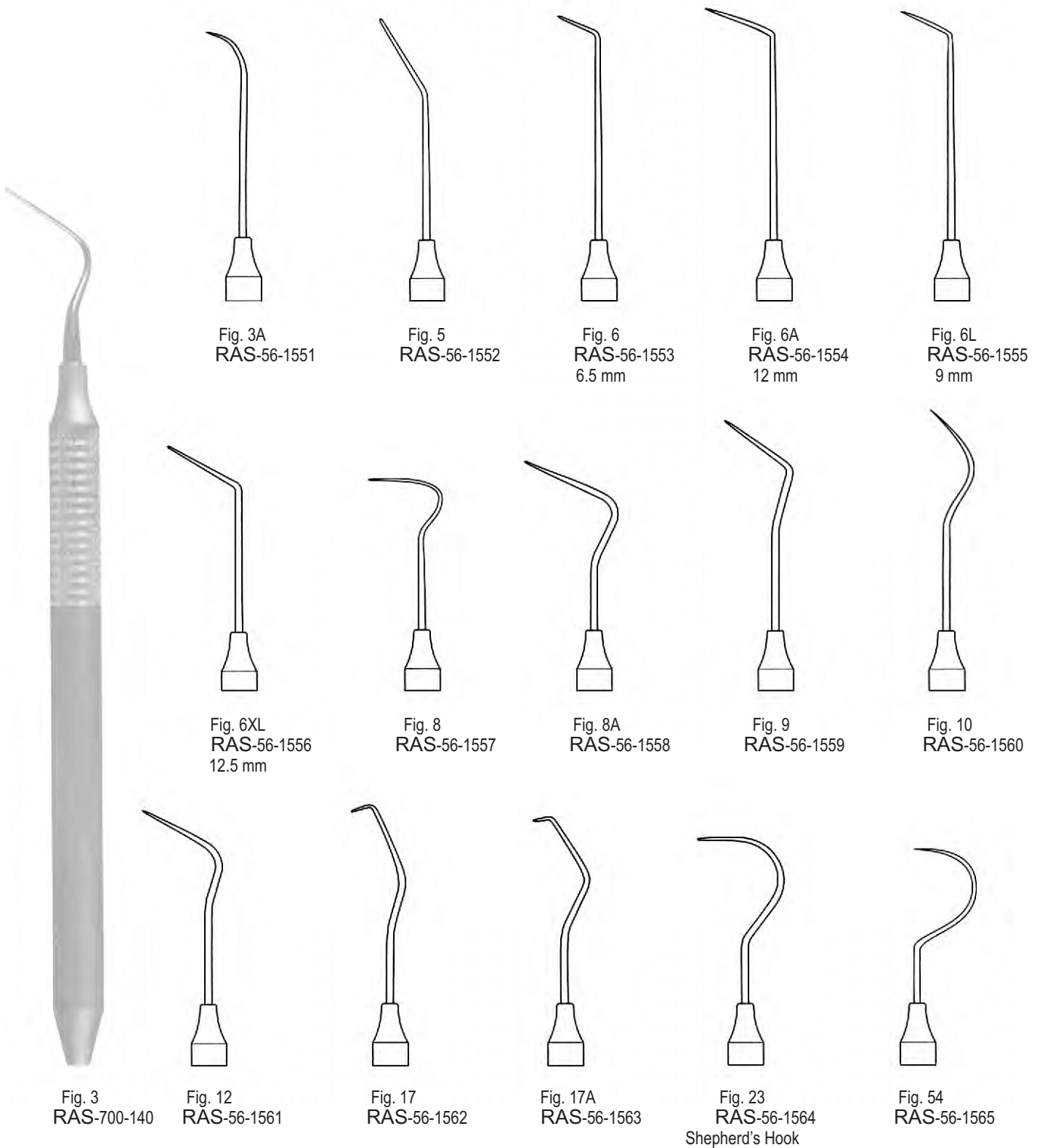



Fig. UT 1/2
56-1566



Fig. UT 2/2
RAS-56-1567

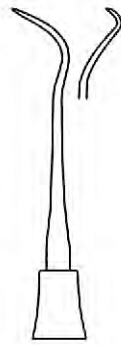

Fig. 3CH/3CH
RAS-56-1568

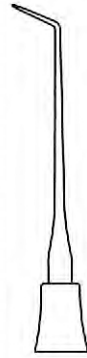

Fig. 6/3
RAS-56-1569



Fig. 16/3
RAS-56-1570



Fig. 2
RAS-56-1571

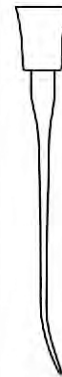
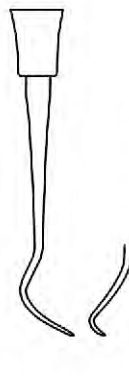
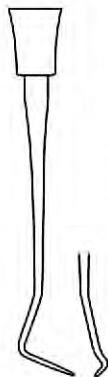

EN	Explorers - Double Ended
DE	Forscher - Doppelt beendigt
ES	Exploradores - Doble final
FR	Explorers - Double Ended
IT	Esploratori - Double Ended



Fig. 23/17
56-1572



Fig. 2A
RAS-56-1573



Fig. 3
RAS-56-1574



Fig. 1N
RAS-56-1575
Nabers

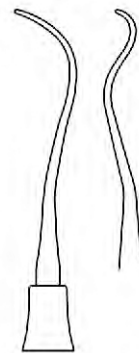

Fig. 2N
RAS-56-1576
Nabers

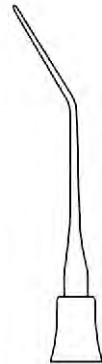

Fig. 5/6
RAS-56-1577

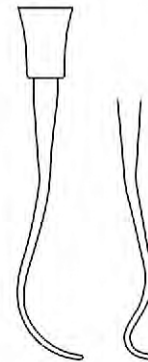
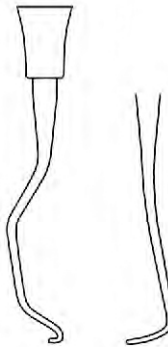
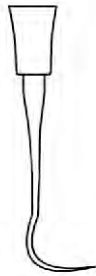



Fig. 16/23
RAS-56-1578



Fig. 6/23
RAS-56-1579

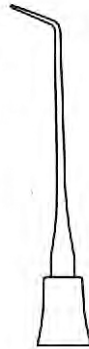

Fig. 6/17
RAS-56-1580



Fig. 23/17A
RAS-56-1581



Fig. 3/23
RAS-56-1582

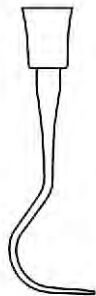

EN	Gracey Curettes
DE	Gracey Küretten
ES	Gracey Curettes
FR	Curettes Gracey
IT	Gracey Curettes



RAS-56-1583
Fig. 1/2



RAS-56-1584
Fig. 3/4



RAS-56-1585
Fig. 5/6



RAS-56-1586
Fig. 7/8





RAS-56-1587
Fig. 9/10



RAS-56-1588
Fig. 11/12



RAS-56-1589
Fig. 13/14



RAS-56-1590
Fig. 15/16

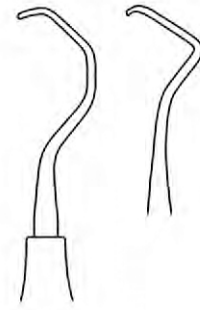

RAS-56-1591
Fig. 17/18

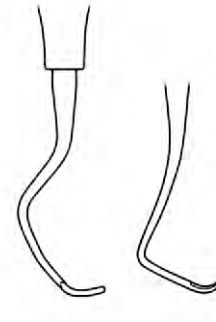

EN	Universal Curettes
DE	Universalküretten
ES	Curetas universales
FR	Curettes universelles
IT	Curette universali



Langer
RAS-56-1592
Fig. 1/2

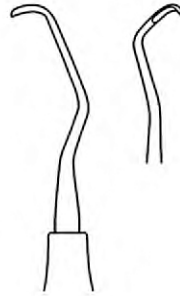

Langer
RAS-56-1593
Fig. 3/4



Langer
RAS-56-1594
Fig. 5/6



Langer
RAS-56-1595
Fig. 17/18



Universal curettes are designed for easy adaptation on all tooth surfaces (thus the name "universal").

The blade of a universal curette has a round toe and back, and two cutting edges for scaling, making it an efficient design for scaling the entire mouth.

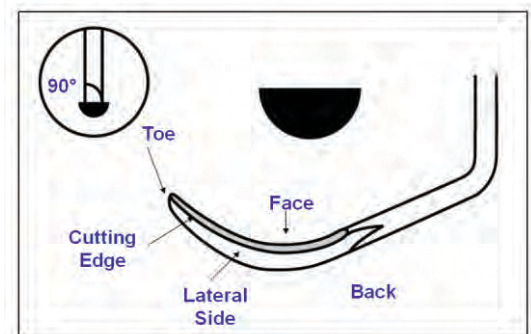



Columbia
RAS-56-1596
Fig. 13/14



Columbia
RAS-56-1597
Fig. 2R/2L



Columbia
RAS-56-1598
Fig. 4R/4L



RAS-56-1599
Fig. Gx4



Barnhart
RAS-56-1600
Fig. 1/2



Barnhart
RAS-56-1601
Fig. 5/6



EN	Universal Curettes
DE	Universalküretten
ES	Curetas universales
FR	Curettes universelles
IT	Curette universali

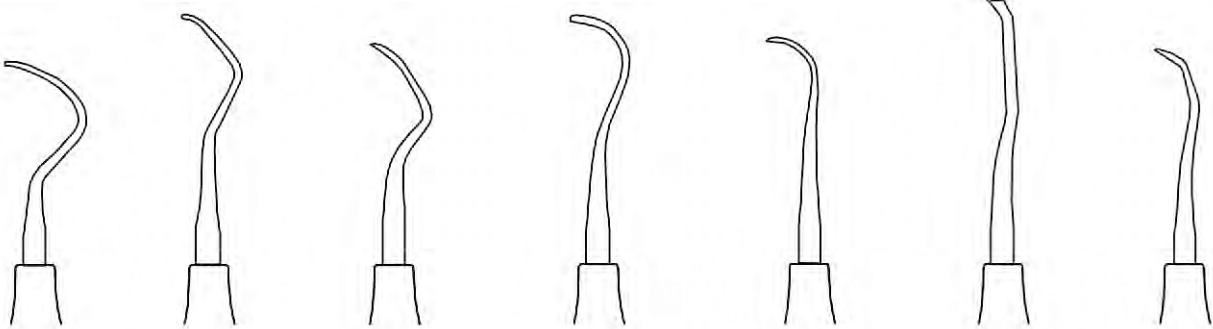

RAS-56-1602
Fig. Me1

RAS-56-1603
Rule [23-24]
Fig. 3/4

RAS-56-1604
Fig. IU 13/14
Indiana University

RAS-56-1605
Fig. IU 17/18
Indiana University

RAS-56-1606
Fig. 7/8
Younger-Good

RAS-56-1607
Fig. 1/2
Bunting

RAS-56-1608
Fig. 5/6
Bunting

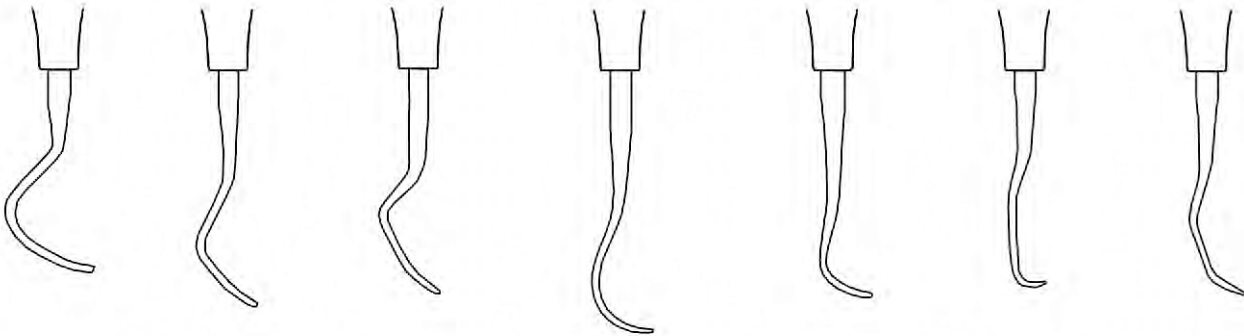



RAS-56-1609
Fig. 1
Furcation curette



RAS-56-1610
Fig. 2
Furcation curette

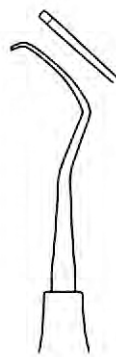

RAS-56-1611
Fig. 3
Furcation curette

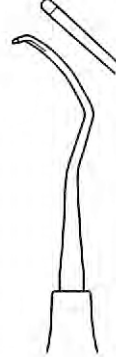

RAS-56-1612
Fig. 4
Furcation curette



RAS-56-1613
Fig. 5
Furcation curette



RAS-56-1614
Fig. 1/2
Prichard

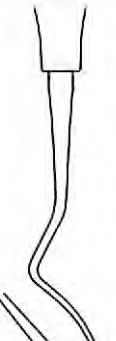
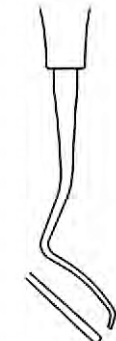

EN	Scalers / Curettes
DE	Scaler / Küretten
ES	Scalers / Curettes
FR	Scalers / Curettes
IT	Scaler / Curette

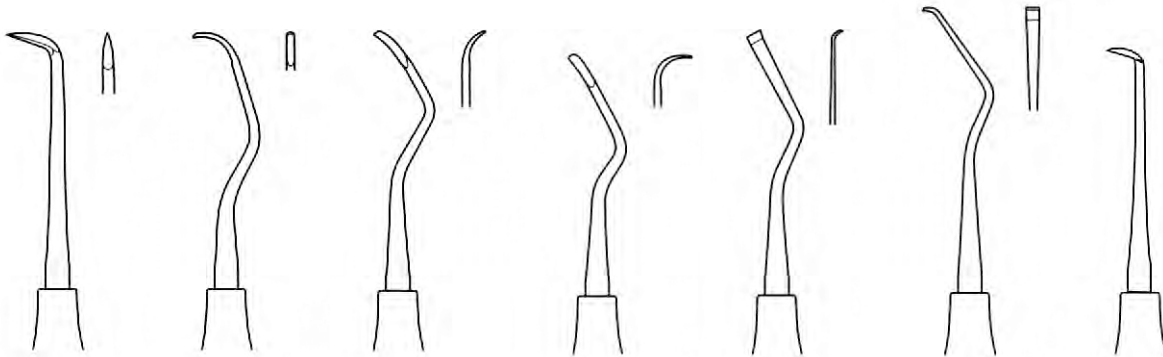

RAS-56-1615 Goldman-Fox Fig. 1	RAS-56-1616 Goldman-Fox Fig. 2	RAS-56-1617 Goldman-Fox Fig. 3	RAS-56-1618 Goldman-Fox Fig. 4	RAS-56-1619 Goldman-Fox Fig. 5	RAS-56-1620 Goldman-Fox Fig. 6	RAS-56-1621 Goldman-Fox Fig. 21
---	---	---	---	---	---	--

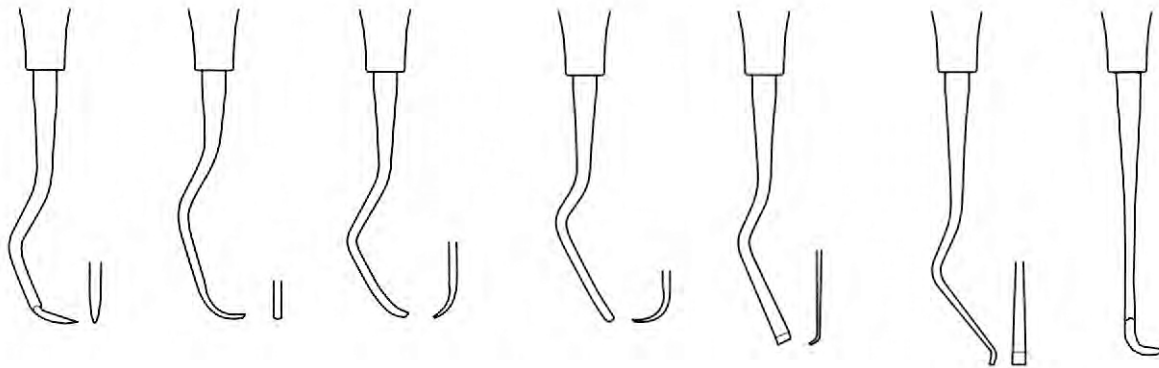

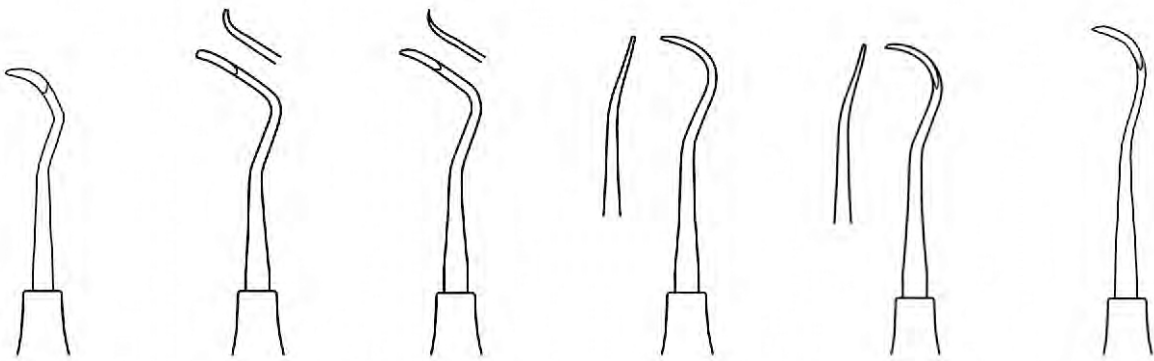

RAS-56-1622
McCall
Fig. 11/12

RAS-56-1623
McCall
Fig. 13S/14S

RAS-56-1624
McCall
Fig. 13SM/14

RAS-56-1625
McCall
Fig. 17/18

RAS-56-1626
McCall
Fig. 17S/18S

RAS-56-1627
McCall
Fig. 19/20

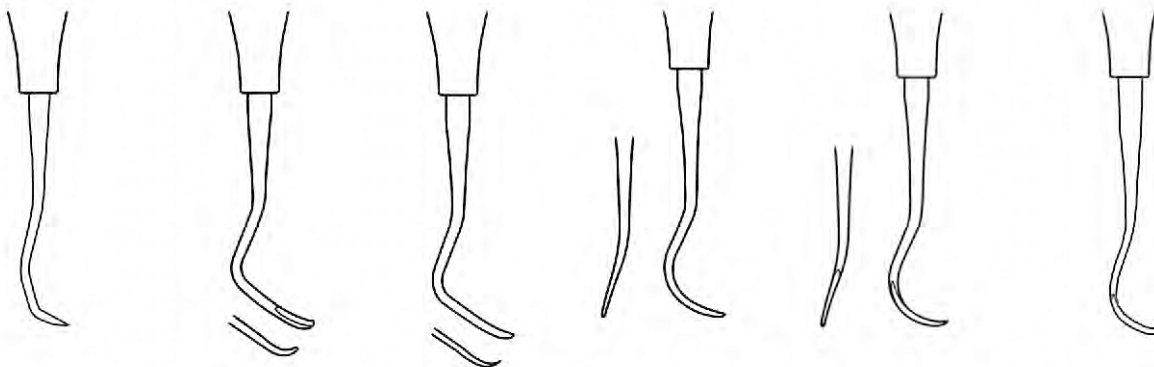

EN	Sickle Scaler
DE	Sichel-Scaler
ES	Escalador de hoz
FR	Scaler de faucille
IT	Sickle Scaler

DENTAL SCALERS

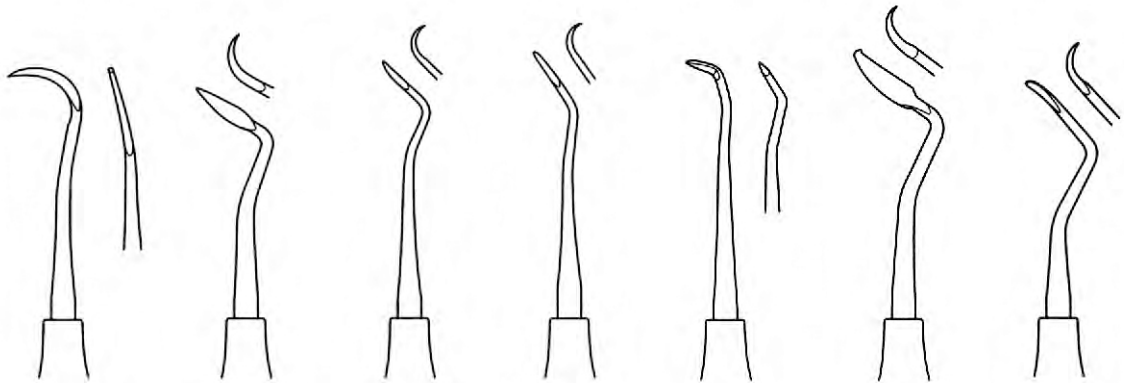

RAS-56-1628
Hygienist
Fig. H6/H7

RAS-56-1629
Fig. 204

RAS-56-1630
Fig. 204 S

RAS-56-1631
Fig. 204 SD

RAS-56-1632
Zürich

RAS-56-1633
Fig. CC 6

RAS-56-1634
Fig. M 23

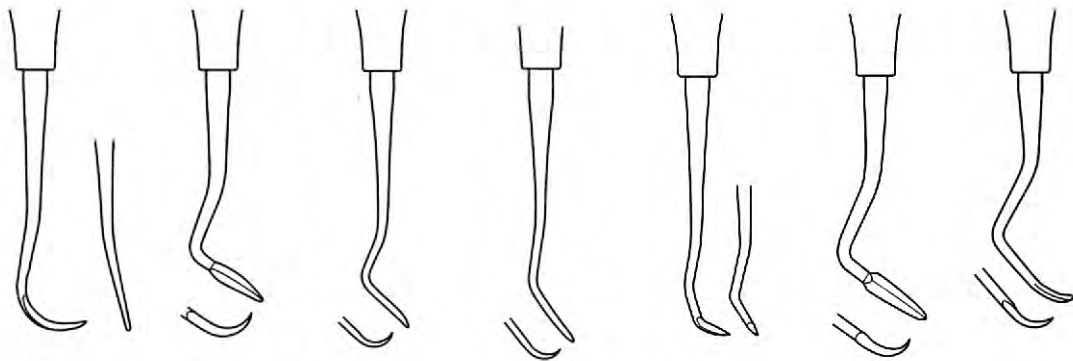

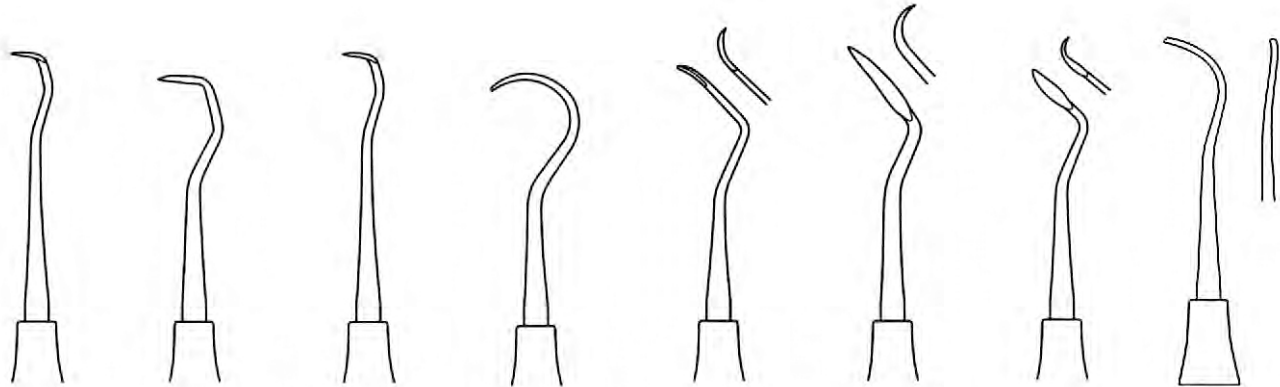

RAS-56-1635 Hygienist-Towner Fig. H5/33	RAS-56-1636 Towner Fig. U15/30	RAS-56-1637 Towner Fig. U15/33	RAS-56-1638 Hygienist-Towner Fig. H5/U15	RAS-56-1639 Fig. U 135	RAS-56-1640 Fig. CI 2/3	RAS-56-1641 Taylor Fig. T2/T3	RAS-56-1642 Younger-Good Fig. 33/34
---	--------------------------------------	--------------------------------------	--	---------------------------	----------------------------	-------------------------------------	---

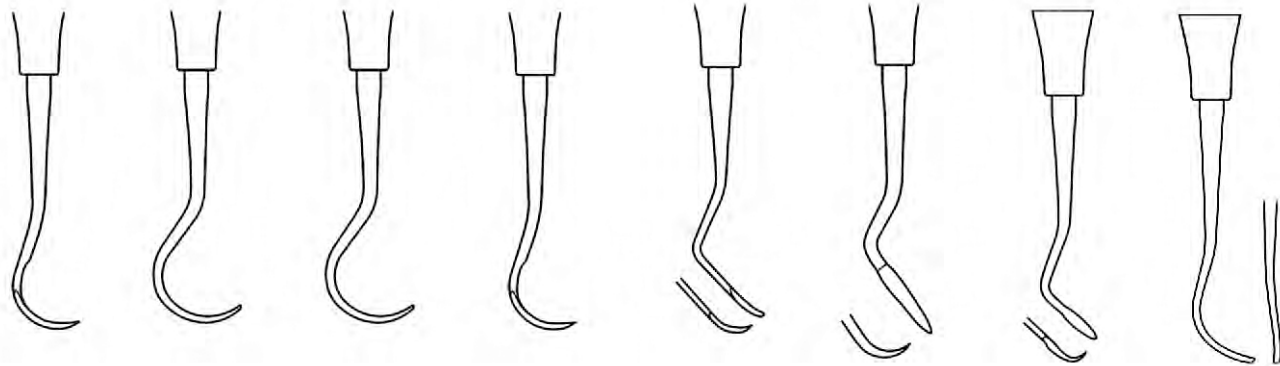

EN	Sickle Scaler
DE	Sichel-Scaler
ES	Escalador de hoz
FR	Scaler de faucille
IT	Sickle Scaler

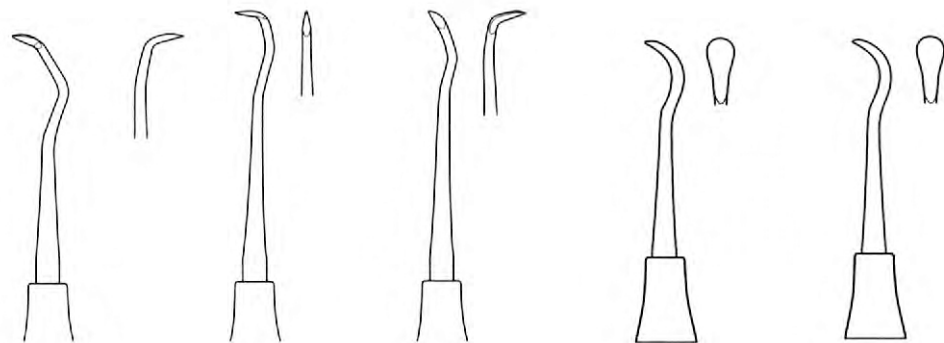

RAS-56-1643
Jacquette
Fig. 31/32

RAS-56-1644
Jacquette
Fig. 30/33

RAS-56-1645
Jacquette
Fig. 34/35

RAS-56-1646
Cumine
Fig. 33

RAS-56-1647
Mitchell
Fig. 34

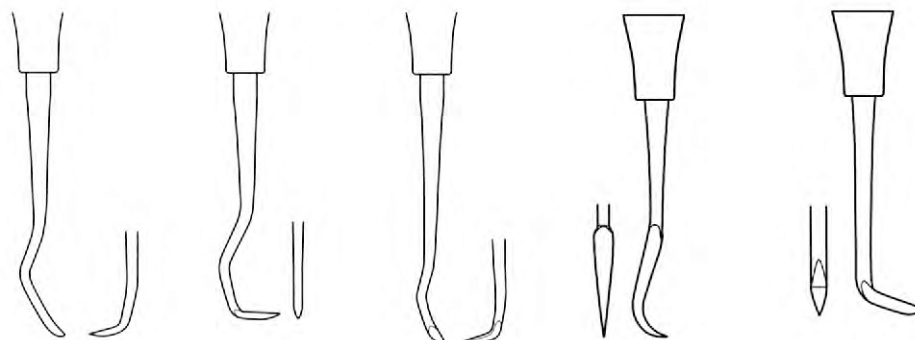



RAS-56-1648
Jacquette
Fig. 33

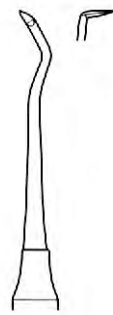

RAS-56-1649
Jacquette
Fig. 34

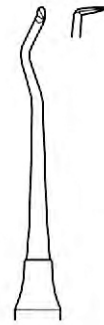

RAS-56-1650
Jacquette
Fig. 35

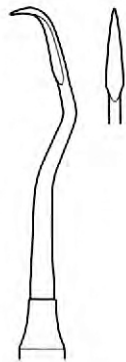

RAS-56-1651
Ward-Kirkland
Fig. 1



RAS-56-1652
Crane-Kaplan
Fig. 2

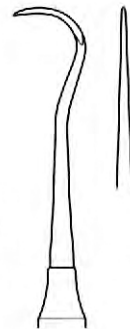

RAS-56-1653
Mercitan
Fig. Sh5

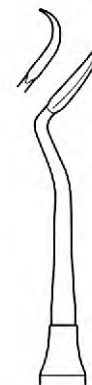

RAS-56-1654
Crane-Kaplan
Fig. 3



RAS-56-1655
White
Fig. 12B

- EN** Bone Currettes
- DE** Knochenküretten
- ES** Curetas de hueso
- FR** Curettes osseuses
- IT** Curette d'ossa

Page 79 to 84

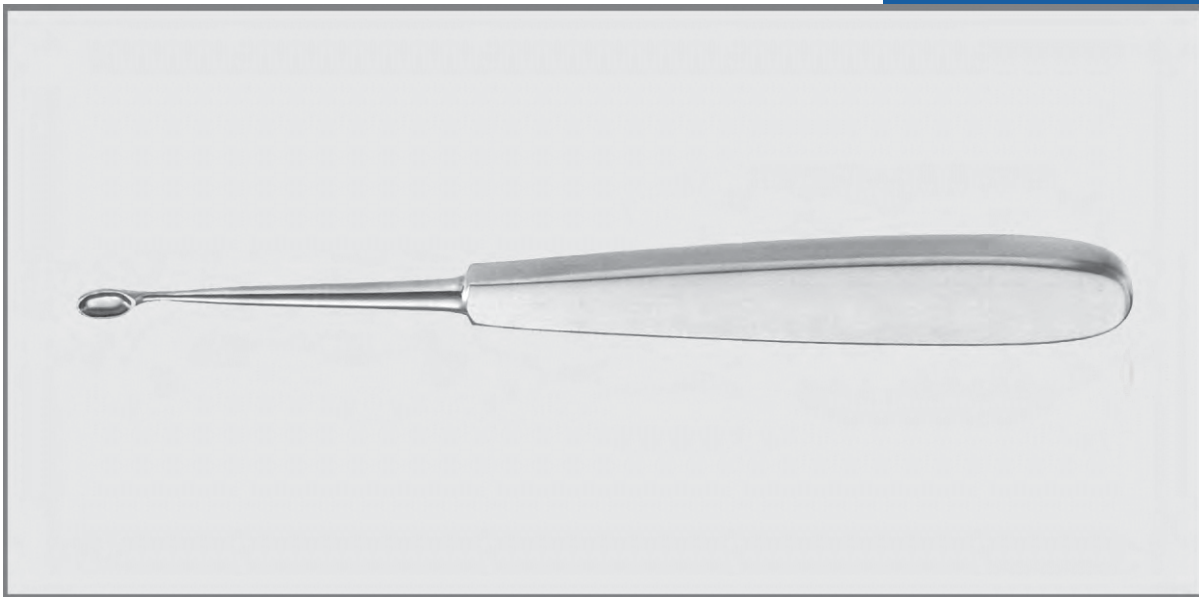

EN	Bone Curettes
DE	Scharf Löffel
ES	Curettes á os
FR	Cucharillas cortantes
IT	Curette taglienti

RAS-0,57-1701 RAS-0,57-1703
 RAS-0,57-1702 RAS-0,57-1704



WILLIGER

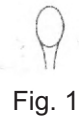
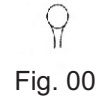

Fig. 00	RAS-0,57-1705	RAS-0,57-1709	RAS-0,57-1713	RAS-0,57-1717
Fig. 0	RAS-0,57-1706	RAS-0,57-1710	RAS-0,57-1714	RAS-0,57-1718
Fig. 1	RAS-0,57-1707	RAS-0,57-1711	RAS-0,57-1715	RAS-0,57-1719
Fig. 2	RAS-0,57-1708	RAS-0,57-1712	RAS-0,57-1716	RAS-0,57-1720



Mod. USA

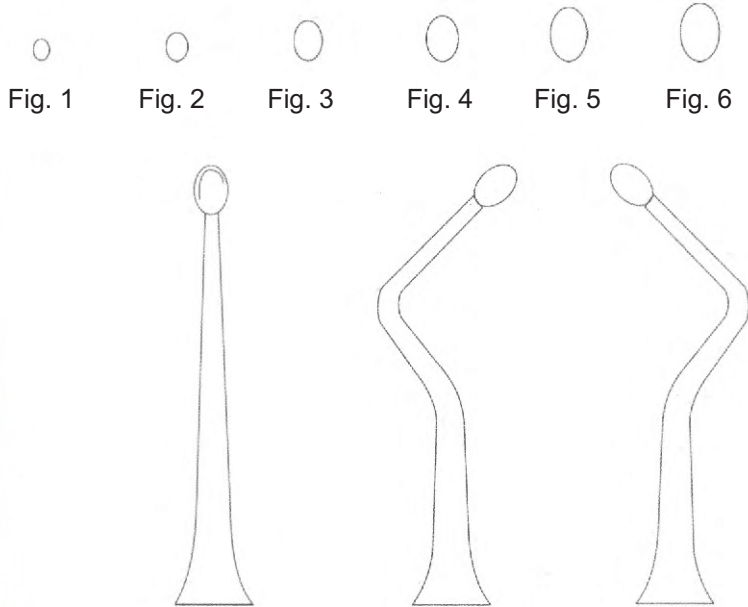

Fig. 1	RAS-0,57-1721	RAS-0,57-1727	RAS-0,57-1733
Fig. 2	RAS-0,57-1722	RAS-0,57-1728	RAS-0,57-1734
Fig. 3	RAS-0,57-1723	RAS-0,57-1729	RAS-0,57-1735
Fig. 4	RAS-0,57-1724	RAS-0,57-1730	RAS-0,57-1736
Fig. 5	RAS-0,57-1725	RAS-0,57-1731	RAS-0,57-1737
Fig. 6	RAS-0,57-1726	RAS-0,57-1732	RAS-0,57-1738

R

L



CHOMPRET
RAS-0,57-1739

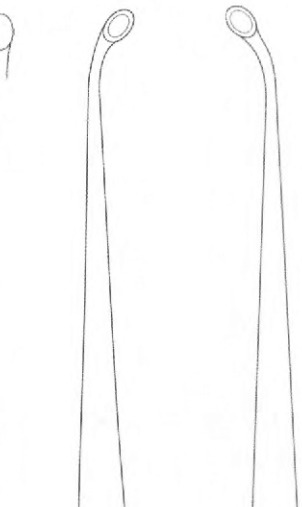

RAS-0,57-1740 R
RAS-0,57-1741 L

EN	Bone Currettes
DE	Scharf Löffel
ES	Curettes á os
FR	Cucharillas cortantes
IT	Curette taglienti

BONE CURETTES

RAS-0,57-1748- RAS-0,57-1750R-
RAS-0,57-1749 RAS-0,57-1751R



RAS-0,57-1742
Fig. 00/00

RAS-0,57-1743
Fig. 0/0

RAS-0,57-1744
Fig. 1/1



RAS-0,57-1745
Fig. 00/00

RAS-0,57-1746
Fig. 0/0

RAS-0,57-1747
Fig. 1/1



HEJMNGWAY
18 CM/7"

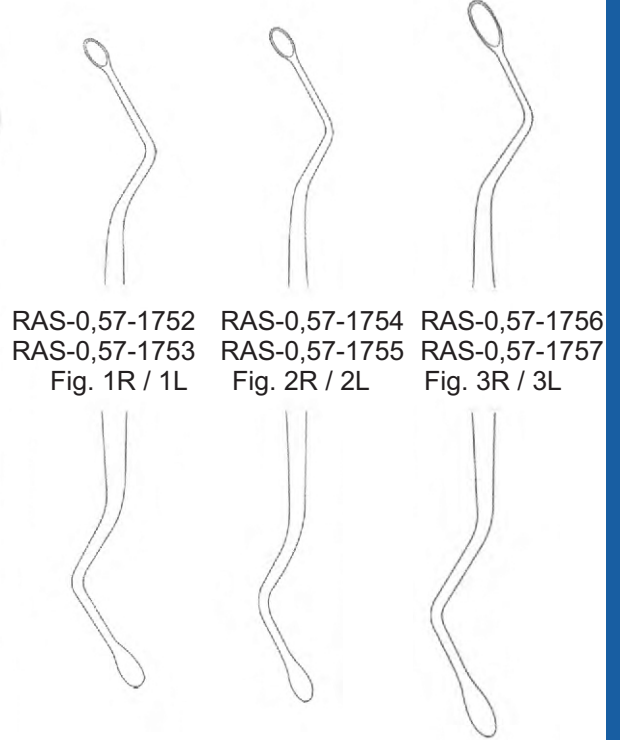

RAS-0,57-1752
RAS-0,57-1753
Fig. 1R / 1L

RAS-0,57-1754
RAS-0,57-1755
Fig. 2R / 2L

RAS-0,57-1756
RAS-0,57-1757
Fig. 3R / 3L

WILLGER

MARTINI



5,5 Ø9,5
mm mm

HEJMNGWAY
17 cm/6 ¾"

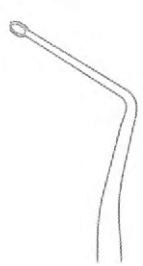

Fig. 0 / 0



RAS-0,57-1758



Fig. 1 / 1

RAS-0,57-1760



Fig. 2 / 2

RAS-0,57-1762



Fig. 3 / 3

RAS-0,57-1764



Fig. 4 / 4

RAS-0,57-1766



RAS-0,57-1759

RAS-0,57-1761

RAS-0,57-1763

RAS-0,57-1765

RAS-0,57-1767



EN	Bone Curettes
DE	Scharf Löffel
ES	Curettes á os
FR	Cucharillas cortantes
IT	Curette taglienti

RAS-0,57-1768 RAS-0,57-1770
 RAS-0,57-1769 RAS-0,57-1771

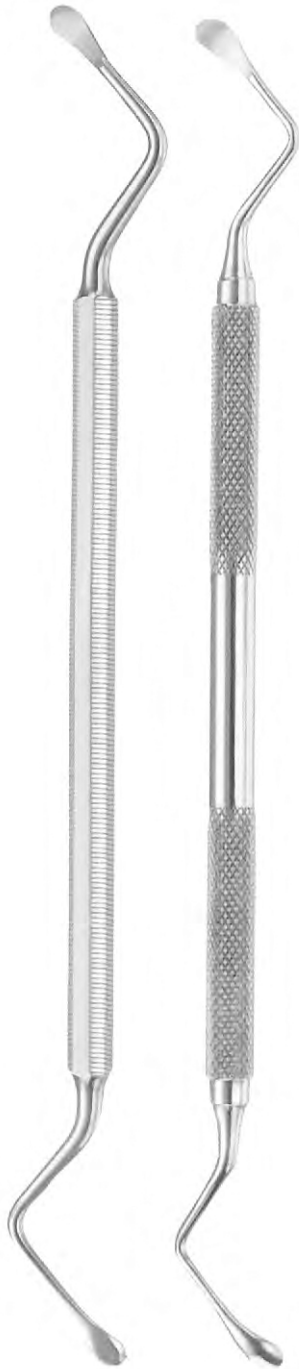

LUCAS
 17 cm/6¾"

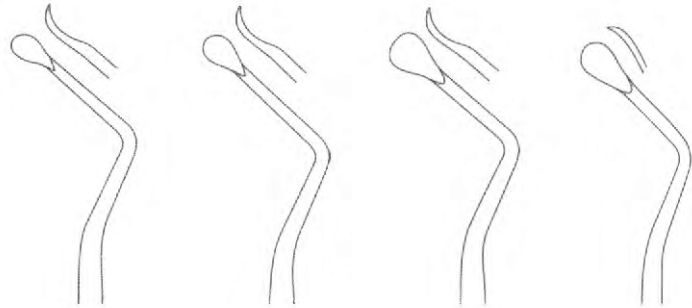

RAS-0,57-1772 RAS-0,57-1774 RAS-0,57-1776 RAS-0,57-1778
 RAS-0,57-1773 RAS-0,57-1775 RAS-0,57-1777 RAS-0,57-1779
 Fig. 1 / 1 Fig. 2 / 2 Fig. 3 / 3 Fig. 4 / 4

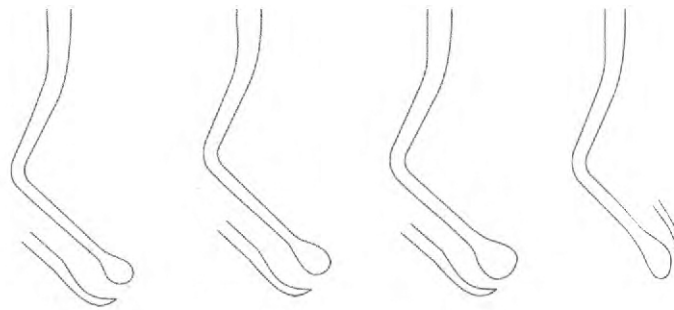



Fig. 4



Fig. 5



Fig. 1



Fig. 2



Fig. 3



Fig. 4



MEAD
RAS-0,57-1780



MEAD
RAS-0,57-1781



RAS-0,57-1782

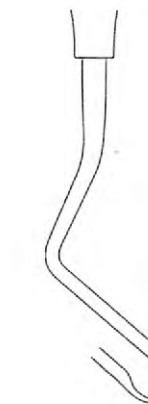

JMLLER-COLBURN
RAS-0,57-1783

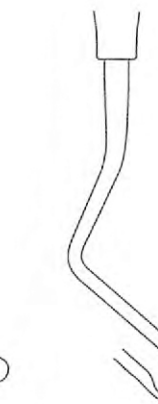

JMLLER-COLBURN
RAS-0,57-1784

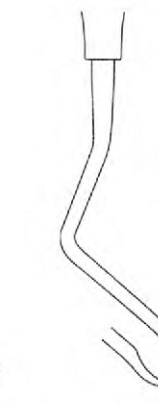

JMLLER-COLBURN
RAS-0,57-1785

- EN** Excavators
- DE** Bagger
- ES** Excavadoras
- FR** Pelles
- IT** escavatori

Page 85 to 89



EN	Excavators
DE	Exkavatoren
ES	Excavateurs
FR	Excavadores
IT	Escavatori

EXCAVATORS

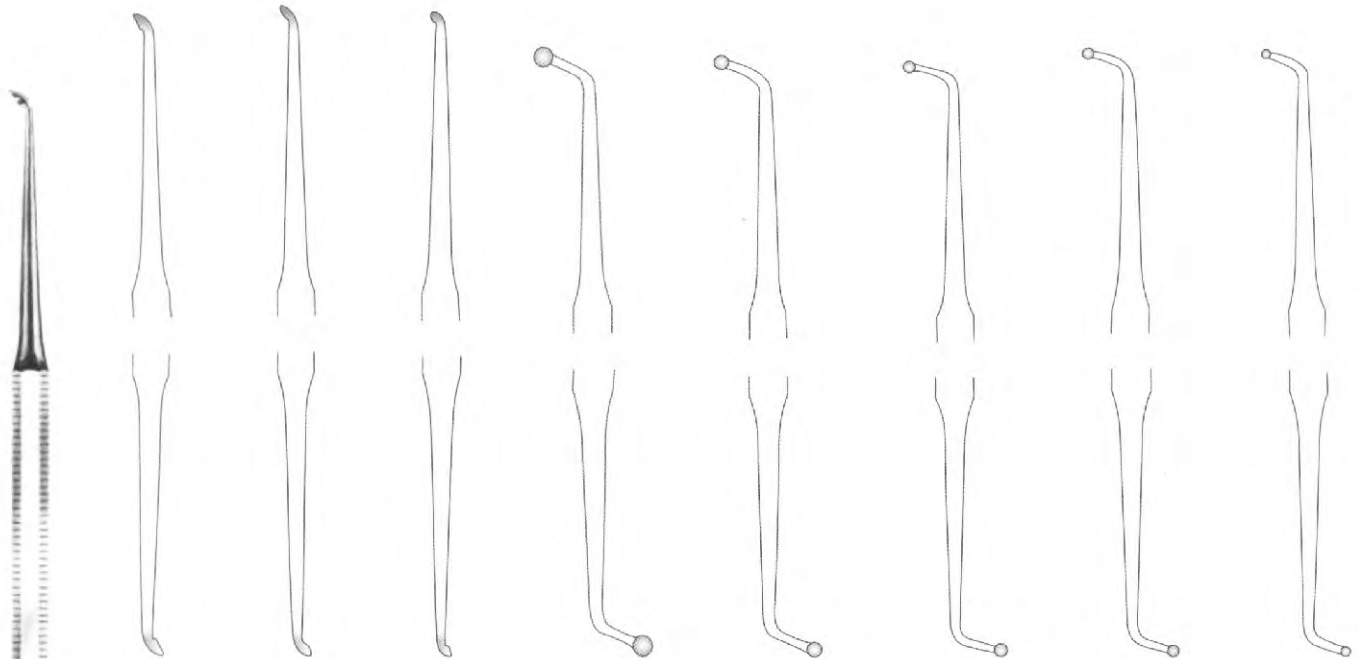

RAS-0,58-1801 Fig. 73/74 RAS-0,58-1802 Fig. 74/111 RAS-0,58-1803 Fig. 111/112 RAS-0,58-1804 Fig. 113/114 RAS-0,58-1805 Fig. 115/116 RAS-0,58-1806 Fig. 117/118 RAS-0,58-1807 Fig. 119/120

58-1800 Fig.72/73

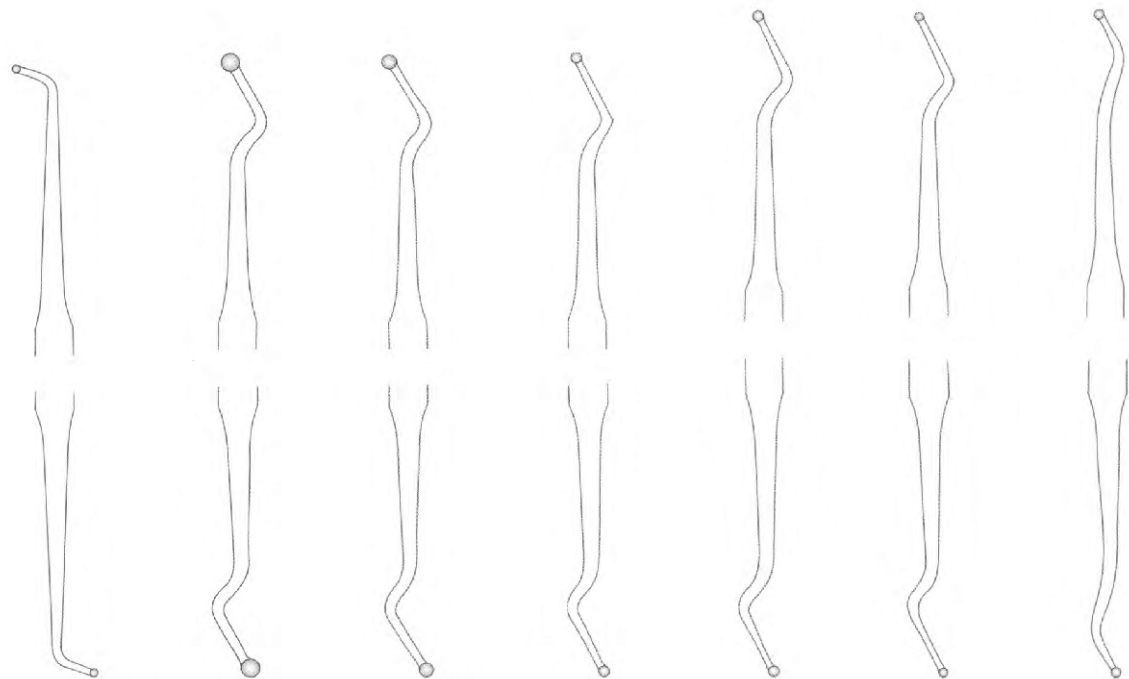

5.5 mm RAS-0,58-1809 Fig.123/124 RAS-0,58-1810 Fig.125/126 RAS-0,58-1811 Fig.127/128 RAS-0,58-1812 Fig.129/130 RAS-0,58-1813 Fig.131/132 RAS-0,58-1814 Fig.133/134 RAS-0,58-1815 Fig.155/156

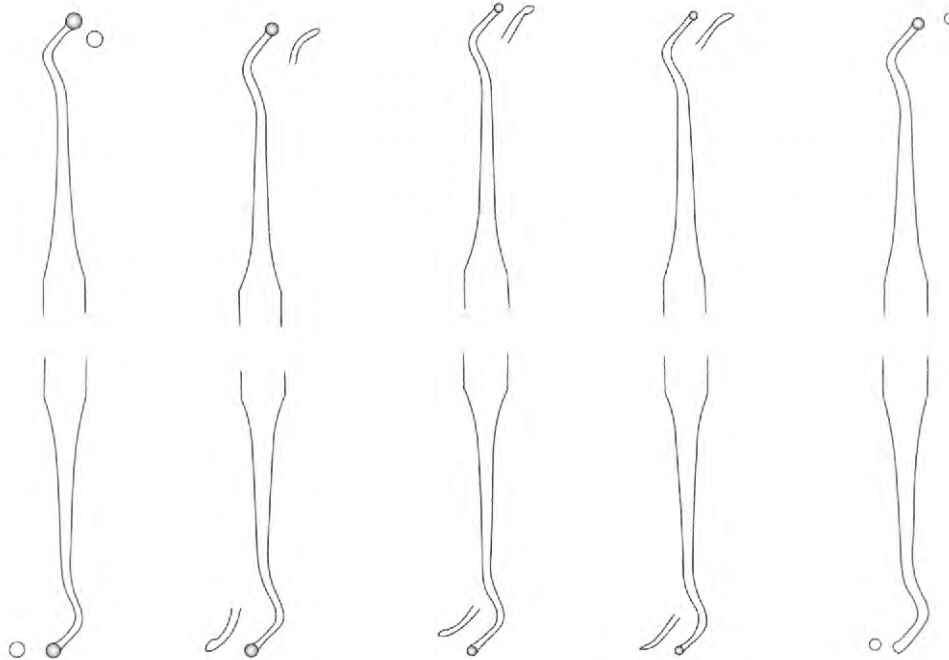

RAS-0,58-1816 Fig.139/140
 RAS-0,58-1817 Fig.141/142
 RAS-0,58-1818 Fig.159/160
 RAS-0,58-1819 Fig.161/162
 RAS-0,58-1820 Fig.165/166

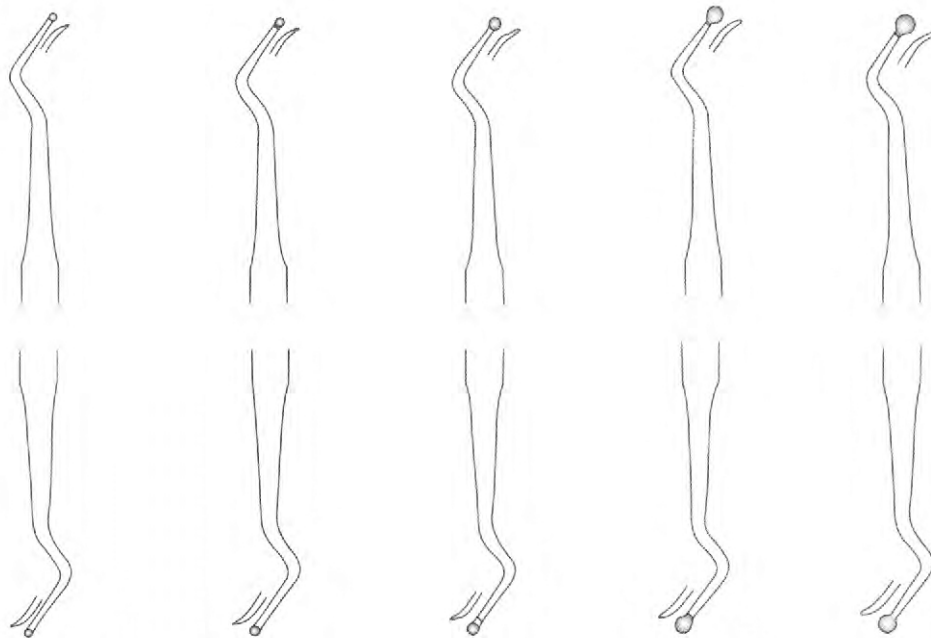

RAS-0,58-1821 Fig.171/172
 RAS-0,58-1822 Fig.173/174
 RAS-0,58-1823 Fig.175/176
 RAS-0,58-1824 Fig.177/178
 RAS-0,58-1825 Fig.179/180

EN	Excavators
DE	Exkavatoren
ES	Excavateurs
FR	Excavadores
IT	Escavatori

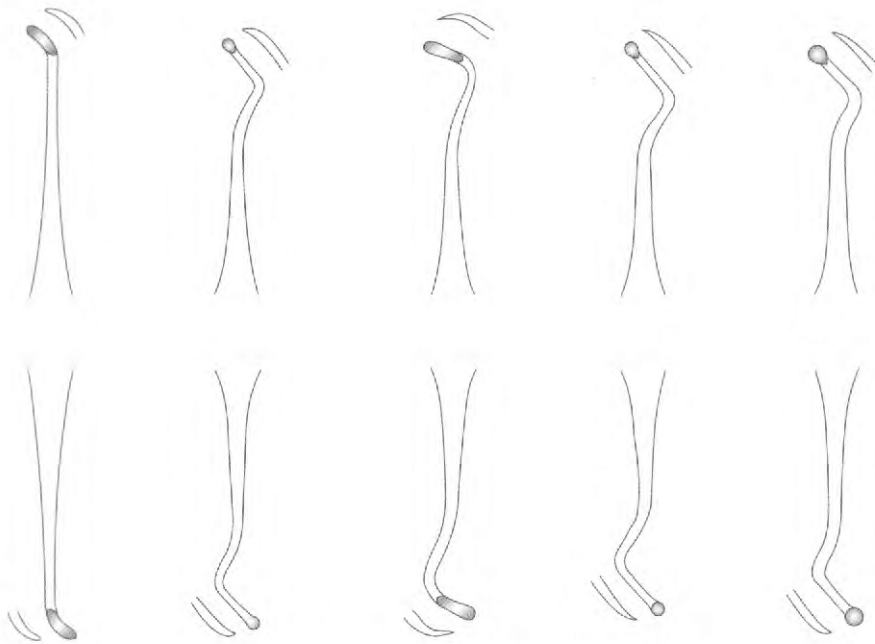

RAS-0,58-1826 Fig. 5
 RAS-0,58-1827 Fig. 13
 WHITE RAS-0,58-1828 Fig. 14
 RAS-0,58-1829 Fig. 15
 RAS-0,58-1830 Fig. 17

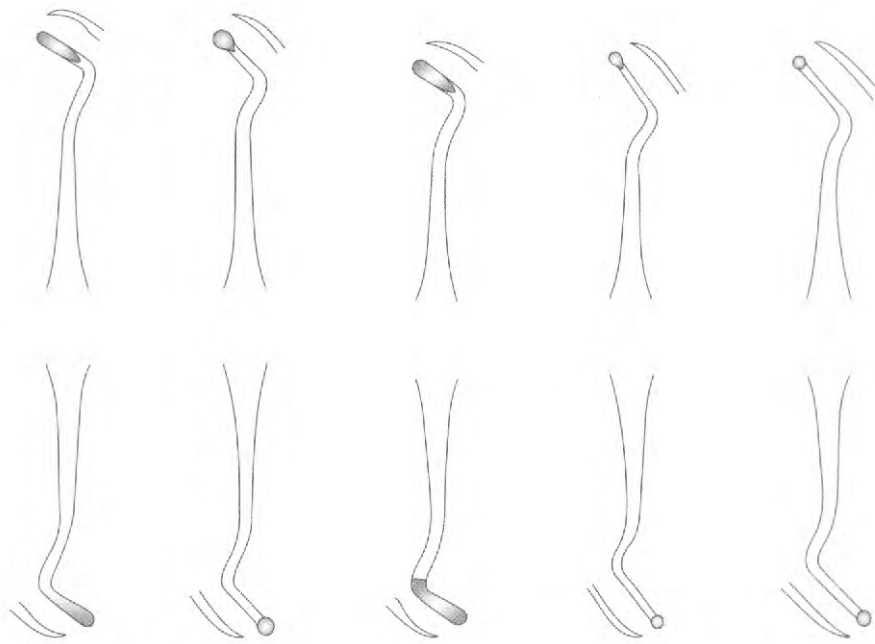

RAS-0,58-1831 Fig. 18
 RAS-0,58-1832 Fig. 19
 WHITE RAS-0,58-1833 Fig. 20
 RAS-0,58-1834 Fig. 23
 RAS-0,58-1835 Fig. 25



Ø6
mm

H1
Ø9,5
mm



Fig. 5

RAS-0,58-1836



Fig. 13

RAS-0,58-1837



Fig. 14

RAS-58-1838



Fig. 17

RAS-58-1839

H1

RAS-58-40

RAS-58-41

RAS-58-42

RAS-58-43



Fig. 18

RAS-58-44



Fig. 31

RAS-58-45



Fig. 33

RAS-58-46



Fig. 35

RAS-58-47

H1

RAS-58-48

RAS-58-49

RAS-58-50

RAS-58-51

EN	Excavators
DE	Exkavatoren
ES	Excavateurs
FR	Excavadores
IT	Escavatori

EXCAVATORS

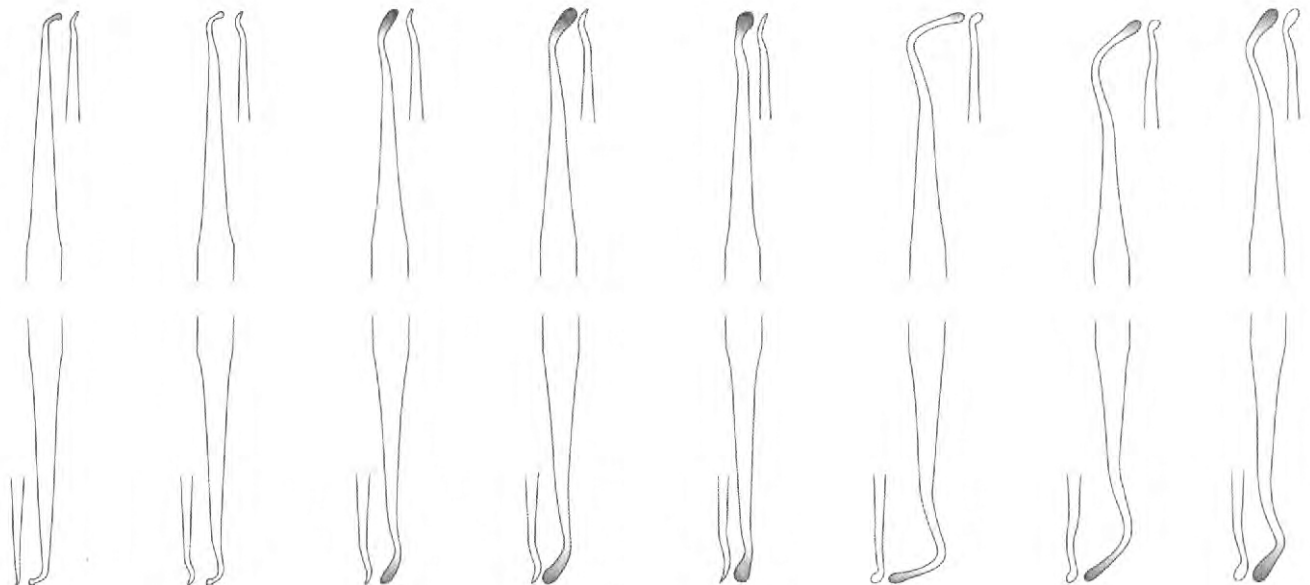

RAS-58-53 Fig. 7/8 RAS-58-54 Fig. 9/10 RAS-58-55 Fig. 11/12 **DARBY-PERRY** RAS-58-56 Fig. 13/14 RAS-58-57 Fig. 15/16 RAS-58-58 Fig. 17/18 RAS-58-59 Fig. 19/20 RAS-58-60 Fig. 21/22

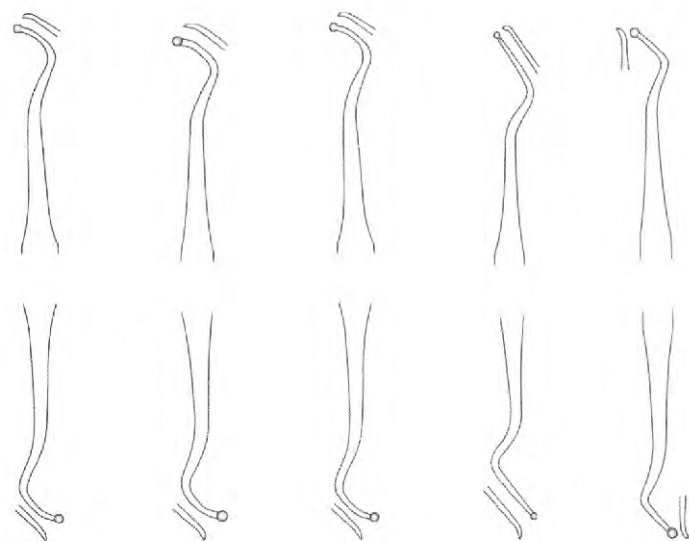
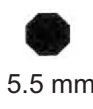

RAS-58-52 Fig. 5/6

RAS-58-61 Fig. 4/5 RAS-58-62 Fig. 6/7 **GILLET** RAS-58-63 Fig. 7/8 RAS-58-64 Fig. 12/13 RAS-58-65 Fig. 14/15

EN	Wax Proclein
DE	Wachs-Porzellan
ES	cera Porcelana
FR	Cire Porcelaine
IT	Cera porcellana

Page 90 to 94



EN Wax, porcelain and modelling carvers
 DE Wachs-, Porzellan- und Modellierinstrumente
 ES Instrumentos A modeler
 FR Talladores y espátulas para cera, porcelana y modelar
 IT Strumenti per modellare

MODELLING CARVERS



5,5 mm



H1
 Ø9,5 mm



RAS-59-1901 Fig. 1



RAS-59-1902 Fig. 2



RAS-59-1903 Fig. 3



RAS-59-1904 Fig. 4



RAS-59-1905 Fig. 5



RAS-59-1906H RAS-59-1907H RAS-59-1908H RAS-59-1909H RAS-59-1910H

Aluminium

RS-59-1911

RS-59-1912

RS-59-1913

RS-59-1914

RS-59-1915

gold

green

blue

red

silver

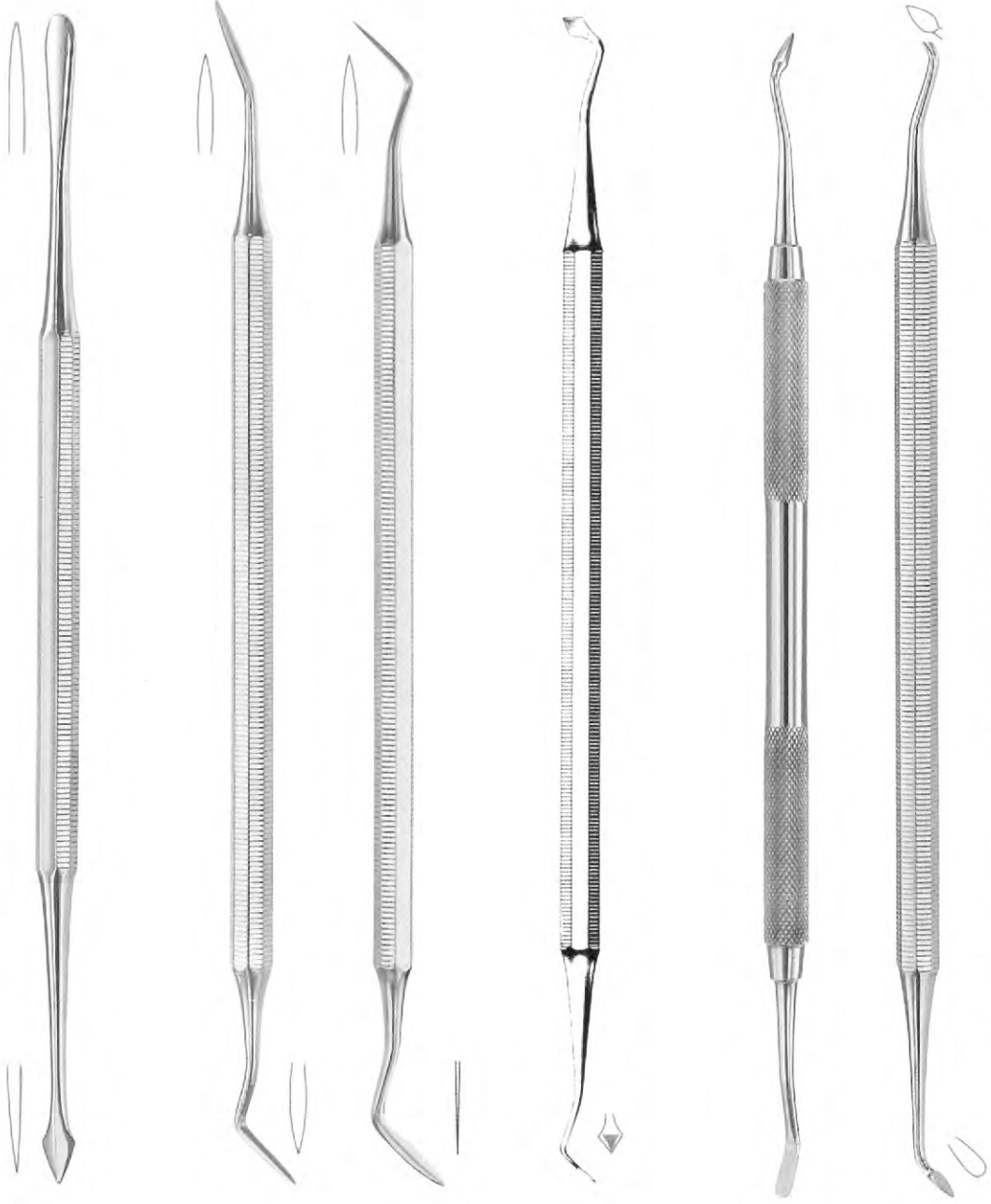

GRITMAN
RAS-59-1916

WARD
RAS-59-1917 Fig. 1
RAS-59-1918 Fig. 2

FRAHM
RAS-59-1919

SHOSHAN
RAS-59-1920 SHO-A
W.A.C.D
RAS-59-1921

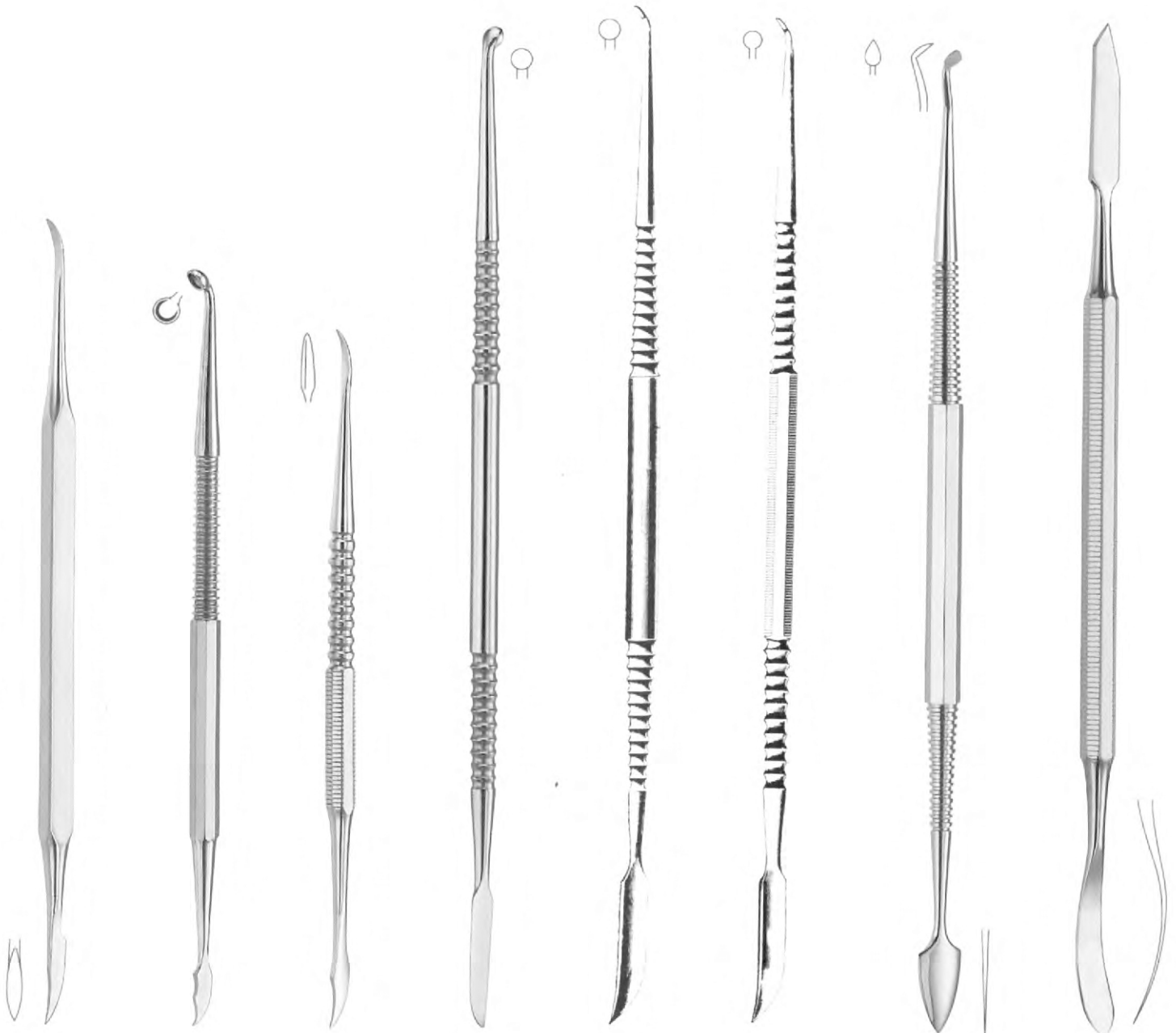

HYLIN
RAS-59-1922

ZAHLE
RAS-59-1923

RAS-59-1924

RAS-59-1925

LE CRON
RAS-59-1926

RAS-59-1927

VEHE
RAS-59-1928

FIELDSTAD
RAS-59-1929



ROACH
RAS-59-1930

RIEGNER
RAS-59-1931

RIEGNER
RAS-59-1932

RAS-59-1933
Fig. 1

RAS-59-1934
Fig. 2

FRAHM
RAS-59-1935
Fig. 6

RAS-59-1936
Fig. 10

RAS-59-1937
Fig. 6/10

EN Wax, porcelain and modelling carvers
 DE Wachs-, Porzellan- und Modellierinstrumente
 ES Instrumentos A modeler
 FR Talladores y espátulas para cera, porcelana y modelar
 IT Strumenti per modellare

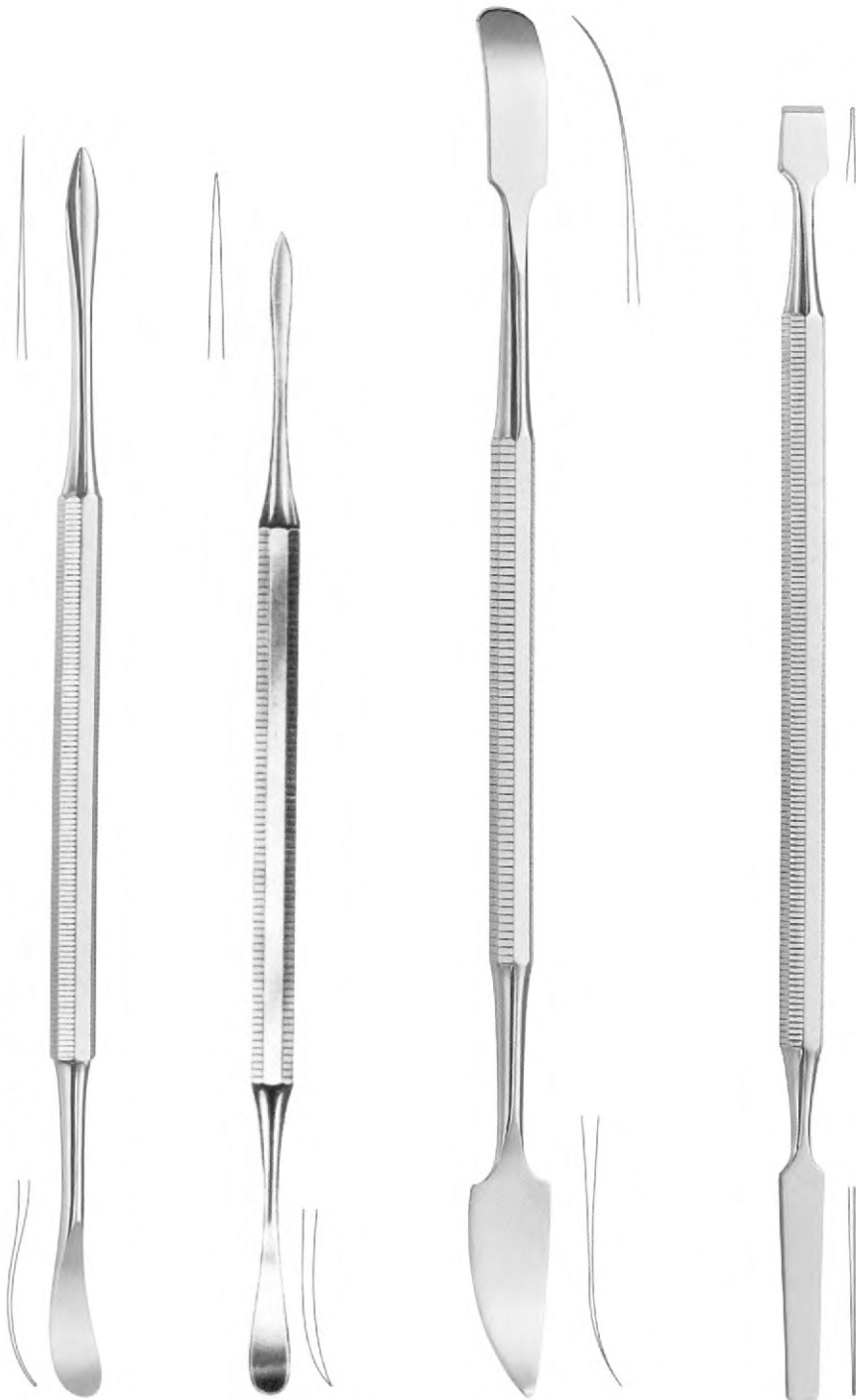

BEALE
 RAS-59-1938 RAS-59-1939
 Fig. 7A

GRITMAN
 RAS-59-1940
 19,5 cm/7 ¾"

WESTON
 RAS-59-1941

- EN** Filling Instruments
- DE** Füllungsinstrumente
- ES** Actos de llenado
- FR** Instruments de remplissage
- IT** Strumenti di riempimento

Page 95 to 105



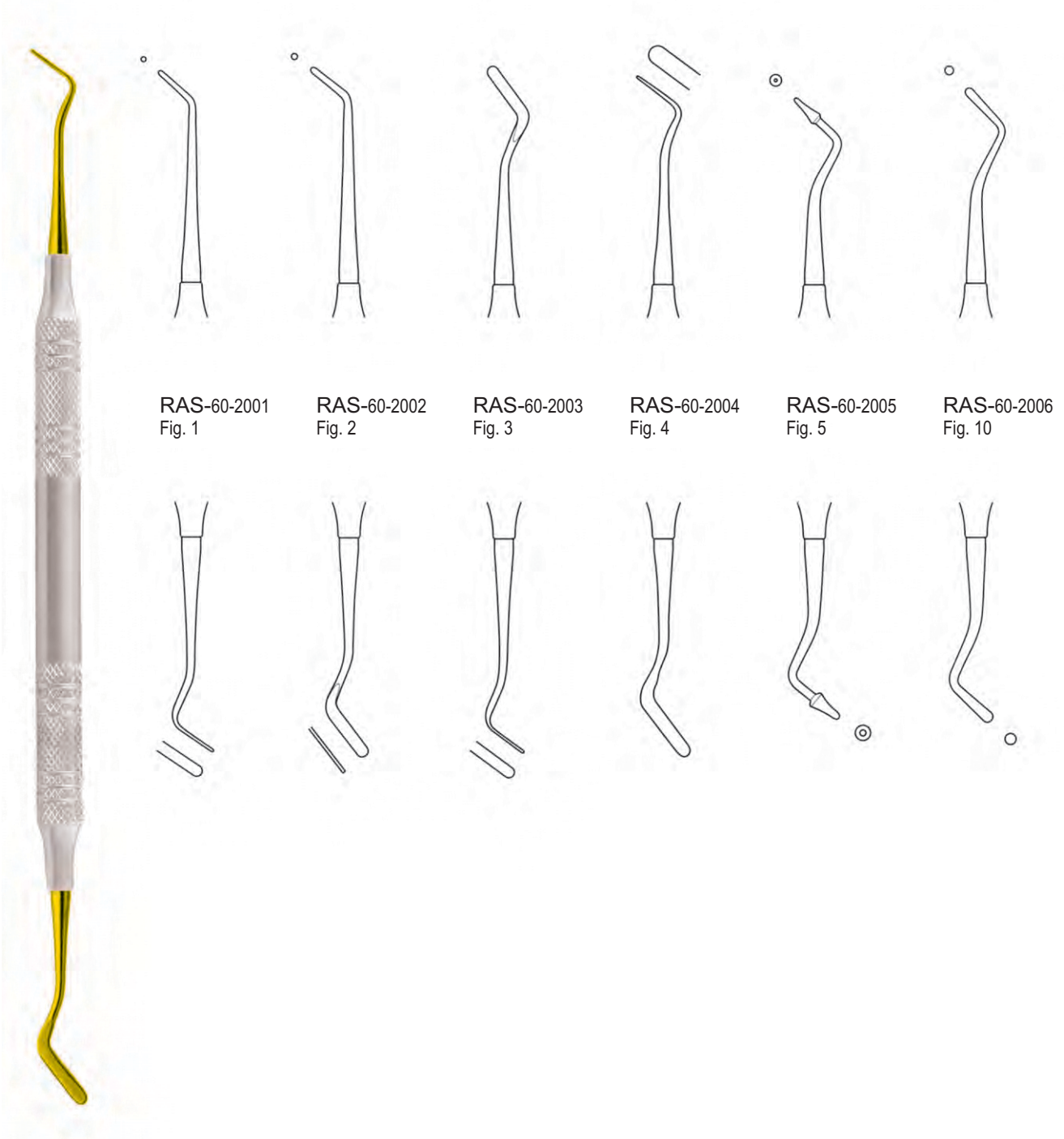

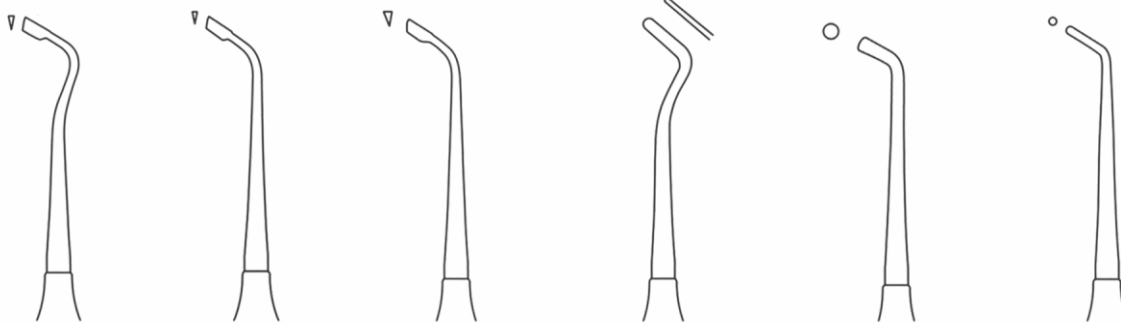

RAS-60-2007
Fig. 1
Felt

RAS-60-2008
Fig. 2
Felt

RAS-60-2009
Fig. 3
Felt

RAS-60-2010
Fig. 4
Felt

RAS-60-2011
Fig. 5
Felt

RAS-60-2012
Fig. 6
Felt

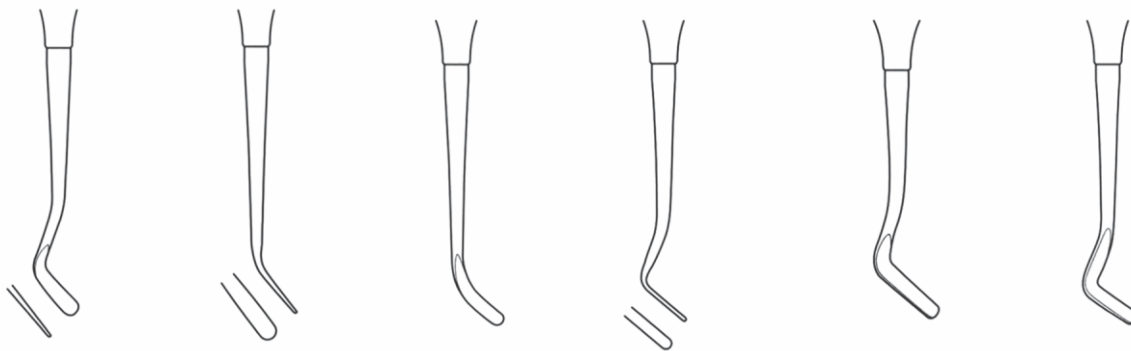



JM-60-2013
 Fig. 1
 Goldstein



RAS-60-2014
 Fig. 2
 Goldstein



RAS-60-2015
 Fig. 3
 Goldstein



RAS-60-2016
 Fig. 4
 Goldstein



RAS-60-2017
 Fig. 9/10



RAS-60-2018
 Fig. 11/12



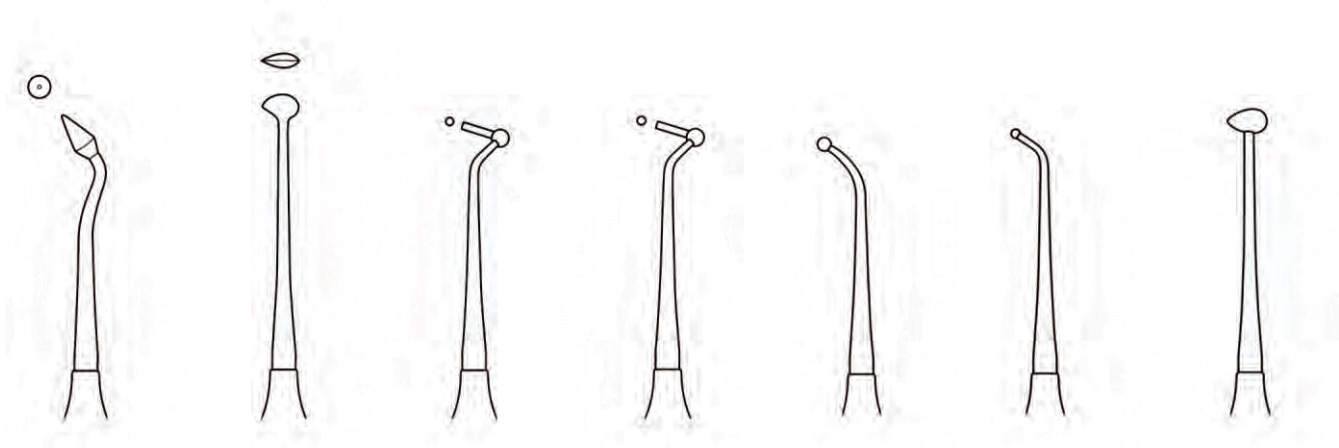

RAS-60-2019
Fig. SB

RAS-60-2020
Fig. 29/2B

RAS-60-2021
Fig. L1
Loesche

RAS-60-2022
Fig. L2
Loesche

RAS-60-2023
Fig. 18
Ball Burnisher

RAS-60-2024
Fig. 26/27S
Ball Burnisher

RAS-60-2025
Fig. 28/29
Ball Burnisher

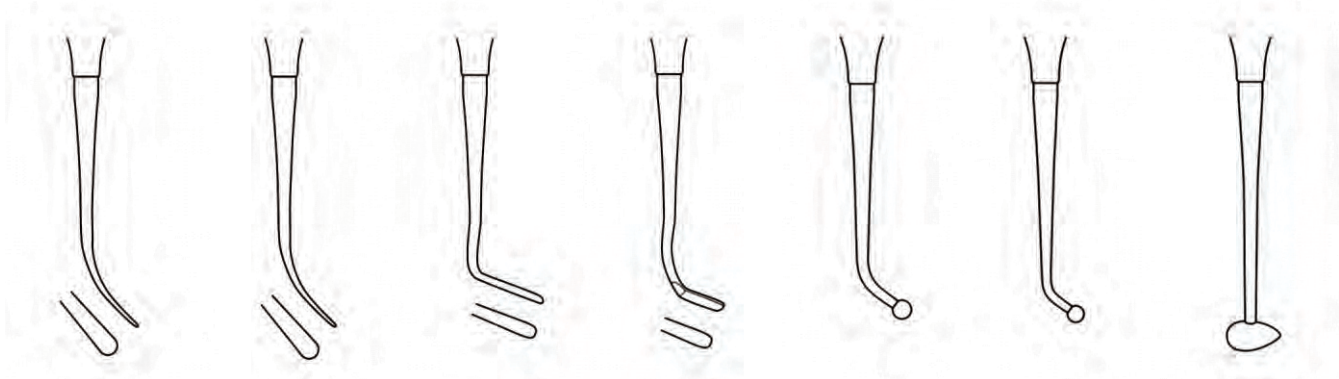

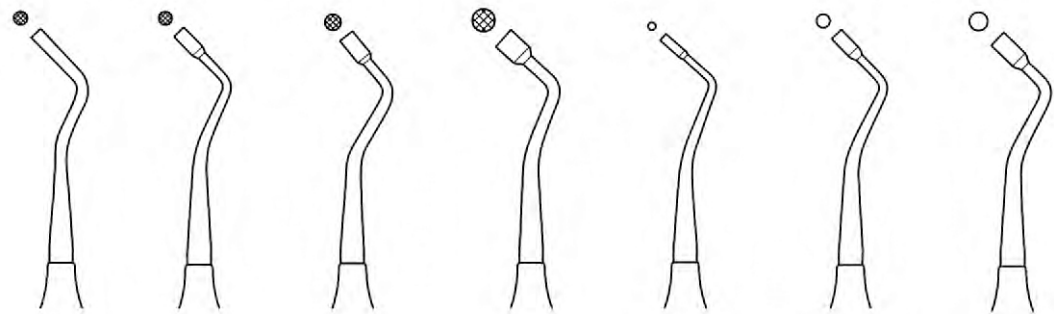

RAS-60-2026 Fig. 1S RAS-60-2027 Fig. 2S RAS-60-2028 Fig. 3S RAS-60-2029 Fig. 4S RAS-60-2030 Fig. 1P RAS-60-2031 Fig. 2P RAS-60-2032 Fig. 3P

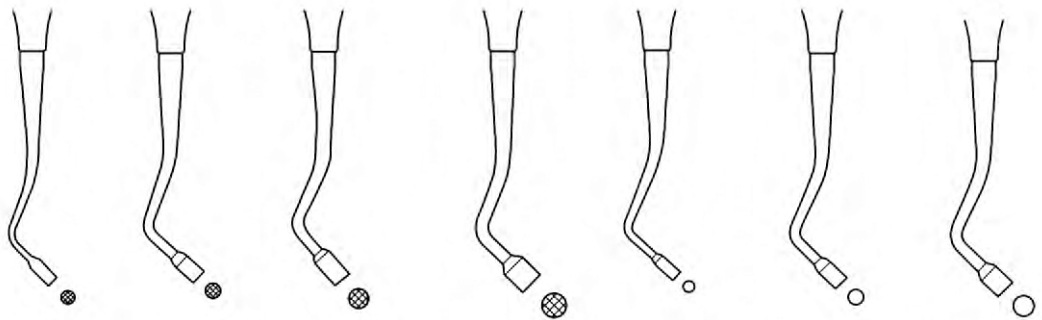

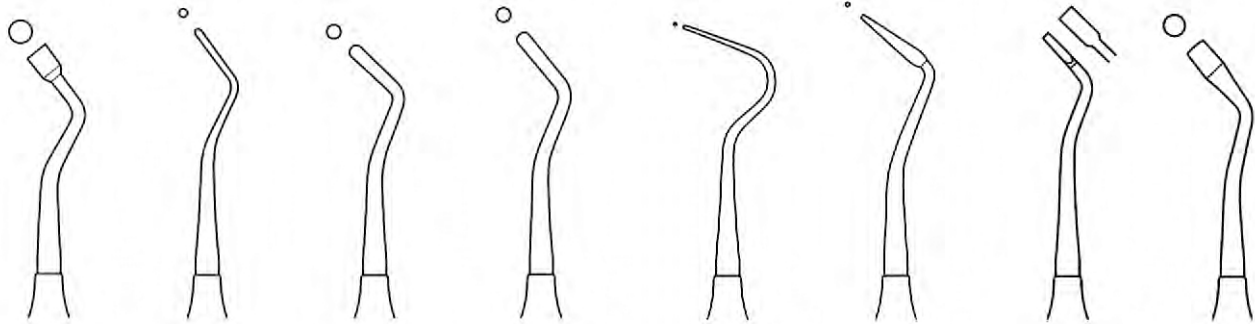

RAS-60-2033 Fig. 4P	RAS-60-2034 Fig. 1D	RAS-60-2035 Fig. 2D	RAS-60-2036 Fig. 3D	RAS-60-2037 Fig. M1 Markley	RAS-60-2038 Fig. M2	RAS-60-2039 Fig. M3	RAS-60-2040 Fig. M4
------------------------	------------------------	------------------------	------------------------	-----------------------------------	------------------------	------------------------	------------------------

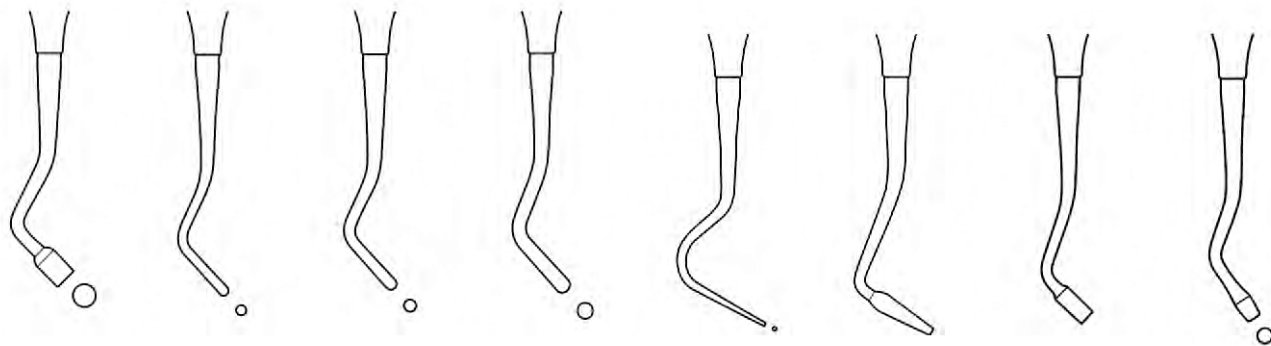

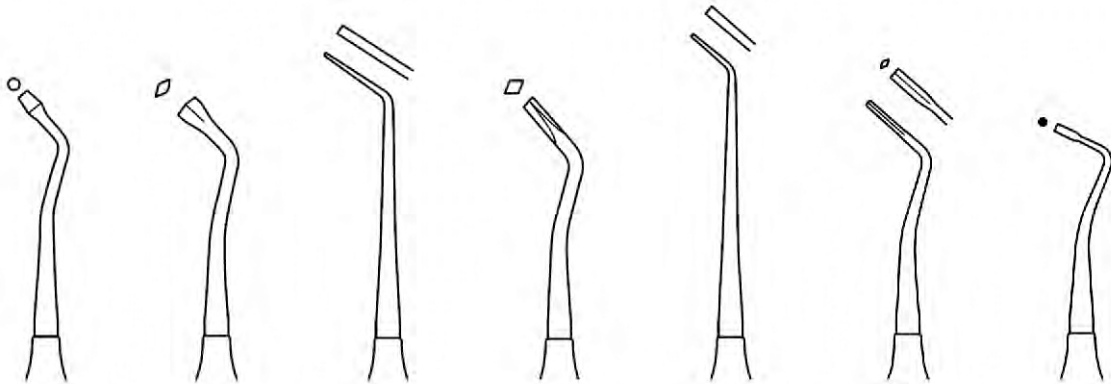

RAS-60-2041
Fig. M5

RAS-60-2042
Fig. M6

RAS-60-2043
Fig. H1
Hollenback

RAS-60-2044
Fig. H2
Hollenback

RAS-60-2045
Fig. H3
Hollenback

RAS-60-2046
Fig. H4
Hollenback

RAS-60-2047
Fig. MQ 1S

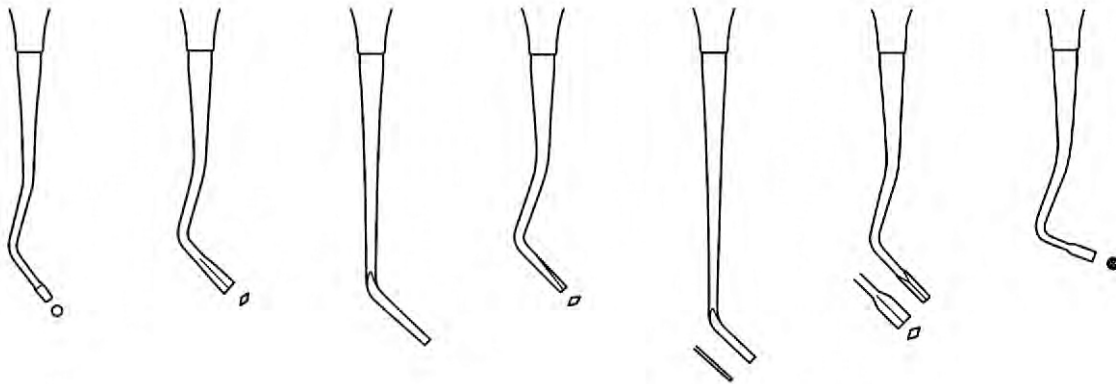

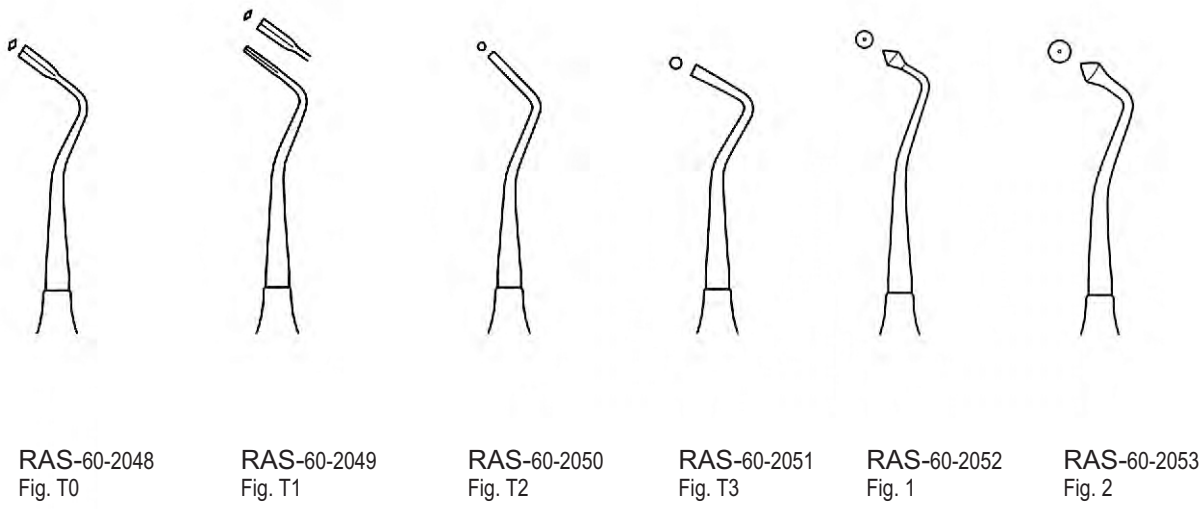

RAS-60-2048
Fig. T0

RAS-60-2049
Fig. T1

RAS-60-2050
Fig. T2

RAS-60-2051
Fig. T3

RAS-60-2052
Fig. 1

RAS-60-2053
Fig. 2

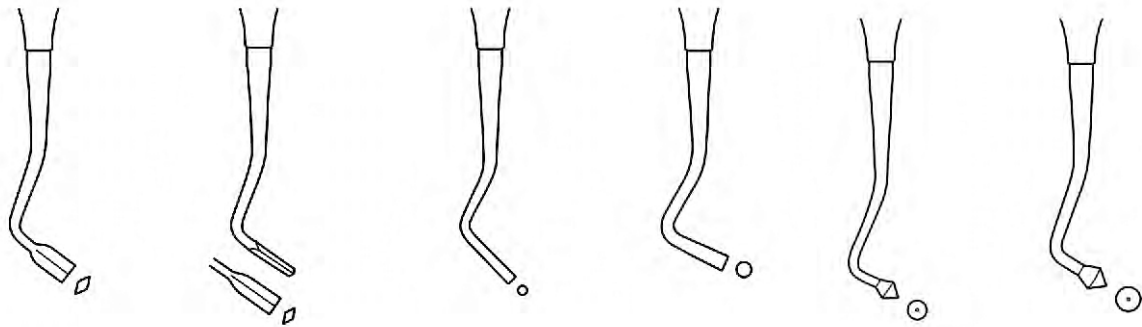

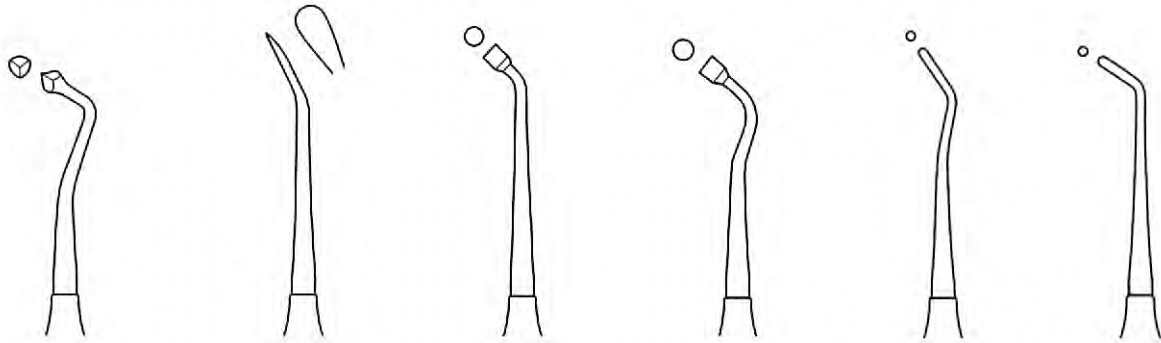

RAS-60-2054
Fig. 3

RAS-60-2055
Fig. WO 1
Woodson

RAS-60-2056
Fig. WO 2
Woodson

RAS-60-2057
Fig. WO 3
Woodson

RAS-60-2058
Fig. L2
Ladmore

RAS-60-2059
Fig. L3
Ladmore

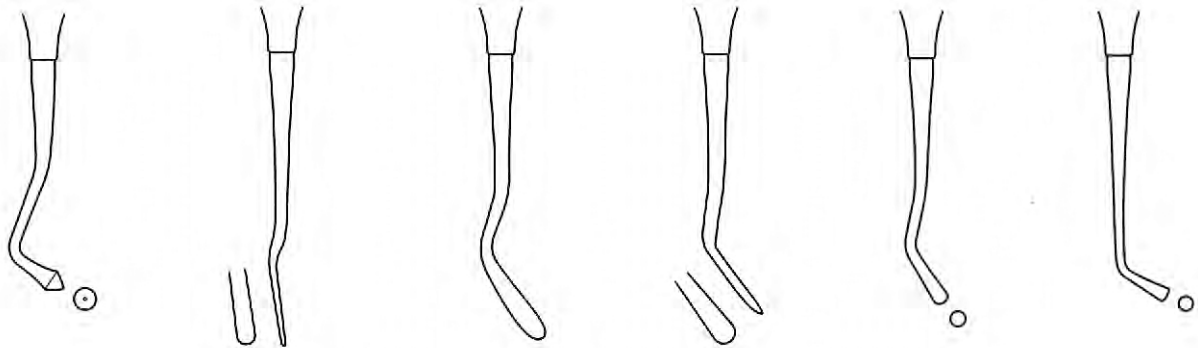



RAS-60-2060
Fig. 1
Ward



RAS-60-2061
Fig. 2
Ward

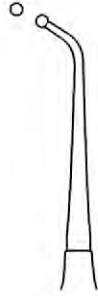

RAS-60-2062
Fig. 7A

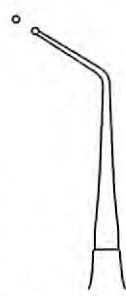

RAS-60-2063
Fig. 19

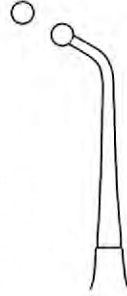

RAS-60-2064
Fig. 7B



RAS-60-2065
Fig. 6



RAS-60-2066
Fig. 11

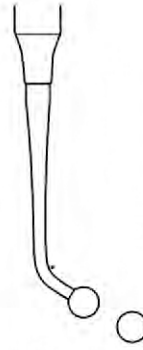
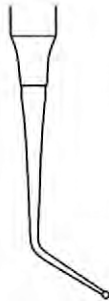
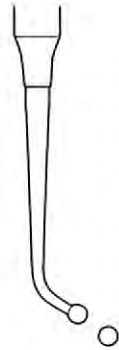

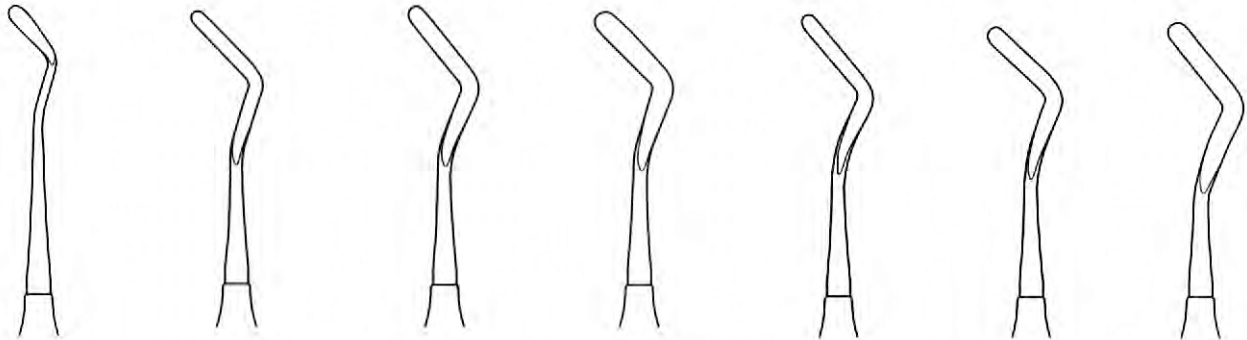

RAS-60-2067
Fig. 179

RAS-60-2068
Fig. 1
2 mm

RAS-60-2069
Fig. 2
2.5 mm

RAS-60-2070
Fig. 3
3 mm

RAS-60-2071
Fig. 11

RAS-60-2072
Fig. 12

RAS-60-2073
Fig. 13

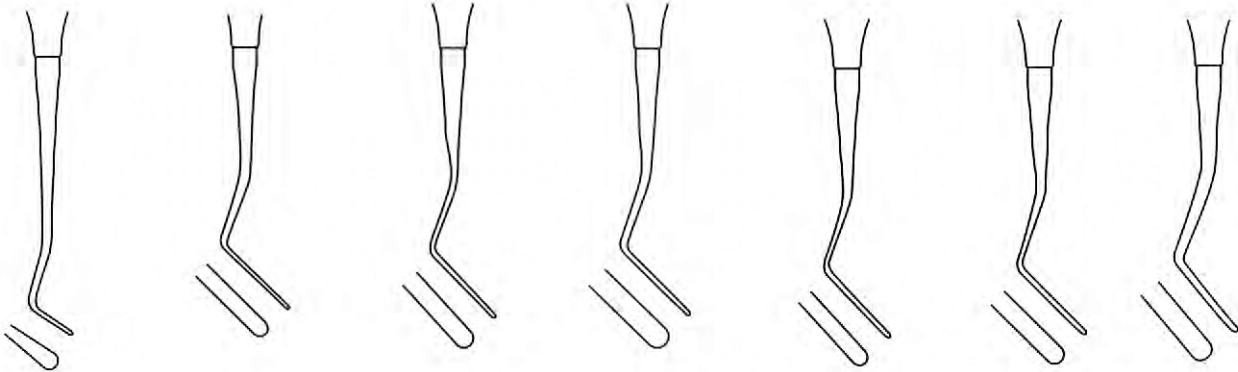

- EN** Gingivectomy Knives
- DE** Gingivektomie Messer
- ES** Cuchillos de gingivectomía
- FR** Couteaux de gingivectomie
- IT** Coltelli per gengivectomia

Page 106 to 107



EN	Periodontal Knives
DE	Parodontale Messer
ES	Cuchillos periodontales
FR	Couteaux parodontaux
IT	Coltelli periodontali

GINGIVECTOMY KNIVES

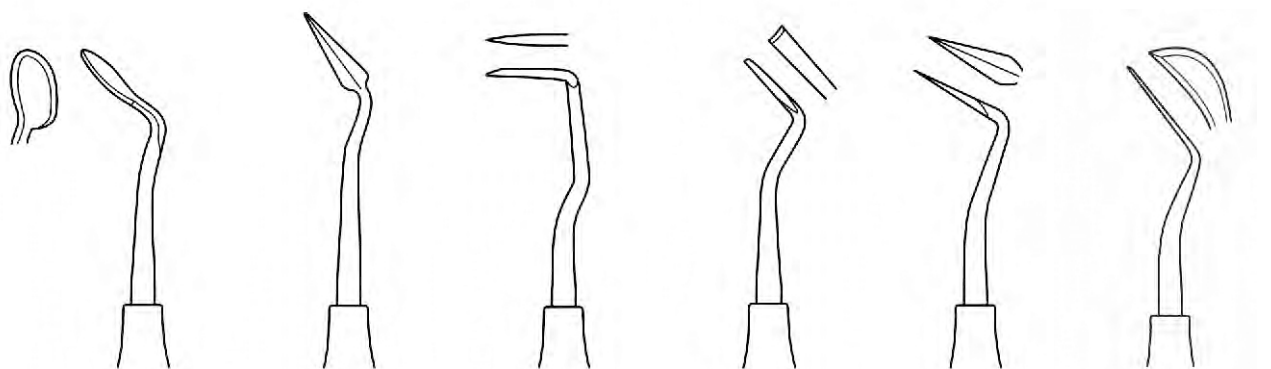

RAS-61-2101
Goldman-Fox
Fig. 7

RAS-61-2102
Goldman-Fox
Fig. 8

RAS-61-2103
Goldman-Fox
Fig. 9

RAS-61-2104
Goldman-Fox
Fig. 10

RAS-61-2105
Goldman-Fox
Fig. 11

RAS-61-2106
Kirkland
Fig. 15K/16K

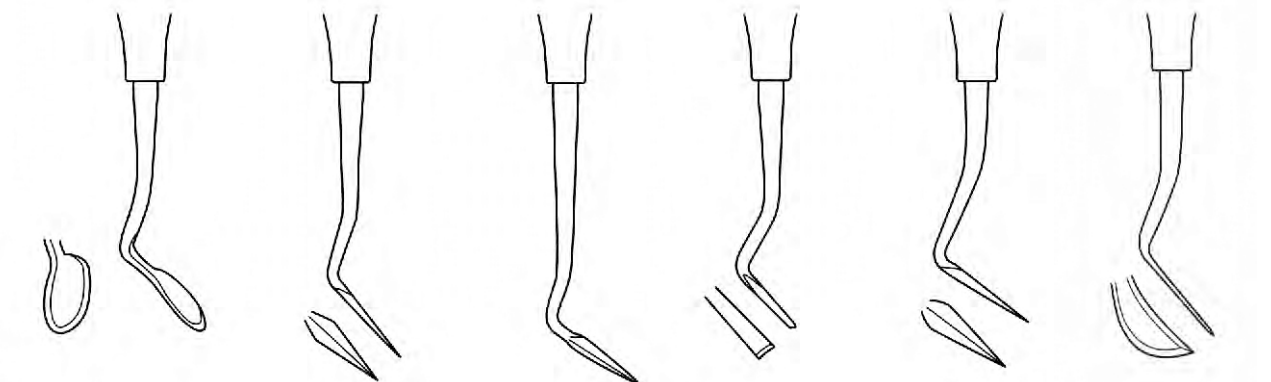

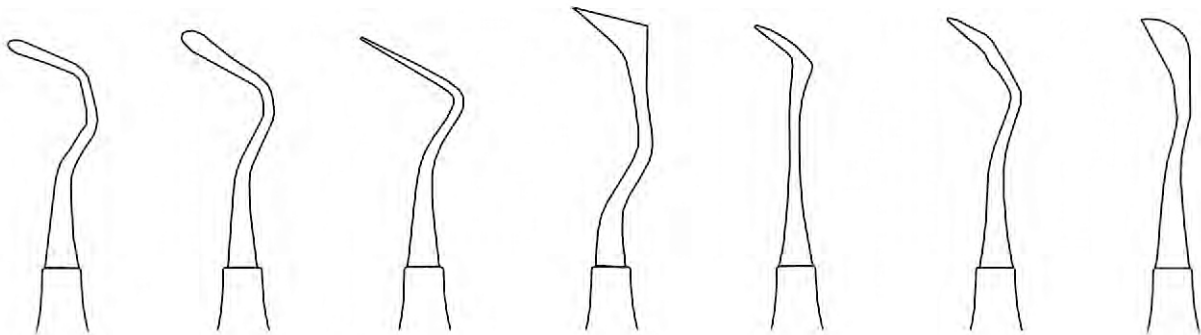

RAS-61-2107
Fig. 1
Reddy Thin

RAS-61-2108
Fig. 2
Reddy Thin

RAS-61-2109
Fig. 1/2
Sanders

RAS-61-2110
Fig. 19/20
USC Towner

RAS-61-2111
Fig. CK-3
Crane Kaplan

RAS-61-2112
Fig. CK-6
Crane Kaplan

RAS-61-2113
Fig. 1/2
Solt

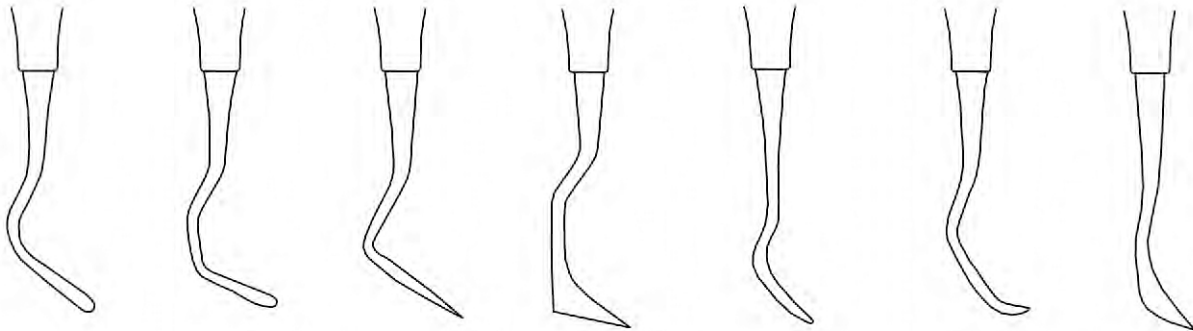

- EN** Cement Spatulas
- DE** Zementspatel
- ES** Espátulas de cemento
- FR** Spatules de ciment
- IT** Spatole di cemento

Page 108 to 112



EN Cement Spatulas

DE Zementspatel

ES Espátulas de cemento

FR Spatules de ciment

IT Spatole di cemento



RAS-62-2151
Fig. 26
Distal

RAS-62-2152
Fig. 27
Mesial

RAS-62-2153
Fig. 29
Mesial

RAS-62-2154
Fig. 29
Mesial

RAS-62-2155
Fig. 77/78
Distal

RAS-62-2156
Mesial
54-1142-00

RAS-62-2157
Fig. 28
Distal

Wooden Handle



RAS-62-2158
Fig. 28
Distal



RAS-62-2159
Fig. 28
Distal



RAS-62-2160
Fig. 28
Distal



RAS-62-2161
Fig. 28
Distal



RAS-62-2162
Fig. 28
Distal

EN	Cement Spatulas
DE	Zementspatel
ES	Espátulas de cemento
FR	Spatules de ciment
IT	Spatole di cemento



RAS-0,62-2163
Fig. 1



Fig. 2



Fig. 3



Fig. 4



Fig. 5



Fig. 1



Fig. 2
RAS-0,62-2164



Fig. 3

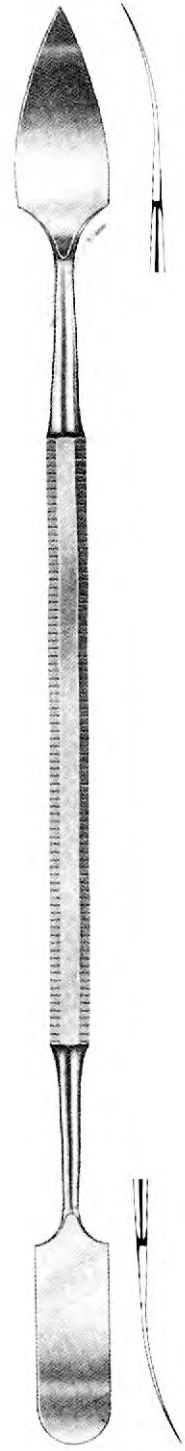

RAS-0,62-2165
Fig. 31
Gritman



RAS-0,62-2166
Fig. 1



Fig. 2



Fig. 3



RAS-0,62-2167
Fig. 1



Fig. 2



Fig. 5



Fig. 3



Fig. 6



Fig. 4



Fig. 7

EN	Cement Spatulas
DE	Zementspatel
ES	Espátulas de cemento
FR	Spatules de ciment
IT	Spatole di cemento

CEMENT SPATULAS



RAS-0,62-2168
Fig. 1



Fig. 2



Fig. 4



Fig. 5



Fig. 322



Fig. 324



RAS-0,62-2170



Fig. 6



Fig. 7



Fig. 8



RAS-0,62-2169
Fig. 313



Fig. 5



Fig. 8



Fig. 24 A



Fig. 25 E



Fig. 11



Fig. 12

EN	Mouth Mirrors
DE	Mundspiegel
ES	Espejos bucales
FR	Bouche Miroirs
IT	Bocca specchi

Page 113 to 115

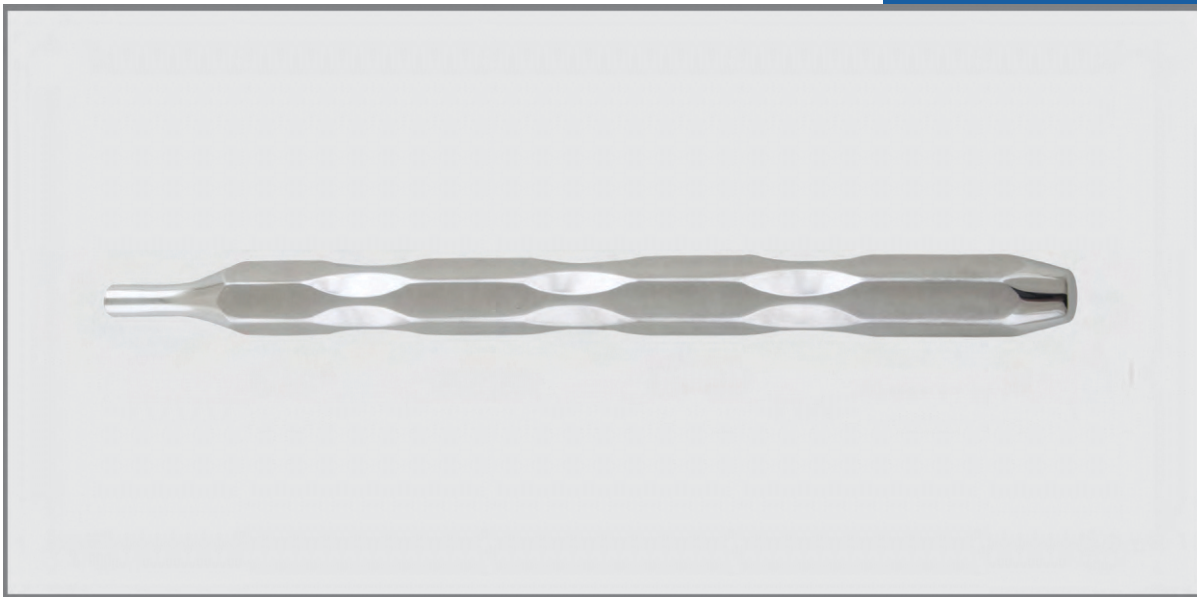

EN	Mouth Mirrors
DE	Mundspiegel
ES	Miroirs á boca
FR	Espejos de boca
IT	Specchietti

Simple Stem



Plain
Magnifying
Front Surface

- 1 = 16 mm
- 3 = 20 mm
- 4 = 22 mm
- 5 = 24 mm

- RAS-0,63-2301-16
- RAS-0,63-2301-20
- RAS-0,63-2301-22
- RAS-0,63-2301-24



Plain
Magnifying
Front Surface

- 4 = 22 mm
- 5 = 24 mm

- RAS-0,63-2302-22
- RAS-0,63-2302-24



Plain
Magnifying
Front Surface

- 3 = 20 mm
- 4 = 22 mm
- 5 = 24 mm

- RAS-0,63-2303-20
- RAS-0,63-2303-22
- RAS-63-2303-24

Cone Socket



Plain
Magnifying
Front Surface

- 3 = 20 mm
- 4 = 22 mm
- 5 = 24 mm

- RAS-63-2304-20
- RAS-63-2304-22
- RAS-63-2304-24



Plain
Magnifying
Front Surface

- 3 = 20 mm
- 4 = 22 mm
- 5 = 24 mm

- RAS-63-2305-20
- RAS-63-2305-22
- RAS-63-2305-24



RAS-63-2306-01
4,5 cm/13/4



RAS-63-2306-02
Handle only

HILGER
RAS-63-2306-00
18 cm/7"



RAS-63-2307-14
Hollow



RAS-63-2308-14
Hollow



RAS-63-2309-14
Hollow



RAS-63-2310-14
Hollow

Mirror handles are available with Cone Socket and Simple Stem Fittings
Metric / US Threads, Please specify while ordering

EN	Mouth mirror handles
DE	Mundspiegelgriff
ES	Manches pour miroirs á bouche
FR	Mangos para espejos de boca
IT	Manici per specchietti



RAS-63-2311-12
Hollow



RAS-63-2312-12
Solid



RAS-63-2313-12
Solid



RAS-63-2314-12
Solid



RAS-63-2315-00
Solid



RAS-63-2316-00
Hollow

Mirror handles are available with Cone Socket and Simple Stem Fittings
Metric / US Threads, Please specify while ordering

- EN** Amalgam Instruments
- DE** Amalgam Instrumente
- ES** Instrumentos de amalgama
- FR** Instruments Amalgam
- IT** Strumenti amalgama

Page 116 to 117

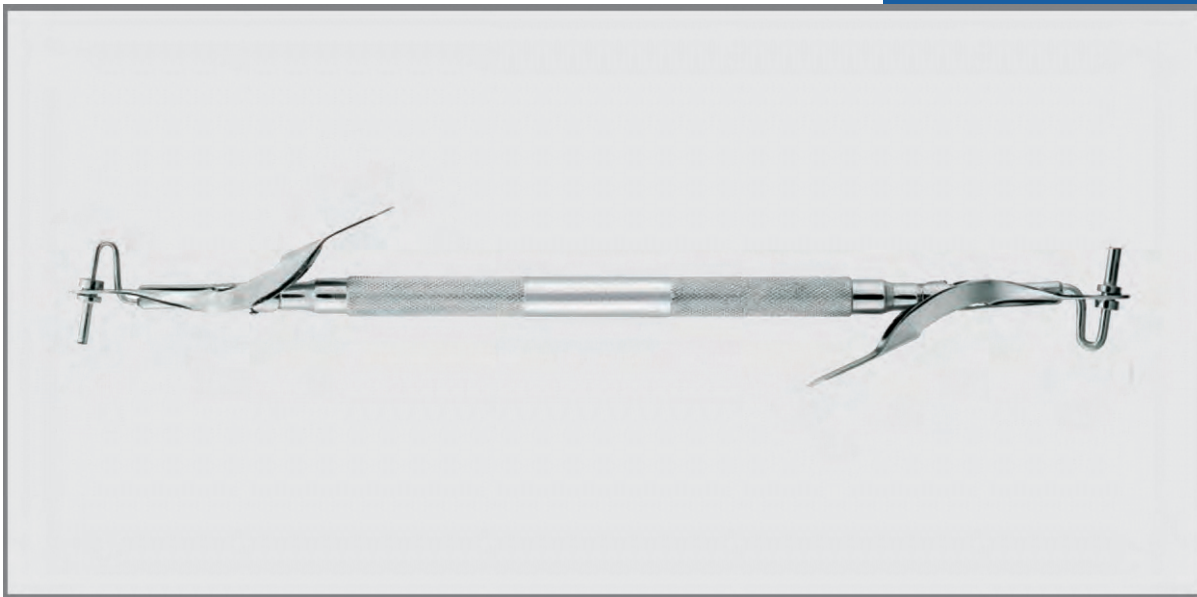

EN Amalgam Guns

DE Knochenfeilen

ES Limes à os

FR Lima para huesos

IT Lima per ossa



¼

with metal tip
with plastic tip

RAS-64-2351
RAS-64-2352

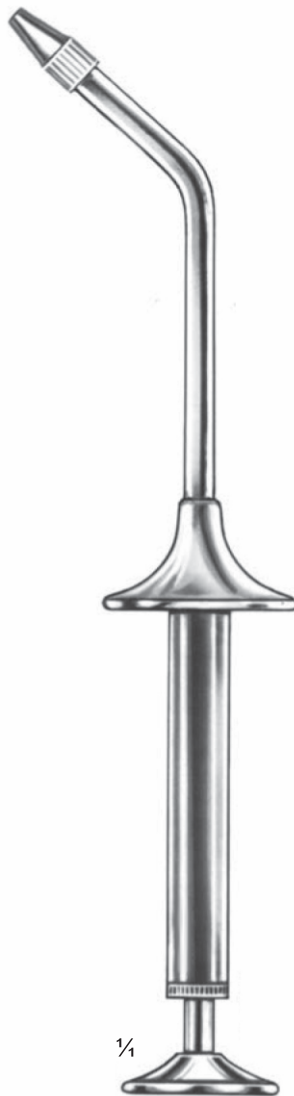

¼

RAS-64-2353
RAS-64-2354

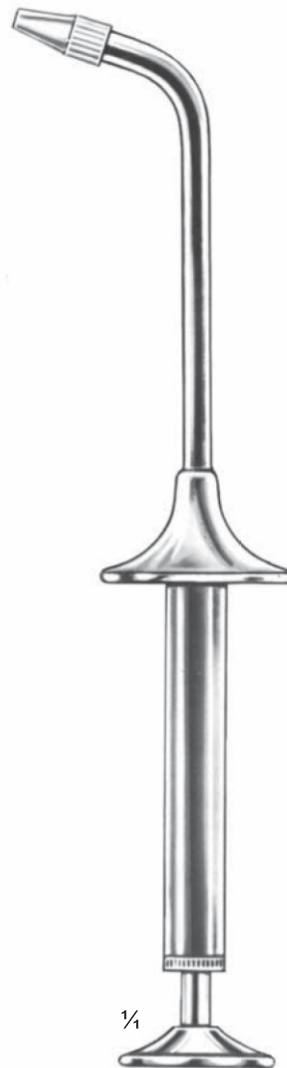

¼

RAS-64-2355
RAS-64-2356



¼

RAS-64-2357
RAS-64-2358

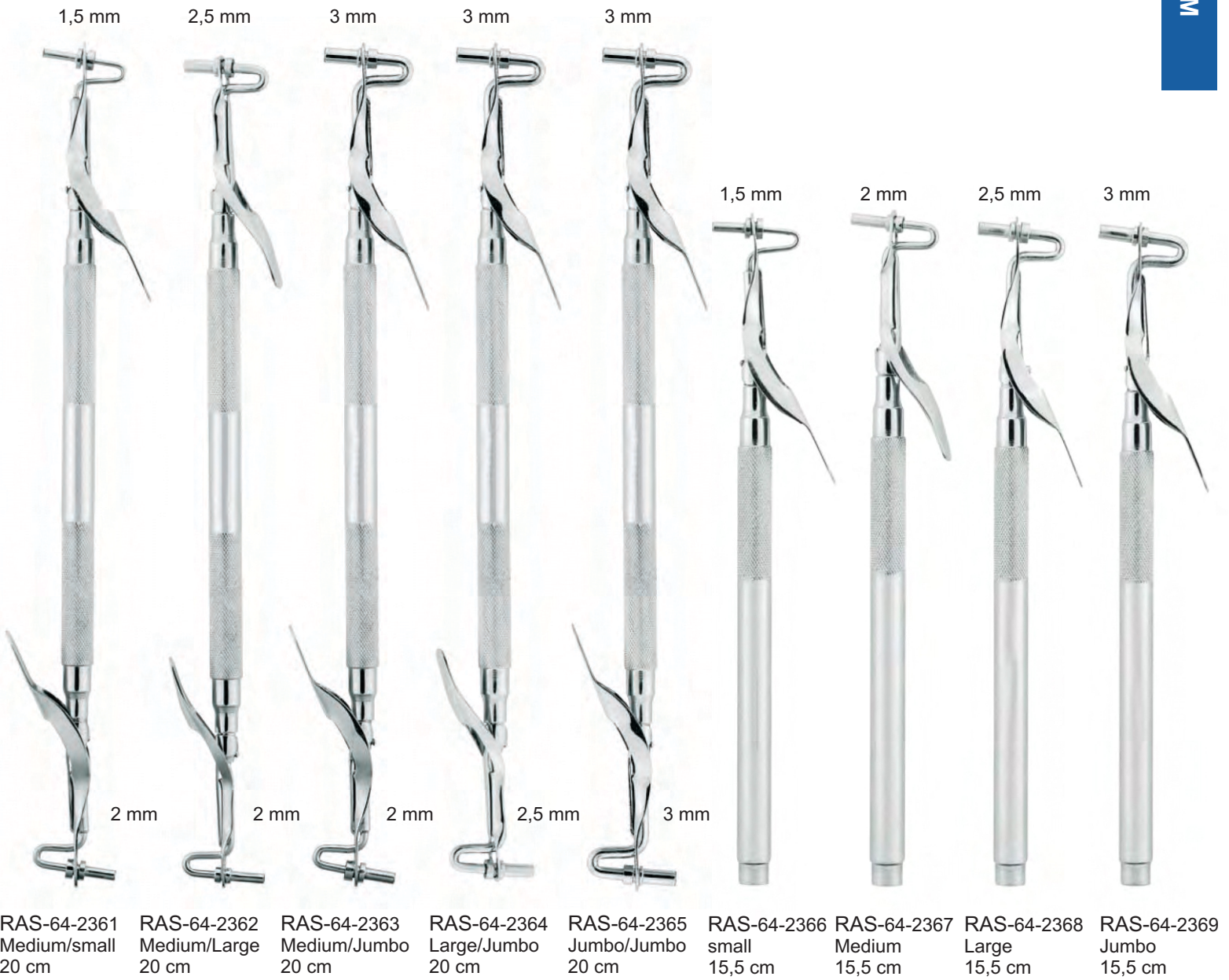

- EN** Matrix Retainers
- DE** Matrix-Halterungen
- ES** Retenedores de matrices
- FR** Retenue de matrice
- IT** Matrix Retainers

Page 118 to 125

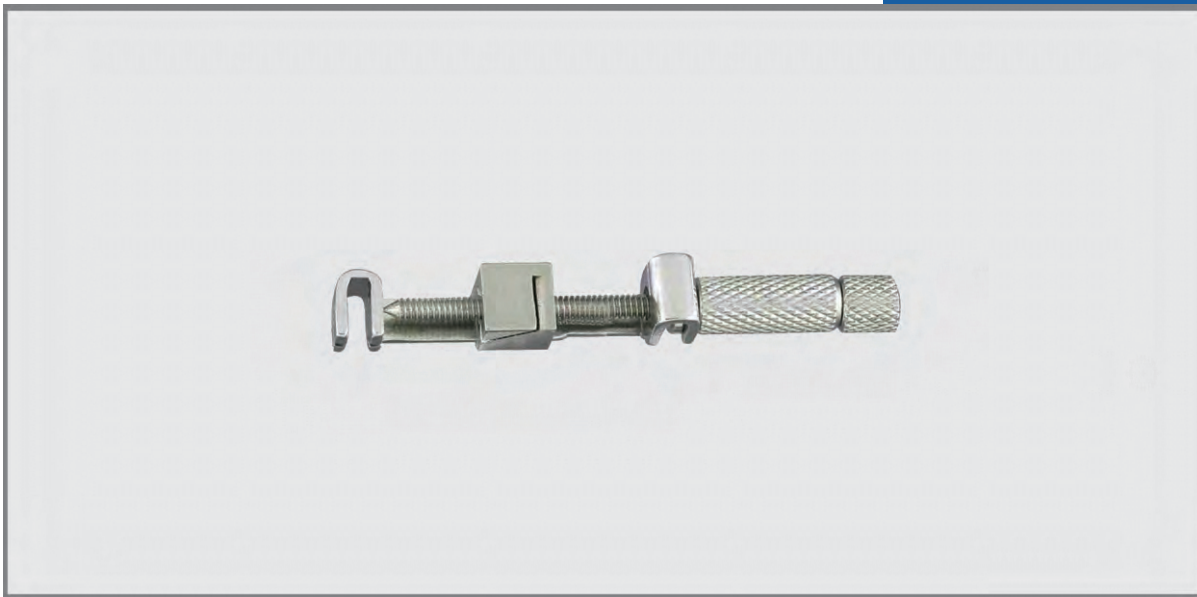

EN	Matrix Retainers
DE	Knochenfeilen
ES	Limes à os
FR	Lima para huesos
IT	Lima per ossa

MATRIX RETAINERS

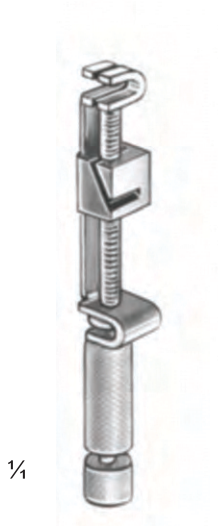

1/4
Tofflemire-Universal
RAS-0,65-2601



1/4
Tofflemire-Senior
RAS-0,65-2602



1/4
Tofflemire-Junior
RAS-0,65-2603



1/4
Fig.1
Nystrom
left
RAS-0,65-2604



1/4
Fig.2
Nystrom
right
RAS-0,65-2605



1/4
Ivory 8
RAS-0,65-2606 5 mm
RAS-0,65-2607 6 mm
RAS-0,65-2608 7 mm



1/4
Ivory 8N
RAS-0,65-2609

adjustable



1/4
Didner 8P
RAS-0,65-2610



Ivory
RAS-0,65-2611
Fig. 1



Ivory
RAS-0,65-2612
Fig. 12



Ivory
RAS-0,65-2613
Fig. 12A

MATRIX RETAINERS



Ainsworth
RAS-0,65-2614
16 cm / 6 1/2"



Ainsworth
RAS-0,65-2615
16 cm / 6 1/2"



Ivory
RAS-0,65-2616
15 cm / 6"



Ivory
RAS-0,65-2617
15 cm / 6"



Ivory
RAS-0,65-2618
17 cm / 6 3/4"



Brewer
RAS-0,65-2619
17 cm / 6 3/4"



Stockes
RAS-0,65-2620
17 cm / 6 3/4"

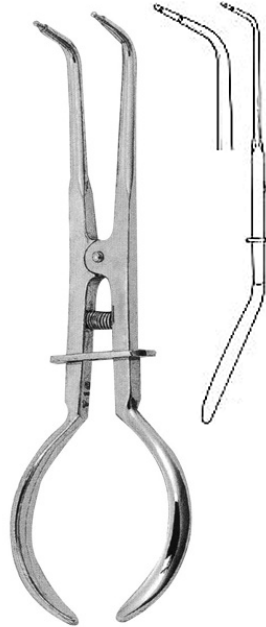

Stockes
RAS-0,65-2621
17 cm / 6 3/4"



Palmer
RAS-0,65-2622
17 cm / 6 3/4"



White
RAS-0,65-2623
17 cm / 6 3/4"



Band Pusher-Mershon
RAS-0,65-2624
14 cm / 5 1/2"

EN Rubber Dam Clamps

DE Knochenfeilen

ES Limes à os

FR Lima para huesos

IT Lima per ossa



RAS-0,65-2626
Fig. 00
Anterior Teeth



RAS-0,65-2627
Fig. 0
Premolars



RAS-0,65-2628
Fig. 1
Premolars



RAS-0,65-2629
Fig. 1A
Premolars



RAS-0,65-2630
Fig. 2
Premolars



RAS-65-2631
Fig. 2A
Premolars



RAS-65-2632
Fig. 2AS
Premolars



RAS-65-2633
Fig. 3
Lower Molars



RAS-65-2634
Fig. 4
Upper Molars



RAS-65-2635
Fig. 5
Upper Molars



RAS-0,65-2636
Fig. 6
Anterior Teeth



RAS-0,65-2637
Fig. 7
Lower Molars



RAS-0,65-2638
Fig. 7A
Lower Molars



RAS-0,65-2639
Fig. 8
Upper Molars



RAS-0,65-2640
Fig. 8A
Molars General



RAS-0,65-2641
Fig. 9
Anterior Teeth



RAS-0,65-2642
Fig. 9S
Anterior Teeth



RAS-0,65-2643
Fig. 10
Molars General



RAS-0,65-2644
Fig. 11
Molars General



RAS-0,65-2645
Fig. 24
Molars General



RAS-0,65-2646
Fig. 25
Molars General



RAS-0,65-2647
Fig. 26
Lower Molars



RAS-0,65-2648
Fig. 26N
Molars General



RAS-0,65-2649
Fig. 27
Molars General



RAS-0,65-2650
Fig. 27N
Premolars



RAS-0,65-2651
Fig. 28
Lower Molars



RAS-0,65-2652
Fig. 29
Lower Molars



RAS-0,65-2653
Fig. 30
Upper Molars



RAS-0,65-2654
Fig. 31
Upper Molars



RAS-0,65-2655
Fig. 56
Molars General



RAS-0,65-2656
Fig. 56S
Molars General



RAS-0,65-2657
Fig. 201
Upper Molars



RAS-0,65-2658
Fig. 205
Upper Molars



RAS-0,65-2659
Fig. 212
Anterior Teeth



RAS-0,65-2660
Fig. 212SA
Anterior Teeth



RAS-0,65-2661
Fig. W2
Premolars



RAS-0,65-2662
Fig. W3
Lower Molars



RAS-0,65-2663
Fig. W4
Upper Molars



RAS-0,65-2664
Fig. W7
Lower Molars



RAS-0,65-2665 Frame - Child
13 cm/5"
RAS-0,65-2666 Frame - Adult
15 cm/6"



RAS-0,65-2667
Beerendonk

RAS-0,65-2668
Boley



Iwanson
One side graugation
RAS-0,65-2669 Metal
RAS-0,65-2670 Wax

Double side graugation
RAS-0,65-2671 Metal
RAS-65-2672 Wax

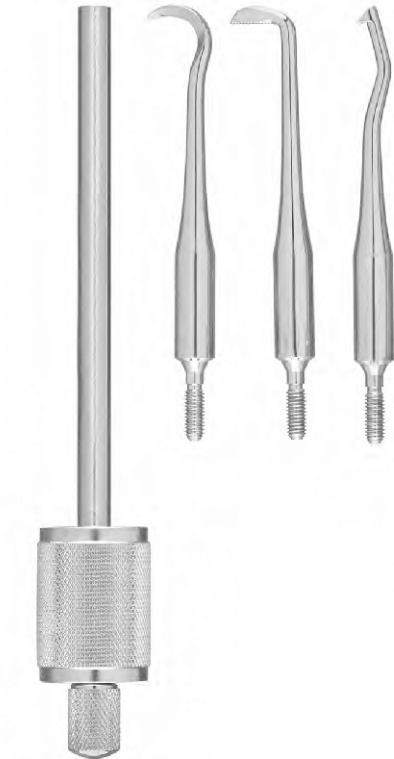

RAS-65-2673
Morrel
Crown Remover



RAS-65-2674
Crown Remover
Manual



RAS-65-2675
Crown Remover
Manual



RAS-65-2676
Crown Remover
Automatic



RAS-65-2677
Crown Remover
Automatic

- EN** Hemostatic Forceps
- DE** Arterienklemmen
- ES** Pincas hemostaticas
- FR** Pinzashemostaticas
- IT** Pinze emostatiche

Page 126 to 132



EN	Artery Forceps
DE	Arterienklemmen
ES	Pinzas hemostáticas
FR	Forceps de l'artère
IT	Arteria Forcipe

ARTERY FORCEPS



Halsted-Mosquito



RAS-66-2701
12.5 cm/5"



RAS-66-2702
14.5 cm/5 3/4"



RAS-66-2703
14 cm/5 1/2"



RAS-66-2704
12.5 cm/5"
1:2



RAS-66-2705
14.5 cm/5 3/4"
1:2



RAS-66-2706
12 cm/4 3/4"
1:2



RAS-66-2707
14 cm/4 1/2"
1:2



Micro-Mosquito



RAS-66-2708
10 cm/4"



RAS-66-2709
12 cm/4 3/4"



RAS-66-2710
9.5 cm/3 1/2"



RAS-66-2711
11.5 cm/4 1/2"



JM-66-2712
10 cm/4"
1:2



JM-66-2713
12 cm/4 3/4"
1:2



JM-66-2714
10 cm/4"
1:2



JM-66-2715
12 cm/4 3/4"
1:2



Halsted-Mosquito

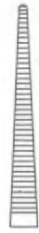

RAS-66-2716
18 cm/7"



RAS-66-2717
18 cm/7"



RAS-66-2718
18 cm/7"
1:2



RAS-66-2719
18 cm/7"
1:2

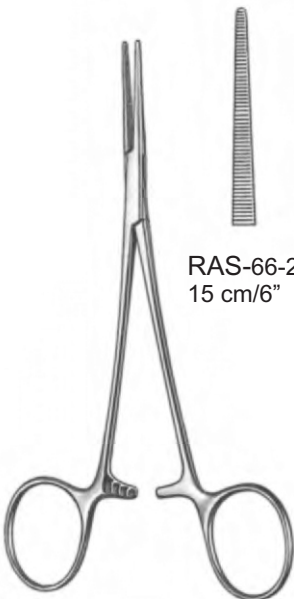

Leriche



RAS-66-2720
15 cm/6"

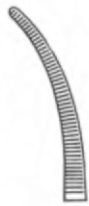

RAS-66-2721
15 cm/6"



RAS-66-2722
15 cm/6"
1:2



RAS-66-2723
15 cm/6"
1:2



RAS-66-2724
15 cm/6"



RAS-66-2725
15 cm/6"

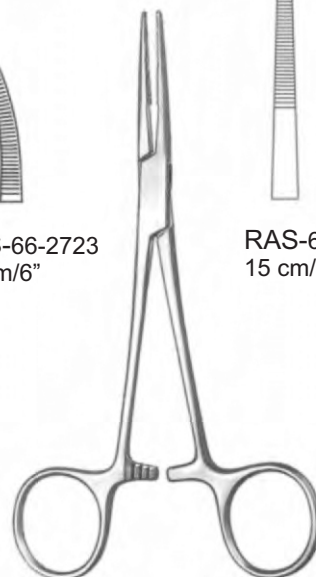

Kelly

EN	Artery Forceps
DE	Arterienklemmen
ES	Pinzas hemostáticas
FR	Forceps de l'artère
IT	Arteria Forcipe

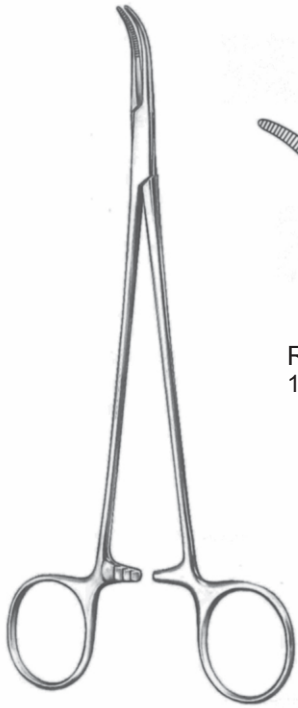

Mixer-Baby



RAS-66-2726
18.5 cm/7 1/4"



Pean



RAS-66-2727
14.5 cm/5 3/4"



RAS-66-2728
16 cm/6 1/4"



Pean



RAS-66-2729
13 cm/5"



RAS-66-2730
14 cm/5 1/2"



RAS-66-2731
17 cm/6 3/4"



RAS-66-2732
13 cm/5"



RAS-66-2733
14 cm/5 1/2"



RAS-66-2734
17 cm/6 3/4"

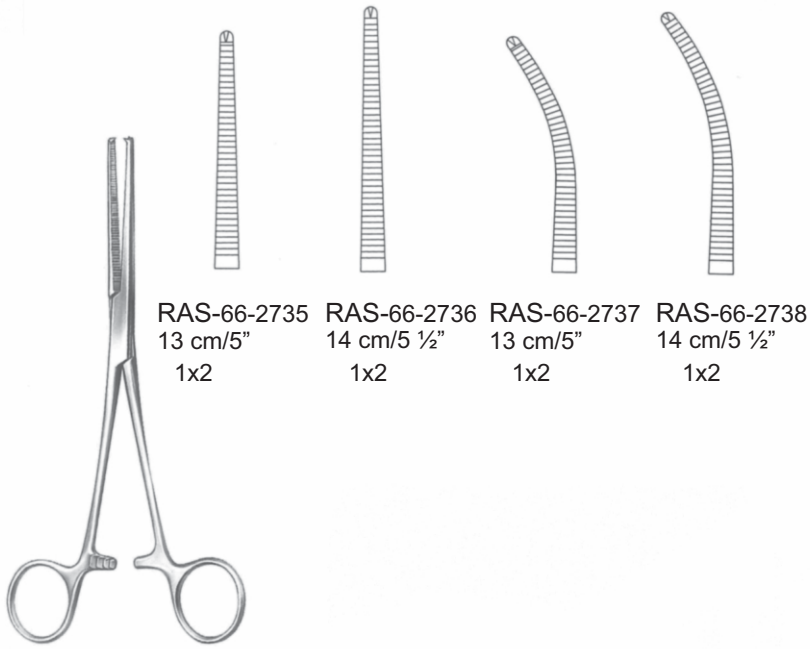

RAS-66-2735 13 cm/5" 1x2
 RAS-66-2736 14 cm/5 1/2" 1x2
 RAS-66-2737 13 cm/5" 1x2
 RAS-66-2738 14 cm/5 1/2" 1x2

Kocher

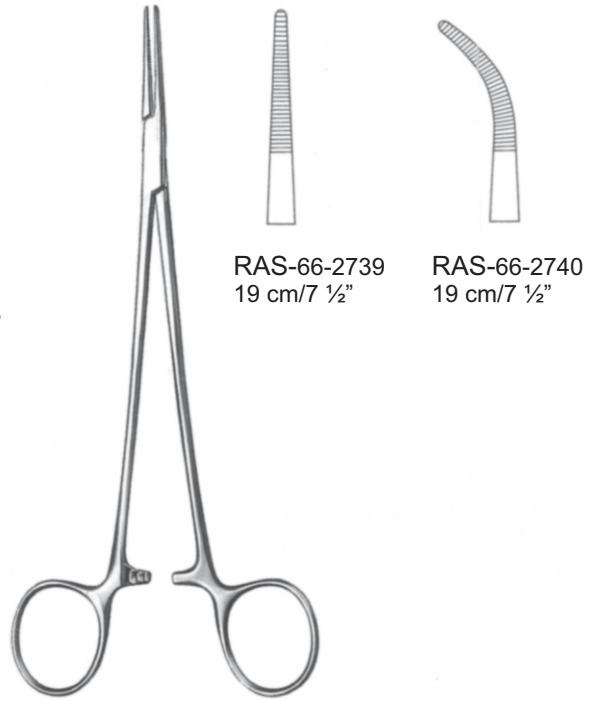

RAS-66-2739 19 cm/7 1/2"
 RAS-66-2740 19 cm/7 1/2"

Adson

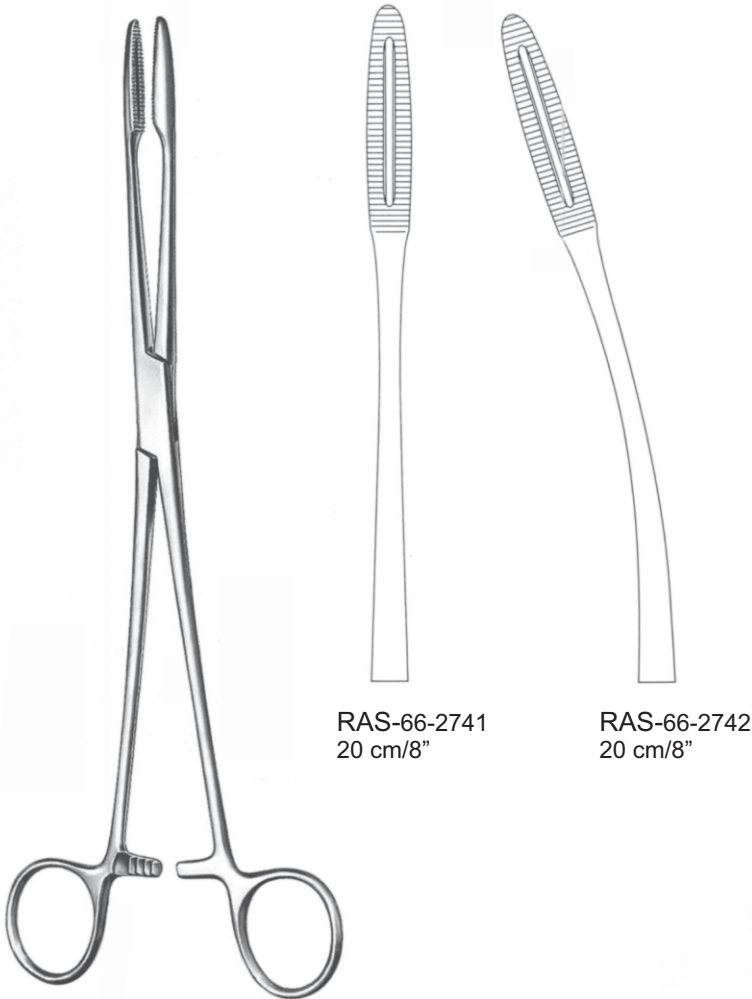

RAS-66-2741 20 cm/8"

RAS-66-2742 20 cm/8"

Gross-Maier



ATRAUMA

RAS-66-2743 12.5 cm/5"
 RAS-66-2744 12.5 cm/5"

DeBakey-Mosquito

EN	Artery Forceps
DE	Arterienklemmen
ES	Pinzas hemostáticas
FR	Forceps de l'artère
IT	Arteria Forcipe



Babcock

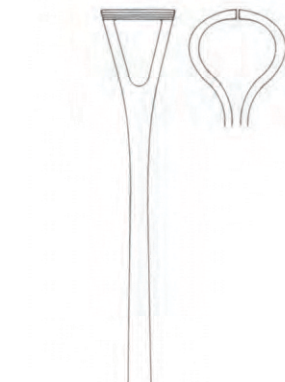

- RAS-66-2745 16 cm/6 1/4"
- RAS-66-2746 18 cm/7"
- RAS-66-2747 20 cm/7 7/8"
- RAS-66-2748 24 cm/9 1/2"



Babcock



RAS-66-2749C
16 cm/6 1/2"



ATRAUMA

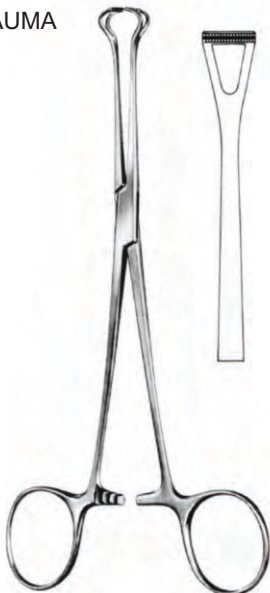

BABCOCK
RAS-66-2750
16 cm/9 1/4"

ATRAUMA

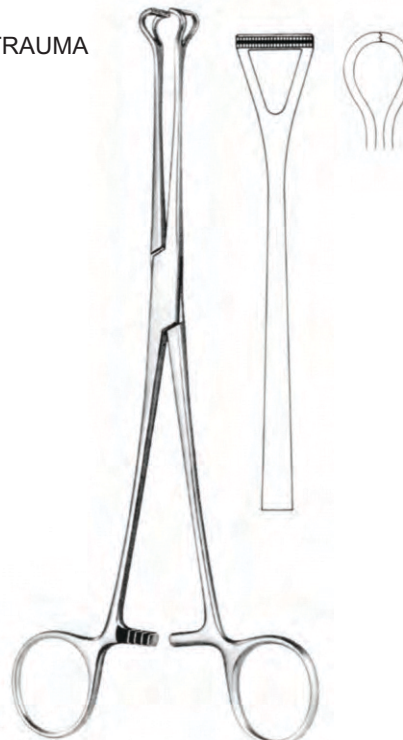

BABCOCK
RAS-66-2751
20.5 cm/8 1/8"



Allis



RAS-66-2752
15.5 cm/6"
4:5



RAS-66-2753
15.5 cm/6"
5:6



RAS-66-2754
19 cm/7 1/2"
5:6



Allis-Baby



RAS-66-2755
12 cm/5"
4:5

EN	Artery Forceps
DE	Arterienklemmen
ES	Pinzas hemostáticas
FR	Forceps de l'artère
IT	Arteria Forcipe

ATRAUMA

RAS-66-2756 RAS-66-2757
16 cm/6 1/2" 20 cm/8"

Allis

- EN** Towel Clamps
- DE** Handtuchklammern
- ES** Abrazaderas de toalla
- FR** Pinces à serviettes
- IT** Morsetti per asciugamano

Page 133 to 134

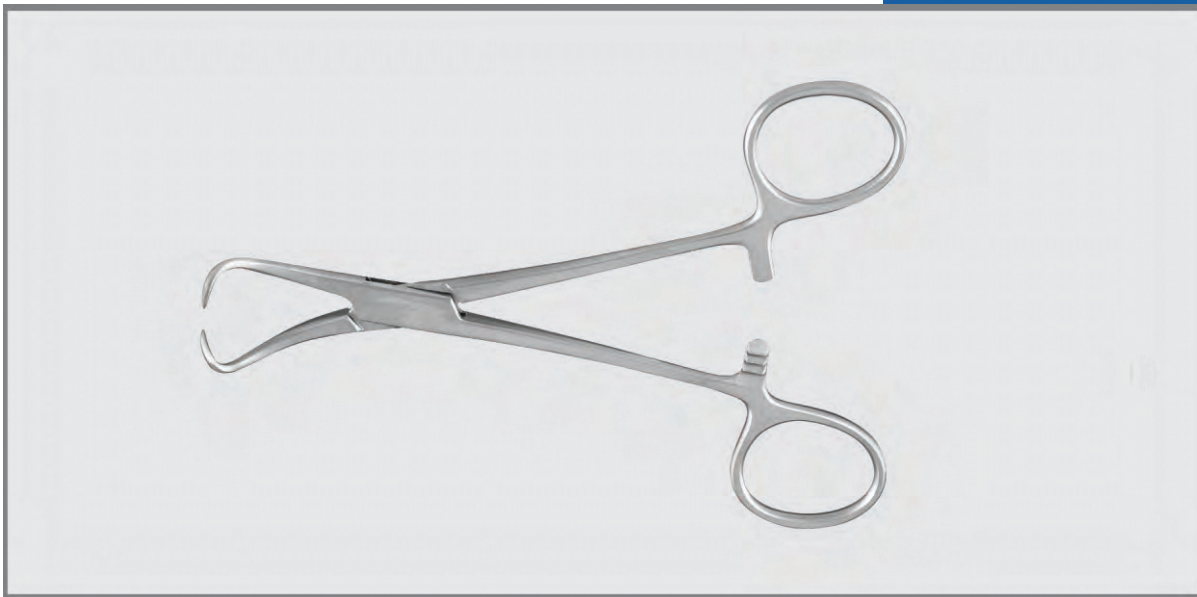

EN	Towel Clamps
DE	Handtuchklammern
ES	Abrazaderas de toalla
FR	Pinces à serviettes
IT	Morsetti per asciugamano

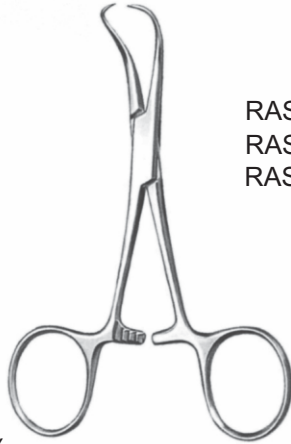

1/2

Backhaus

RAS-67-2801 9 cm/3 1/2"
 RAS-67-2802 11.5 cm/4 1/2"
 RAS-67-2803 13 cm/5"



1/2

for paper clothes

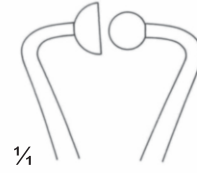

1/4

RAS-67-2804
 11.5 cm/4 1/2"

RAS-67-2805
 14 cm/5 1/2"



1/2

Peers-Bertram
 RAS-67-2806
 14.5 cm/5 3/4"

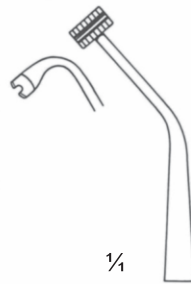

1/4

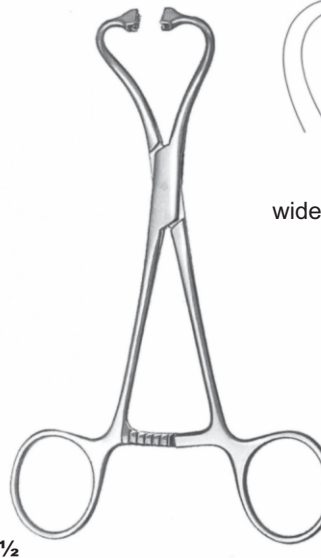

1/2

Peers-Bertram modif.
 RAS-67-2807
 15.5 cm/6"

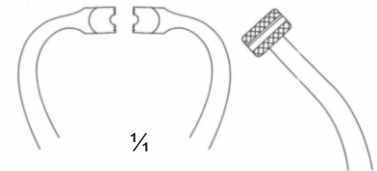

1/4

wide jaw for tube fixation



¼
RAS-67-2808
10.5 cm/4"

RAS-67-2809
13.5 cm/5 ¼"



½
Schadel
RAS-67-2810
8.5 cm/3 ½"
sharp



½
Jones
sharp

RAS-67-2811
8.5 cm/3 ¼"

- EN** Needle Holders
- DE** Nadelhalter
- ES** Porte-aiguilles
- FR** Porta-agujcs
- IT** Port' aghi

Page 135 to 143



EN	Needle Holders
DE	Nadelhalter
ES	Porta agujas
FR	Porte-aiguilles
IT	Porta-aghi

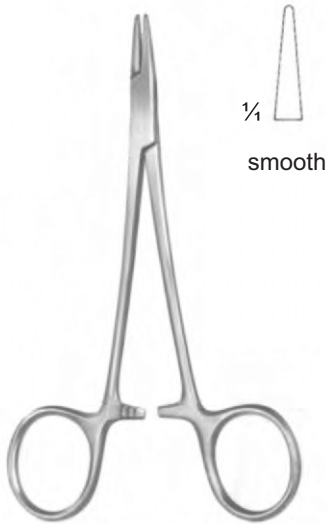

Webster
RAS-68-2901
13 cm/5 1/8"

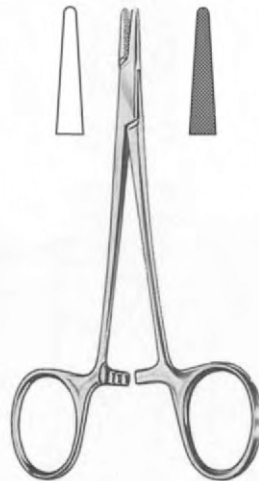

Halsey
RAS-68-2902 13 cm/5 1/8" Plain
RAS-68-2903 13 cm/5 1/8" Serrated



Derf
RAS-68-2904
12 cm/4 3/4"
one feestrated jaw



Crile-Wood
RAS-68-2905
15 cm/5 7/8"



Crile-Murray
RAS-68-2906
15 cm/5 7/8"
slender pattren

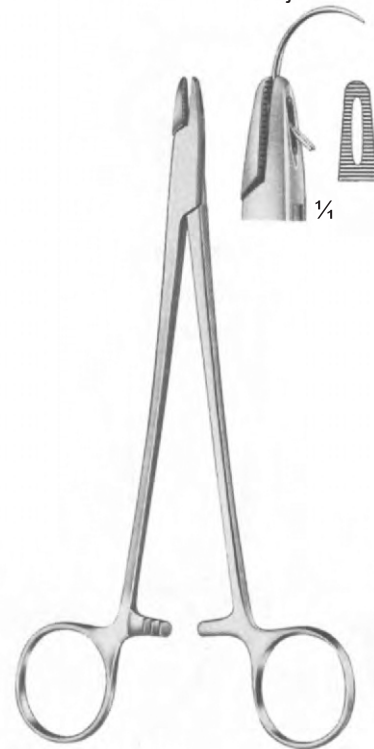

Adson
RAS-68-2907
18 cm/7 1/8"
one fenestreated jaw

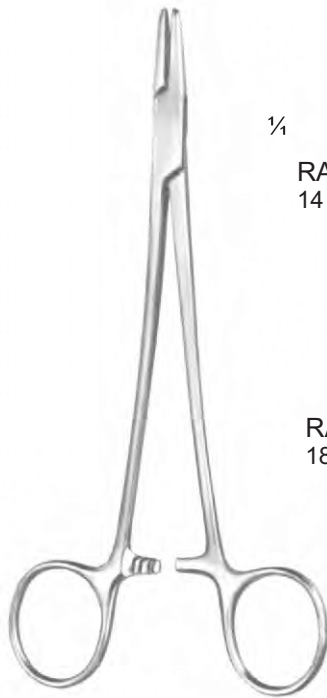

MAYO-HEGAR

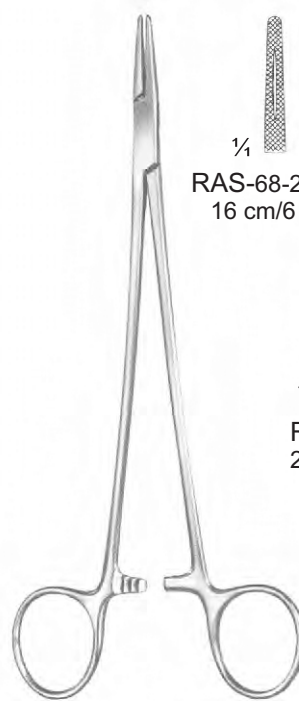
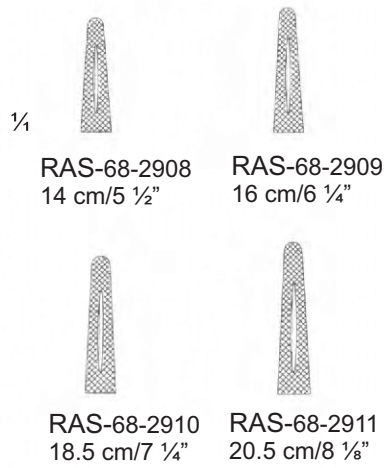

MAYO-HEGAR
slender pattern

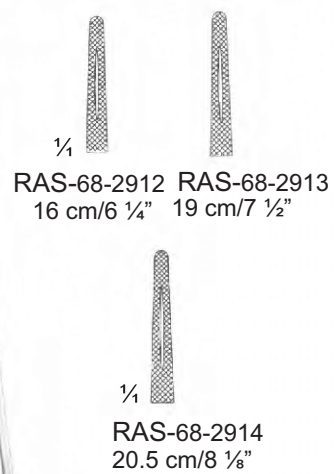

HEGAR-BAUMGARTNER
RAS-68-2915
14 cm/5 1/2"



MATHIEU



MATHIEU
slender pattern

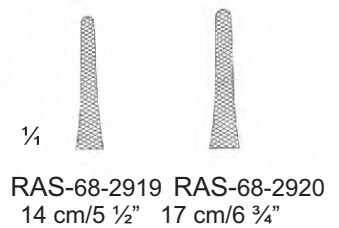

EN Needle Holders

DE Nadelhalter

ES Porta agujas

FR Porte-aiguilles

IT Porta-aghi



Lichtenberg
RAS-68-2921
20 cm/7 $\frac{7}{8}$ "



Toennis
RAS-68-2922
18.5 cm/7 $\frac{1}{4}$ "



Crile
RAS-68-2923
15 cm/5 $\frac{7}{8}$ "

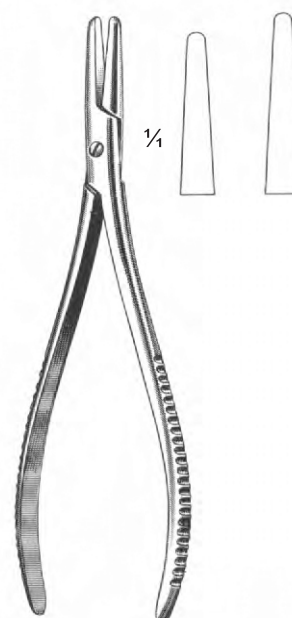

Langenbeck
RAS-68-2924 16 cm/6 $\frac{1}{4}$ "
RAS-68-2925 20 cm/7 $\frac{7}{8}$ "

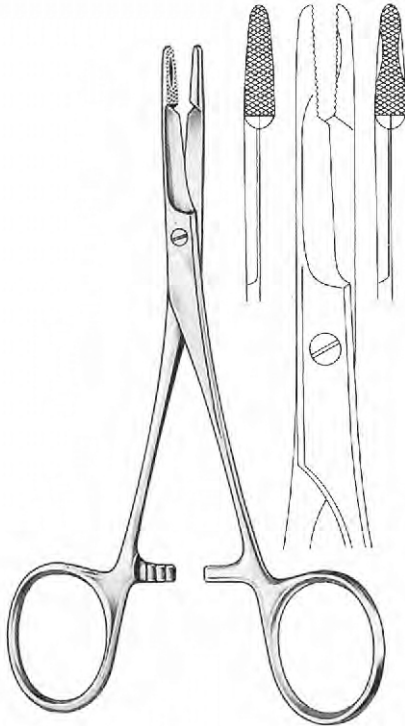

Olsen-Hegar

RAS-68-2926 11 cm/4"

RAS-68-2927 14 cm/5 1/2"

RAS-68-2928 18 cm/7"

RAS-68-2929 19 cm/7 1/2"

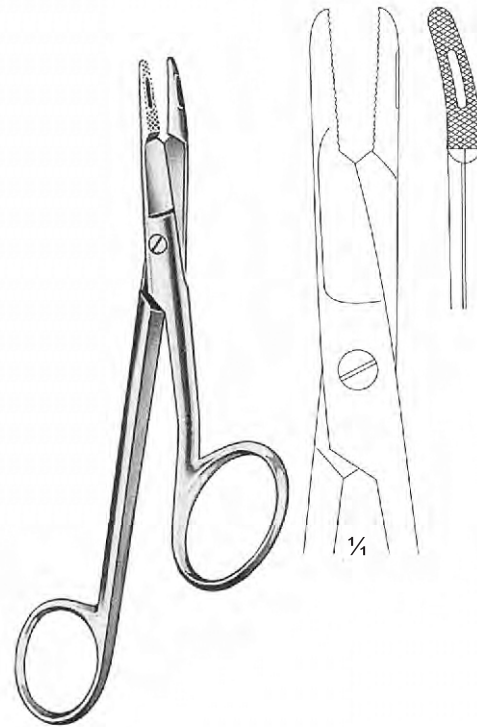

Gillies

RAS-68-2930 Right hand

RAS-68-2931 Left hand
16 cm/6 1/4"

EN	Needle Holders
DE	Nadelhalter
ES	Porta agujas
FR	Porte-aiguilles
IT	Porta-aghi



RAS-68-2932
13 cm/5 1/8"
smooth jaw



RAS-68-2933
13 cm/5 1/8"
0.4 mm

HALSEY

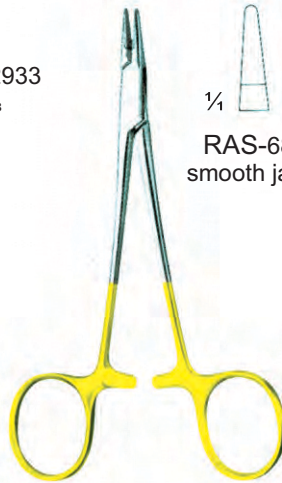

RAS-68-2934
smooth jaw



RAS-68-2935
0.4 mm

WEBSTER
12.5 cm/4 7/8"



0.4 mm

DERF
RAS-68-2936
12 cm/4 3/4"



0.5 mm

Toennis
RAS-68-2937
18 cm/7 1/8"



0.5 mm
RAS-68-2938
18.5 cm/7 1/4"



0.5 mm
RAS-68-2939
20.5 cm/8 1/8"



0.5 mm
RAS-68-2940
23 cm/9"

Langenbeck

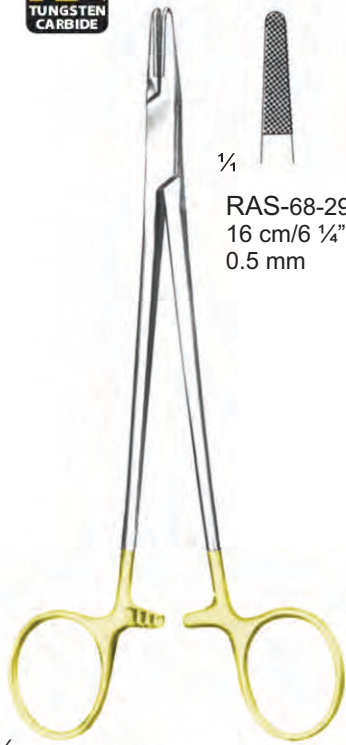

1/2

Mayo-Hegar
standard profile

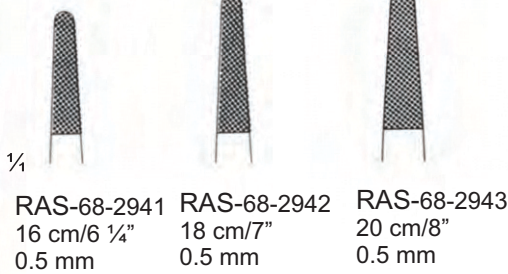

RAS-68-2941 16 cm/6 1/4" 0.5 mm
 RAS-68-2942 18 cm/7" 0.5 mm
 RAS-68-2943 20 cm/8" 0.5 mm



1/2

Debakey
mini profile

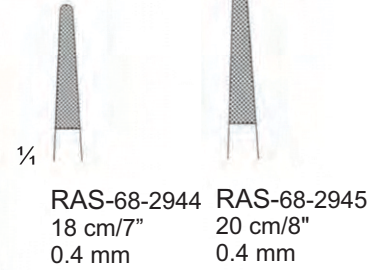

RAS-68-2944 18 cm/7" 0.4 mm
 RAS-68-2945 20 cm/8" 0.4 mm

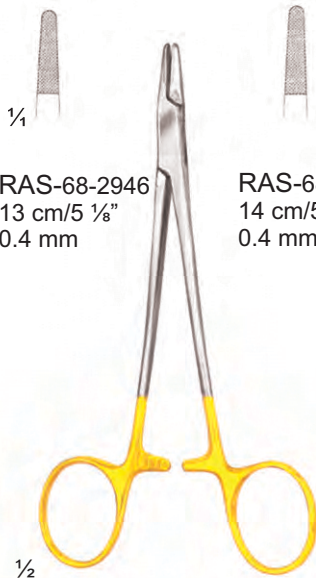

1/2

HEGAR-BAUMGARTNER

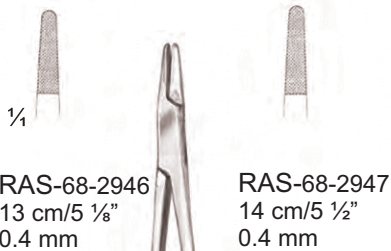

RAS-68-2946 13 cm/5 1/8" 0.4 mm
 RAS-68-2947 14 cm/5 1/2" 0.4 mm

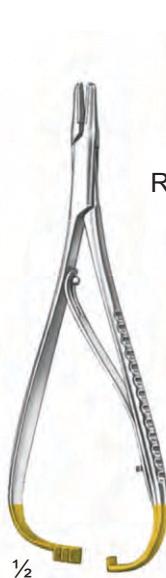

1/2

Mathieu
Standard Profile

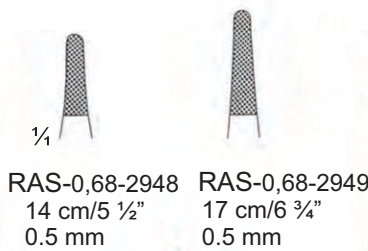

RAS-0,68-2948 14 cm/5 1/2" 0.5 mm
 RAS-0,68-2949 17 cm/6 3/4" 0.5 mm



0,68-2950
20 cm/8" 0.5 mm



1/2

Mathieu
Standard Profile

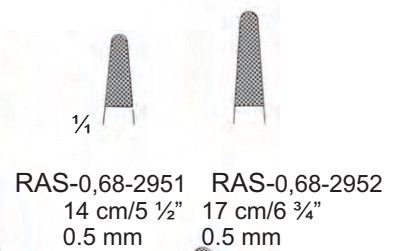

RAS-0,68-2951 14 cm/5 1/2" 0.5 mm
 RAS-0,68-2952 17 cm/6 3/4" 0.5 mm

RAS-0,68-2953
20 cm/8" 0.5 mm

EN	Needle Holders
DE	Nadelhalter
ES	Porta agujas
FR	Porte-aiguilles
IT	Porta-aghi



Mathieu



RAS-0,68-2954 17 cm/6 3/4" 0.5 mm
 RAS-0,68-2955 20 cm/8" 0.5 mm
 RAS-0,68-2956 23 cm/9" 0.5 mm

with interior ratchet
 standard profile



Lichtenberg
 RAS-0,68-2957
 20 cm/7 7/8"

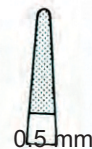

Zweifel

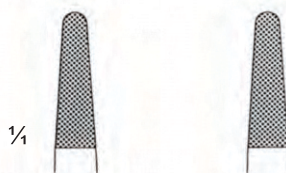

RAS-0,68-2958 20.5 cm/8" 0.5 mm
 RAS-0,68-2959 23 cm/9" 0.5 mm

with hinged rehet
 Standard Profile

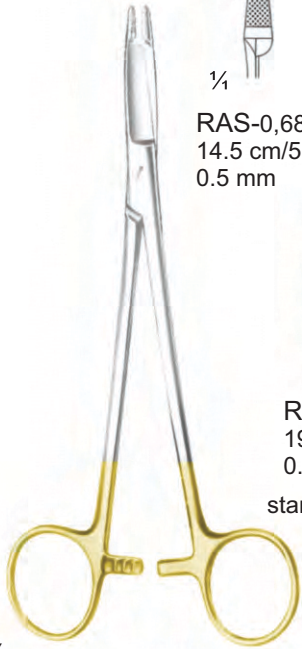
1/2

RAS-0,68-2960
14.5 cm/5 3/4"
0.5 mm

RAS-0,68-2961
17 cm/6 3/4"
0.5 mm

RAS-0,68-2962
19 cm/9 1/2"
0.5 mm
standard profile

Olsen-Hegar

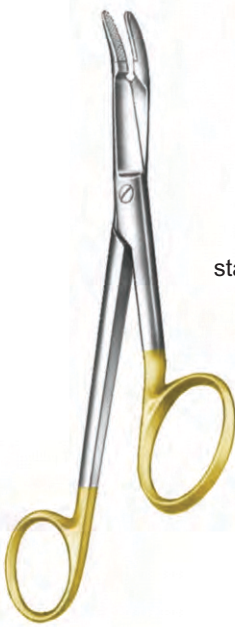

1/4

RAS-0,68-2963
16 cm/6 1/4"
0.5 mm
standard profile

Gillies



1/4

RAS-0,68-2964
11 cm/4 1/4"
smooth jaw

Foster-Gillies



1/4

RAS-0,68-2965
15 cm/6"
0.4 mm
mini profile

Gillies-Mini

EN	Needle Holders
DE	Nadelhalter
ES	Porta agujas
FR	Porte-aiguilles
IT	Porta-aghi



1/4
RAS-0,68-2966
12 cm/4 3/4"
with lock



1/4
RAS-68-2967
12 cm/4 3/4"
with lock

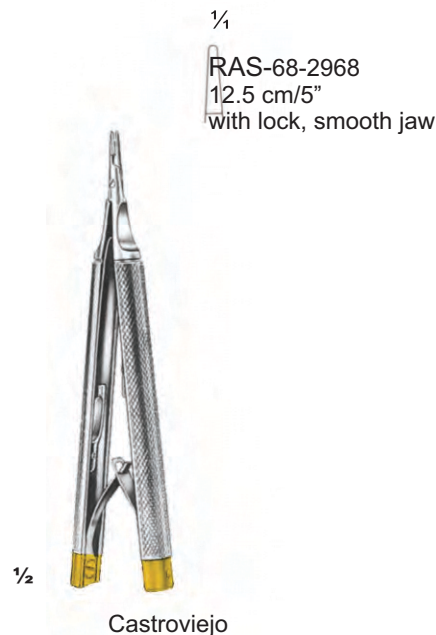

1/4
RAS-68-2968
12.5 cm/5"
with lock, smooth jaw



RAS-68-2969
14.5 cm/5 3/4"
with lock
micro profile
0.3 mm



RAS-68-2970
14.5 cm/5 3/4"
with lock
micro profile
0.3 mm



RAS-68-2971
14.5 cm/5 3/4"
smooth jaw
0.3 mm



RAS-68-2972
18 cm/7"
with lock
micro profile
0.3 mm



RAS-68-2973
21.5 cm/8 1/2"
with lock
micro profile
0.3 mm



RAS-68-2974
14.5 cm/5 3/4"
smooth jaw



RAS-68-2975
18 cm/7"
with lock
micro profile
0.3 mm



RAS-68-2976
21.5 cm/8 1/2"
with lock
micro profile
0.3 mm

- EN** Retractors
- DE** Wundhaken
- ES** Ecarteurs
- FR** Separadores
- IT** Divaricatori

Page 144 to 148



EN	Retractors
DE	Wundhaken
ES	Ecarteurs
FR	Separadores
IT	Divaricatori

RETRACTORS



Fig. 2 = 30 x 10 mm
Fig. 1 = 26 x 10 mm

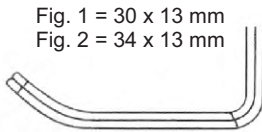

Fig. 1 = 30 x 13 mm
Fig. 2 = 34 x 13 mm

FARABEU
RAS-69-3001
12 cm/4 3/4"
Fig. 1 - 2



ROUX
RAS-69-3002
Set complete, Fig. 1- 3

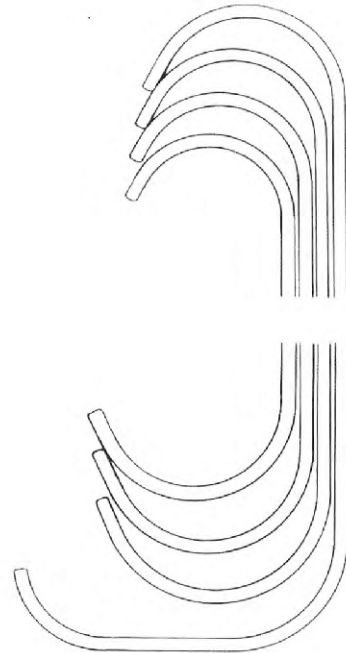
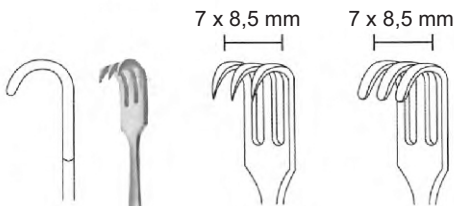
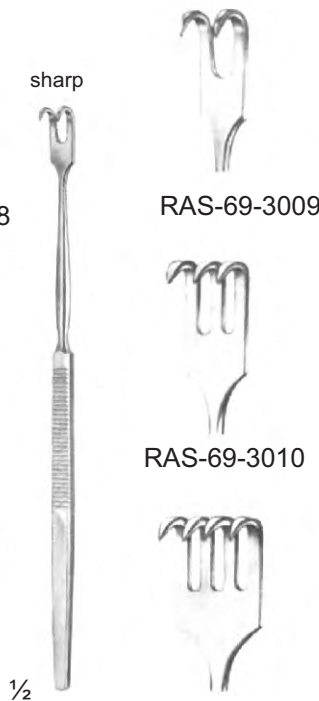

Fig. 1	14 cm/5 1/2"	RAS-69-3003	24 x 20 / 30 x 28
Fig. 2	15 cm/6"	RAS-69-3004	29 x 26 / 36 x 36
Fig. 3	17 cm/6 3/4"	RAS-69-3005	23 x 29 / 38 x 43
Fig. 4	18 cm/7"	RAS-69-3006	29 x 24 / 45 x 28



RAS-69-3007 sharp
RAS-69-3008 blunt

SENN
17 cm/6 3/4"



16 cm/6 1/4" JM-69-3011

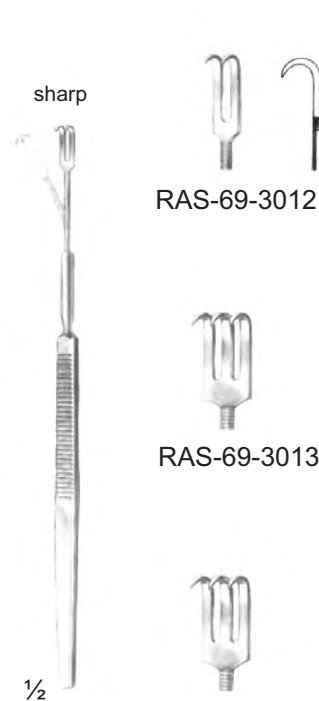

16 cm/6 1/4" JM-69-3014

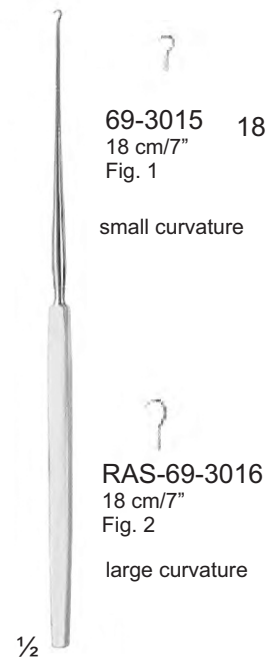

GILLIES
18 cm/7"

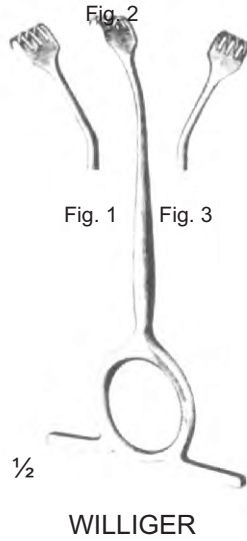
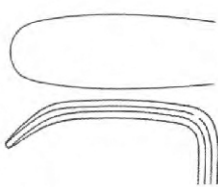

Fig. 1 RAS-69-3021 RAS-69-3024
 Fig. 2 RAS-69-3022 RAS-69-3025
 Fig. 3 RAS-69-3023 RAS-69-3026

STRANDELL-STILLE
 19, cm/7 1/2"

VOLKMANN
 21,5 cm/8 1/2"



RAS-69-3027
 30x 11 mm

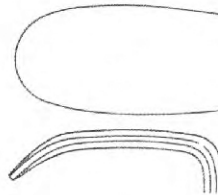

RAS-69-3029
 30x 16 mm

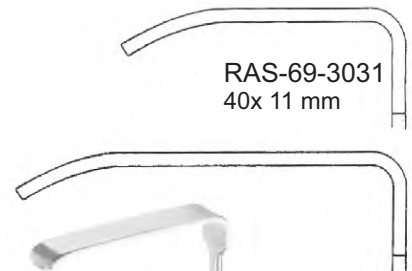

RAS-69-3031
 40x 11 mm

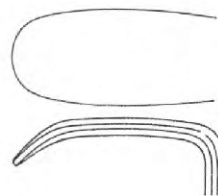

RAS-69-3028
 30x 14 mm

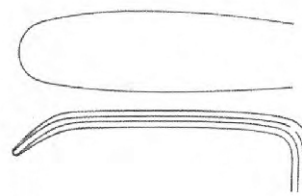

RAS-69-3030
 40x 11 mm

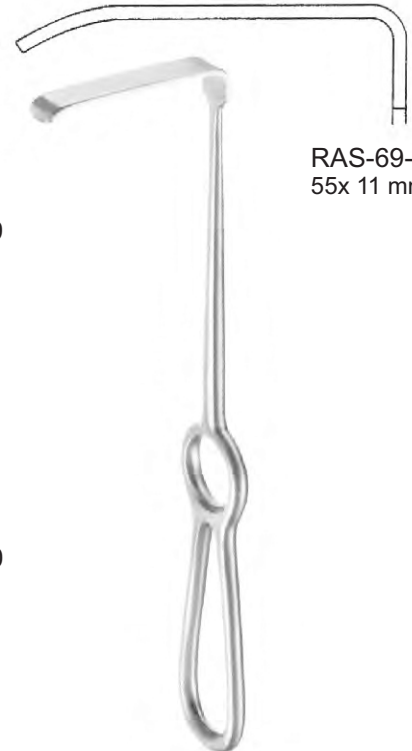

RAS-69-3032
 55x 11 mm

LANGENBECK
 22 cm/8 3/4"

KOCHER-LANGENBECK
 22 cm/8 1/2"

EN	Cheek retractors
DE	Wangenhalter
ES	Ecarteurs des joues
FR	Separatori per guancia
IT	Separadores para mejillas

RETRACTORS



JMDDELDORPF

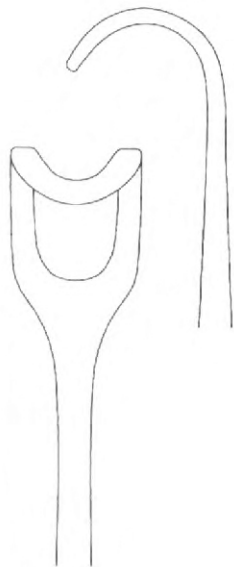

RAS-69-3033
21,5 cm/8 1/2"
14 x 17 mm

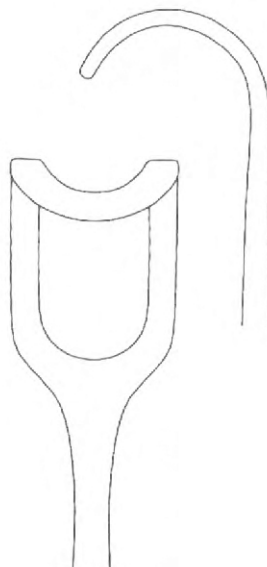

RAS-69-3034
22 cm/8 3/4"
20 x 22 mm



KOCHER LANGENBECK
RAS-69-3035
21 cm/8 1/4"
23 x 8 mm



WARD
RAS-69-3036
15,5 cm/6"



BOWDLER=HENRY
RAS-69-3037
16 cm/6 1/4"



KAY (AUSTIN)
RAS-69-3038

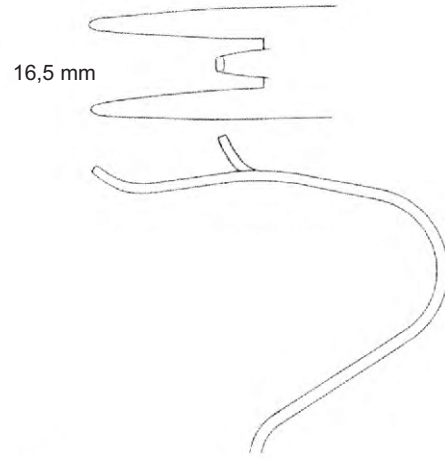
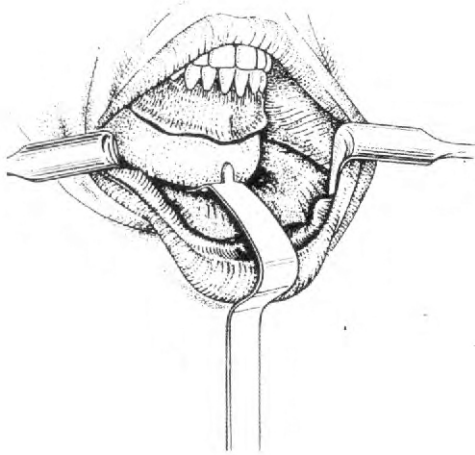

OBWEGESER
RAS-69-3039
16 cm/6 1/4"

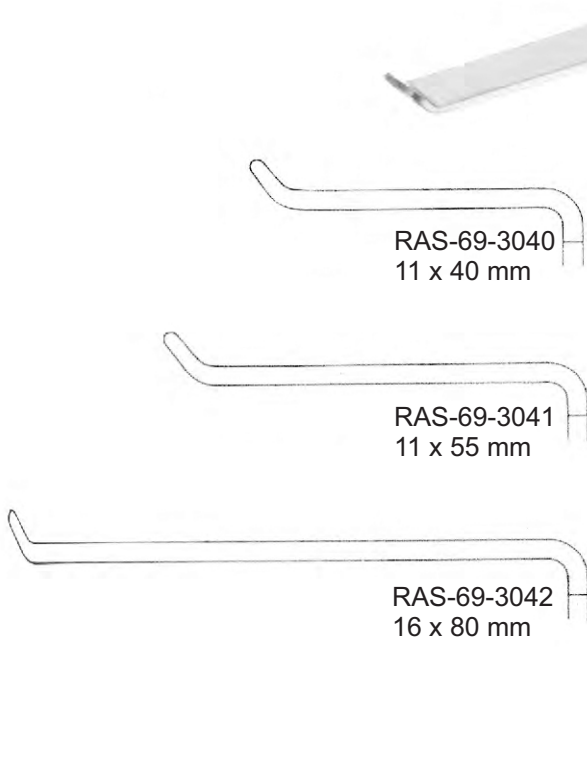

OBWEGESER
21,5 cm/8 1/2"



RAS-69-3043
30 x 9/12 mm

RAS-69-3044
45 x 9/12 mm

RAS-69-3045
60 x 9/12 mm

OBWEGESER

EN	Cheek retractors
DE	Wangenhalter
ES	Ecarteurs des joues
FR	Separatori per guancia
IT	Separadores para mejillas

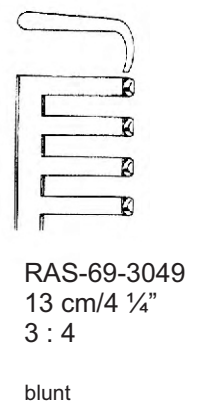
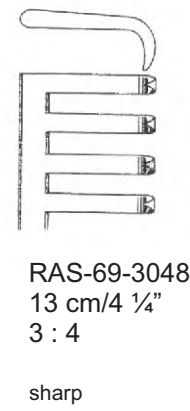
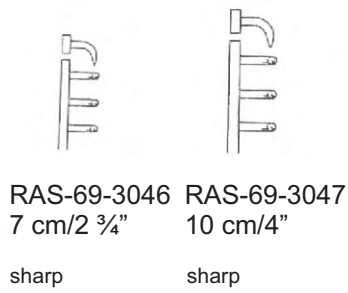

- EN** Mouth and Tongue
- DE** Mund und Zunge
- ES** Boca y la lengua
- FR** Bouche et langue
- IT** Bocca e la lingua

Page 149 to 152



EN Mouth gags

DE Mundsperrer

ES Ouvre-bouche

FR Abrebocas

IT Apribocca



DOYEN-JANSEN (MOLT)
 RAS-70-3100 9 cm/3 1/2"
 RAS-70-3101 11 cm/4 1/2"
 RAS-70-3102 14 cm/5 1/2"



DENHARDT
 RAS-70-3103
 12 cm/5"



HEISTER
 RAS-70-3104
 13 cm/5 1/4"



ROSIER-KOENIG
 16 cm/6 1/4" RAS-70-3105
 19 cm/7 1/2" RAS-70-3106



JENNINGS
 9 cm/3 1/2" RAS-70-3107
 11 cm/4 1/2" RAS-70-3108
 13 cm/5" RAS-70-3109
 15 cm/6" RAS-70-3110

24 x 27 mm



COLLIN
 RAS-70-3111
 16 cm/6 1/2"



YOUNG
 RAS-70-3112
 16 cm/6 1/2"

70-3113

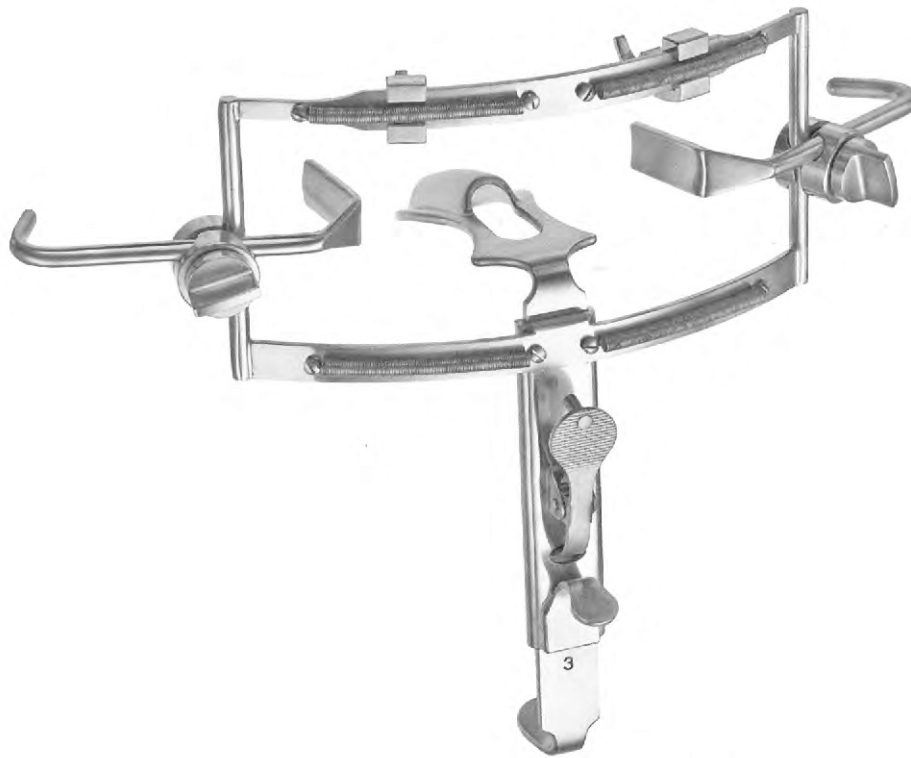

complete with frame,
3 tongue depressors,
2 tooth plates

DINGMANN
RAS-70-3114
14,5 cm/5 ¾"



65 x 25 mm

RAS-70-3115
13,5 cm/5 ¼"



70 x 29 mm

RAS-70-3116
13,5 cm/5 ¼"

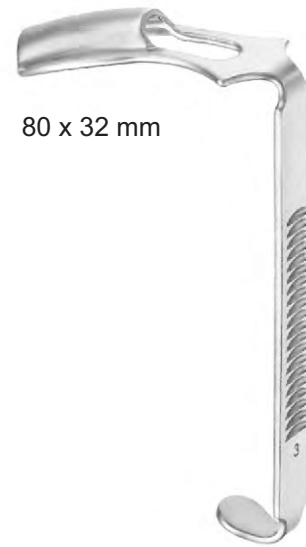

80 x 32 mm

RAS-70-3117
13,5 cm/5 ¼"

EN	Tongue Depressors
DE	Zungenspateln
ES	Abaisse-langue
FR	Abajalengua
IT	Abbassalingua

MOUTH GAGS

19 / 15 mm



RAS-70-3118
16 cm/6 1/4"

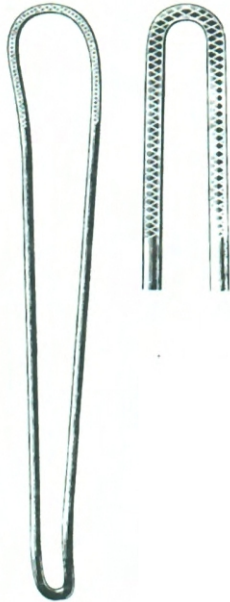

FRENZEL
RAS-70-3119
16,5 cm/6 1/2"



BRUENINGS
RAS-70-3120
19 cm/7 1/2"



BUCHWALD
RAS-70-3121
19 cm/7 1/2"

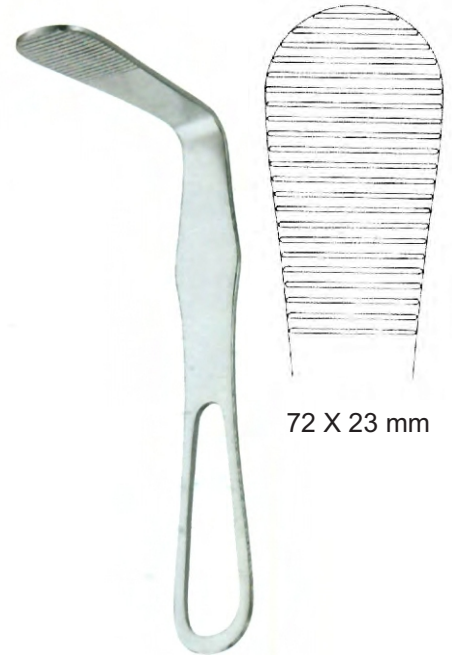

72 X 23 mm

HARTMANN
RAS-70-3122
15 cm/6"



DOYEN

24 / 30 mm

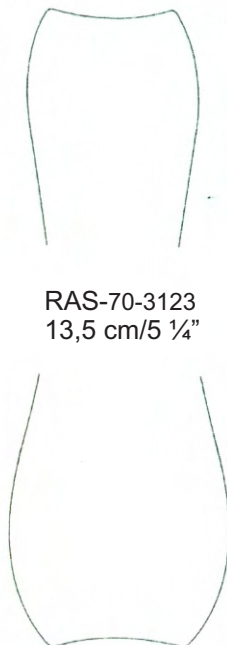

RAS-70-3123
13,5 cm/5 1/4"

30 / 34 mm



RAS-70-3124
16 cm/6 1/4"



WIEDER

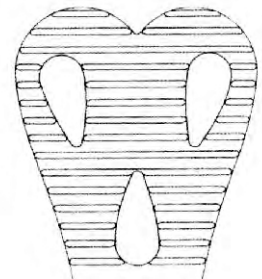

RAS-70-3125
14 cm/5 1/2"
36 mm

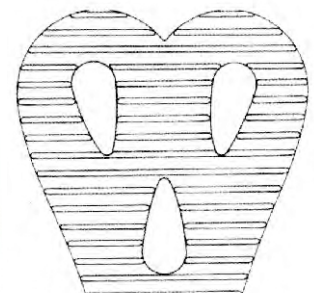

RAS-70-3126
15 cm/6"
43 mm



85 x 24 mm

TOBOLD
RAS-70-3127
14,5 cm/5 ¾"

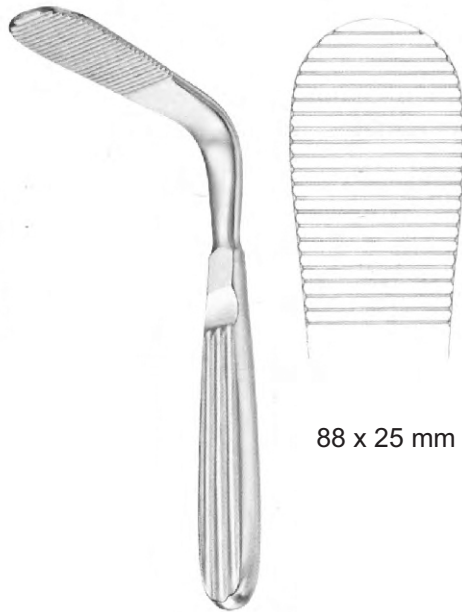

88 x 25 mm

TOBOLD
RAS-70-3128
15 cm/6"



STERNBERG
RAS-70-3129
14 cm/5 ½"



SIMPLEX
RAS-70-3130
11 cm/4 ¼"



CAWOOD-JMNNESOTA
RAS-70-3131
14 cm/5 ½"



CAWOOD-JMNNESOTA
RAS-70-3132
15 cm/6"
20 mm



RAS-70-3133
19 cm/7 ½"

- EN** Scissors
- DE** Schere
- ES** Tijeras
- FR** Les ciseaux
- IT** Forbici

Page 153 to 171



EN	Wire Cutting Scissors
DE	Drahtscheren
ES	Tijeras para alambre
FR	Ciseaux de coupe de fil
IT	Forbici da taglio a filo



1/2
RAS-71-3200
universal
12 cm/4 3/4"

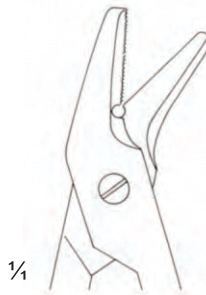

1/4
toothed



1/2
RAS-71-3201 TC
universal
12 cm/4 3/4"

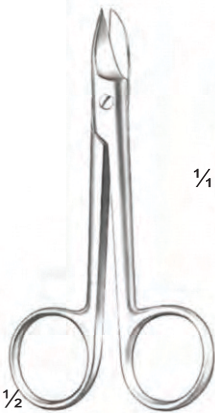

1/2
Beebee
10.5 cm/4 1/8"



1/4
RAS-71-3202
B-002-10 TC



RAS-71-3203
B-003-10 TC

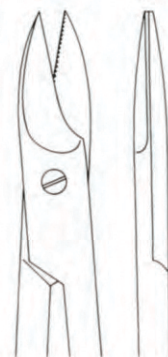

RAS-71-3204
B-004-10 TC



RAS-71-3205
B-005-10 TC

one toothed cutting edge



1/2
Beebee
10.5 cm/4 1/8"







1/2
Standard
14.5 cm/5 3/4

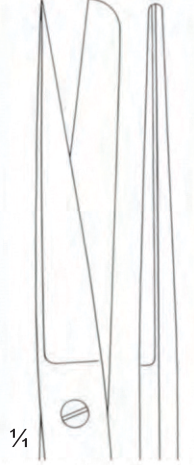

1/4
RAS--71-3206
RAS-71-3207 TC





1/4
RAS-71-3208
RAS-71-3209 TC



1/4
RAS-71-3210
RAS-71-3211 TC



1/2
Standard
14.5 cm/5 3/4

1/2
Standard
14.5 cm/5 3/4



1/4
RAS-71-3212
RAS-71-3213 TC

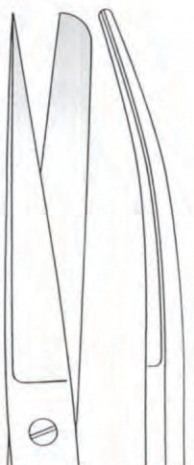

1/4
RAS-71-3214
RAS-71-3215 TC

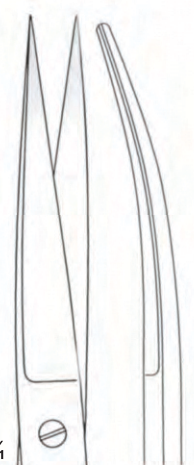

1/4
RAS-71-3216
RAS-71-3217 TC



1/2
Standard
14.5 cm/5 3/4



EN	Operating scissors
DE	Chirurgische scheren
ES	Tijeras quirúrgicas
FR	Ciseaux de fonctionnement
IT	Forbici funzionanti

DELICATE

1/2
14.5 cm/5 3/4"

1/4
RAS-71-3218
RAS-71-3219 TC

1/4
RAS-71-3220
RAS-71-3221 TC

1/4
RAS-71-3222
RAS-71-3223 TC

1/2
14.5 cm/5 3/4"

TC
TUNGSTEN
CARBIDE

1/2
14.5 cm/5 3/4"

1/4
RAS-0,71-3224
RAS-0,71-3225

1/4
RAS-0,71-3226
RAS-0,71-3227

1/4
RAS-0,71-3228
RAS-0,71-3229

1/2
14.5 cm/5 3/4"

TC
TUNGSTEN
CARBIDE



TC
TUNGSTEN
CARBIDE

1/4

RAS-0,71-3230 RAS-0,71-3232
RAS-0,71-3231 RAS-0,71-3233

1/2

Kelly
16 cm/6 1/4"



TC
TUNGSTEN
CARBIDE

1/4

RAS-0,71-3234 RAS-0,71-3236
RAS-0,71-3235 RAS-0,71-3237

1/2

Metzenbaum
11.5 cm/4 1/2"

1/2

Metzenbaum
11.5 cm/4 1/2"

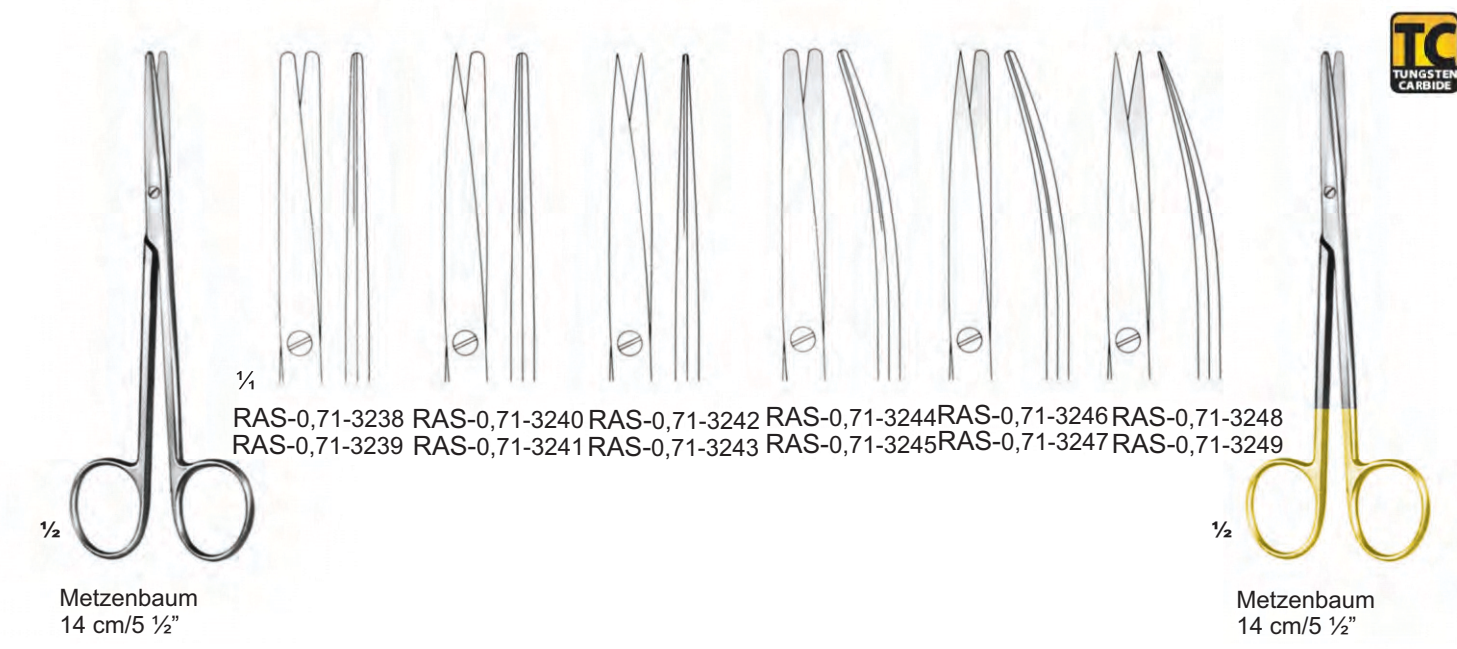

TC
TUNGSTEN
CARBIDE

1/4

RAS-0,71-3238 RAS-0,71-3240 RAS-0,71-3242 RAS-0,71-3244 RAS-0,71-3246 RAS-0,71-3248
RAS-0,71-3239 RAS-0,71-3241 RAS-0,71-3243 RAS-0,71-3245 RAS-0,71-3247 RAS-0,71-3249

1/2

Metzenbaum
14 cm/5 1/2"

1/2

Metzenbaum
14 cm/5 1/2"

EN	Dissecting scissors
DE	Präparierscheren
ES	Tijeras de disección
FR	Ciseaux à dissection
IT	Forbici da dissezione

DELICATE

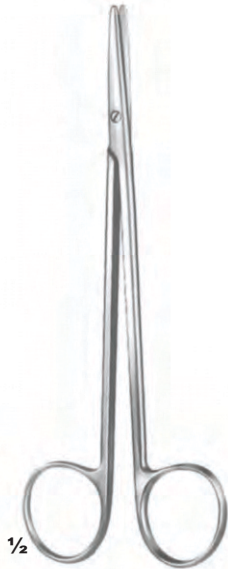

Metzenbaum
15.5 cm/6"

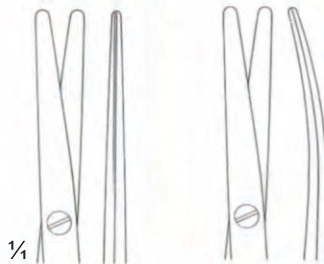

RAS-0,71-3250 RAS-0,71-3252
RAS-0,71-3251 RAS-0,71-3253



Metzenbaum
15.5 cm/6"



Metzenbaum-Nelson
18 cm/7"

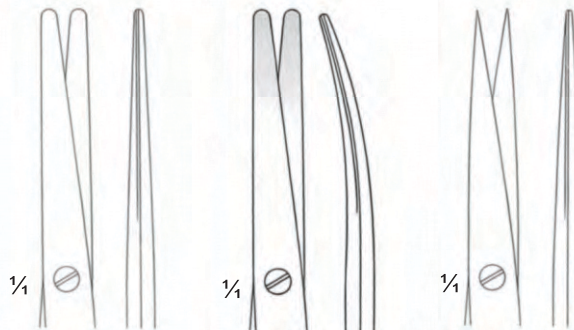

RAS-0,71-3254 RAS-0,71-3256 RAS-0,71-3258
RAS-0,71-3255 RAS-0,71-3257 RAS-0,71-3259



Metzenbaum-Nelson
18 cm/7"



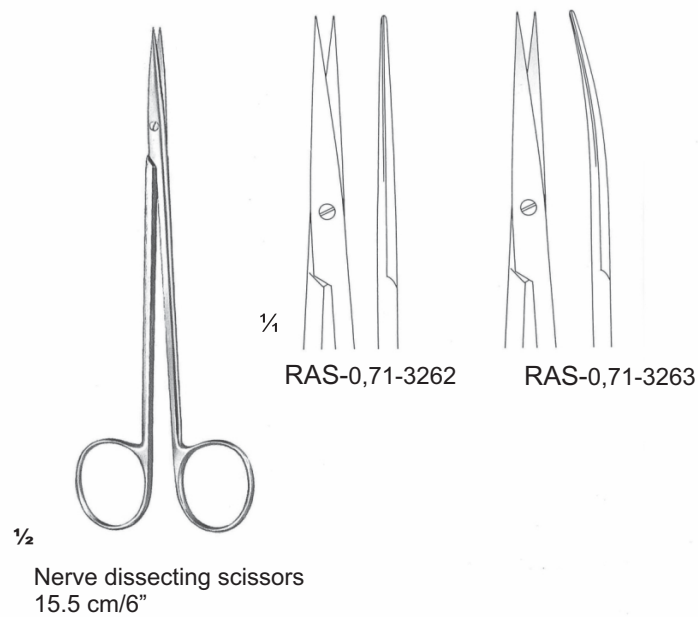
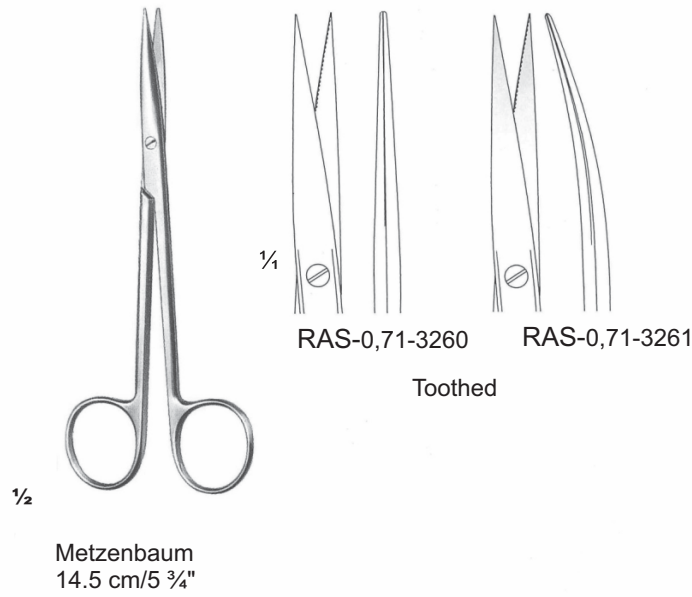

EN	Delicate dissecting scissors
DE	Feine präparierscheren
ES	Tijeras finas de disección
FR	Ciseaux de dissection délicats
IT	Delicate forbici da dissezione



Lexer-Fino
slender pattern
16.5 cm/6 1/2"

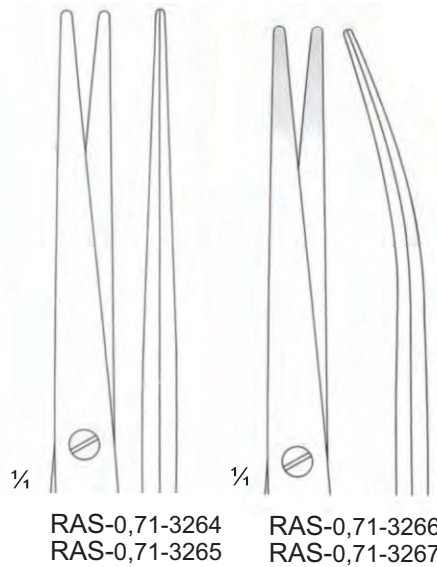

RAS-0,71-3264
RAS-0,71-3265

RAS-0,71-3266
RAS-0,71-3267



Lexer-Fino
slender pattern
16.5 cm/6 1/2"

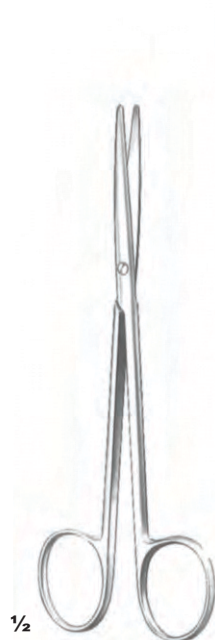

Metzenbaum-Fino
slender pattern
14.5 cm/5 3/4"

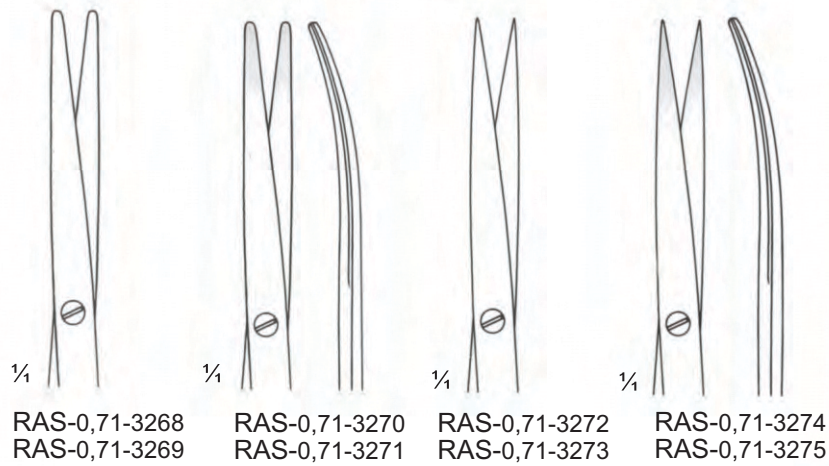

RAS-0,71-3268
RAS-0,71-3269

RAS-0,71-3270
RAS-0,71-3271

RAS-0,71-3272
RAS-0,71-3273

RAS-0,71-3274
RAS-0,71-3275

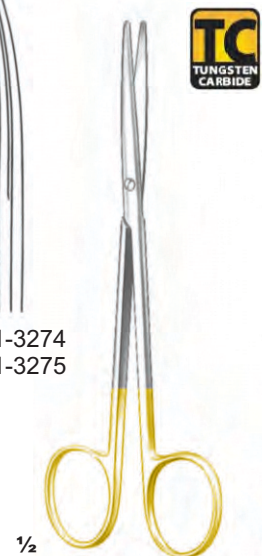

Metzenbaum-Fino
slender pattern
14.5 cm/5 3/4"

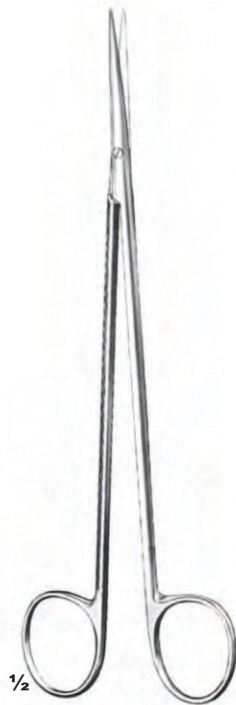

Metzenbaum-Fino
slender pattern
18 cm/7"

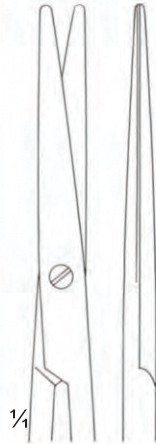

RAS-0,71-3276
RAS-0,71-3277



RAS-0,71-3278
RAS-0,71-3279

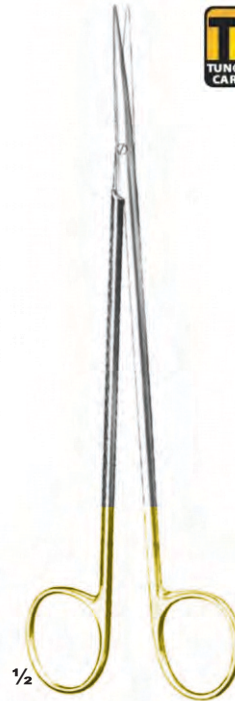

Metzenbaum-Fino
slender pattern
18 cm/7"

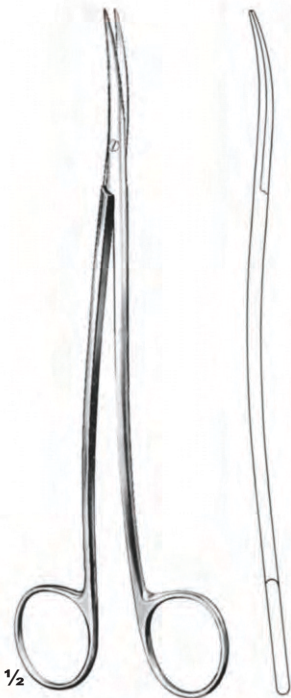

Metzenbaum-Fino
S shaped
18 cm/7"



RAS-0,71-3280
RAS-0,71-3281

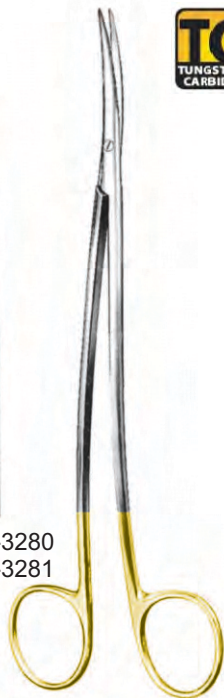

Metzenbaum-Fino
S shaped
18 cm/7"



RAS-0,71-3282
12.5 cm/5"

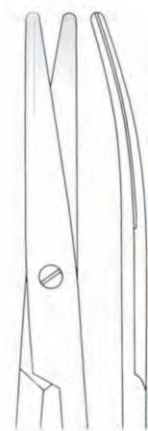

RAS-0,71-3283
18 cm/7"

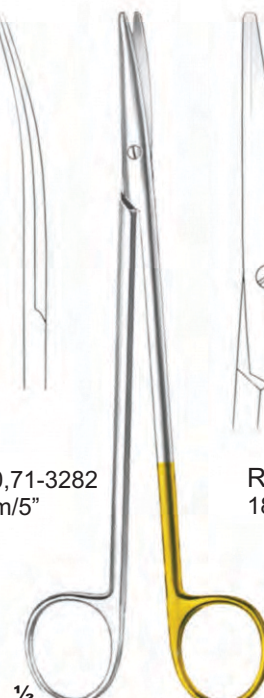

Salzer
fine model for cleft palate

EN Gum scissors, dissecting scissors, operating scissors
DE Zahnfleissscheren, präparierscheren, chirurgische scheren
ES Tijeras para encias, Tijeras de disección, Tijeras quirúrgicas
FR Ciseaux de gomme, ciseaux de dissection, ciseaux de fonctionnement
IT Forbici da masticare, forbici da dissezione, forbici funzionanti

SCISSORS

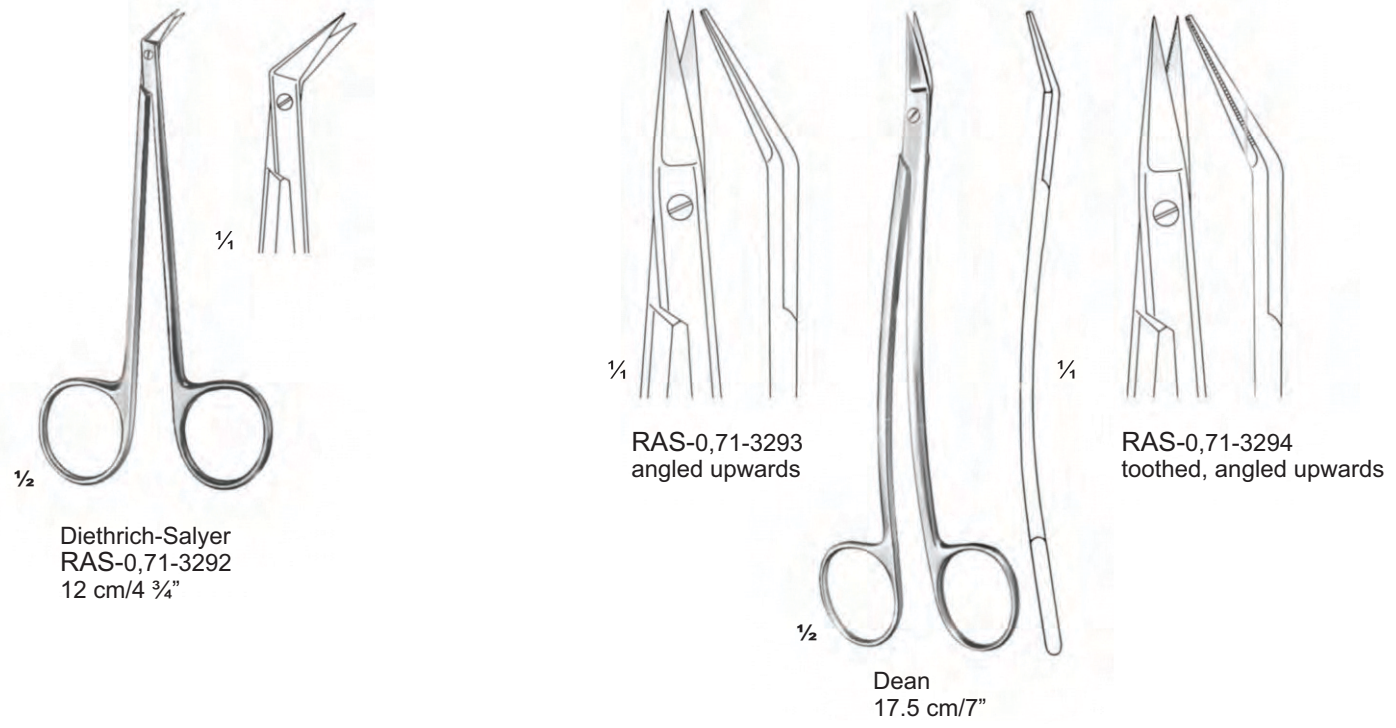



RAS-0,71-3295 RAS-0,71-3297
RAS-0,71-3296 RAS-0,71-3298

GOLDMANN-FOX
13 cm/5 1/8"

GOLDMANN-FOX
13 cm/5 1/8"

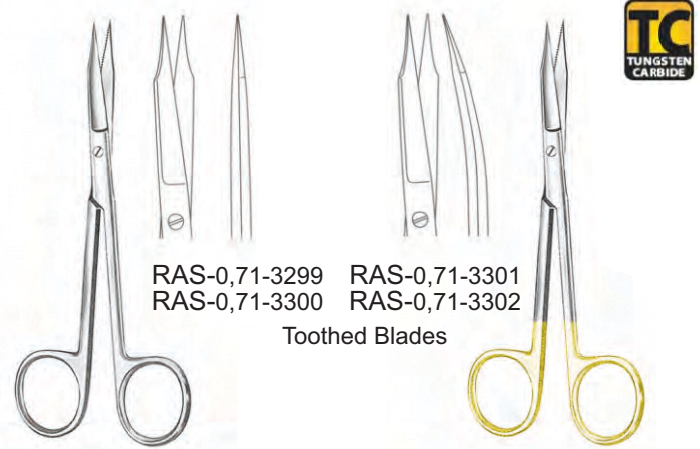

RAS-0,71-3299 RAS-0,71-3301
RAS-0,71-3300 RAS-0,71-3302

Toothed Blades

GOLDMANN-FOX
13 cm/5 1/8"

GOLDMANN-FOX
13 cm/5 1/8"

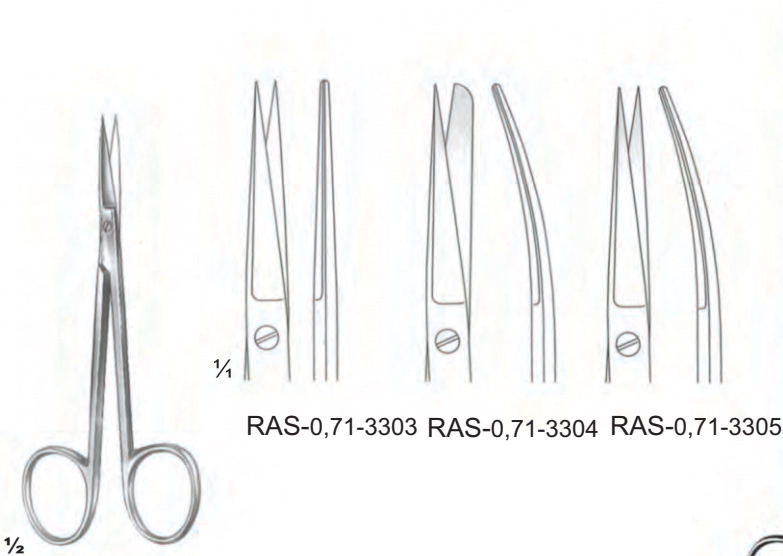

RAS-0,71-3303 RAS-0,71-3304 RAS-0,71-3305

1/2
Small modle
12 cm/4 3/4"



1/4
slender pattern
RAS-0,71-3306
RAS-0,71-3307

1/2
Toennis-Adson
17.5 cm/7"

1/2
Toennis-Adson
17.5 cm/7"

SCISSORS

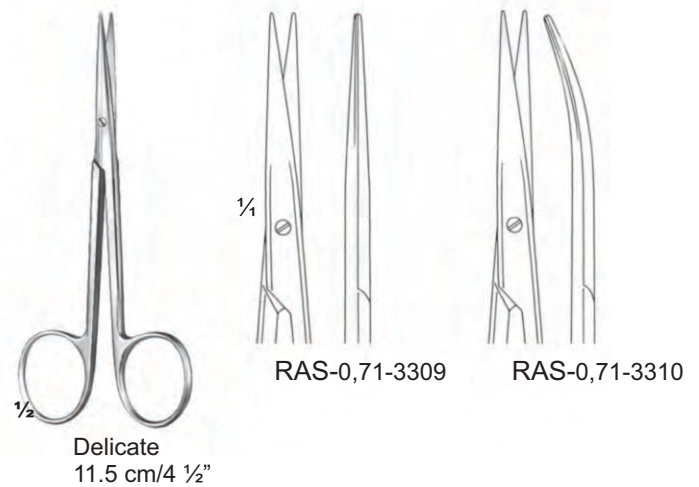
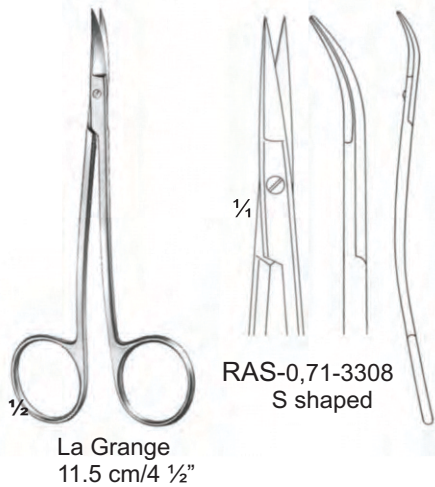

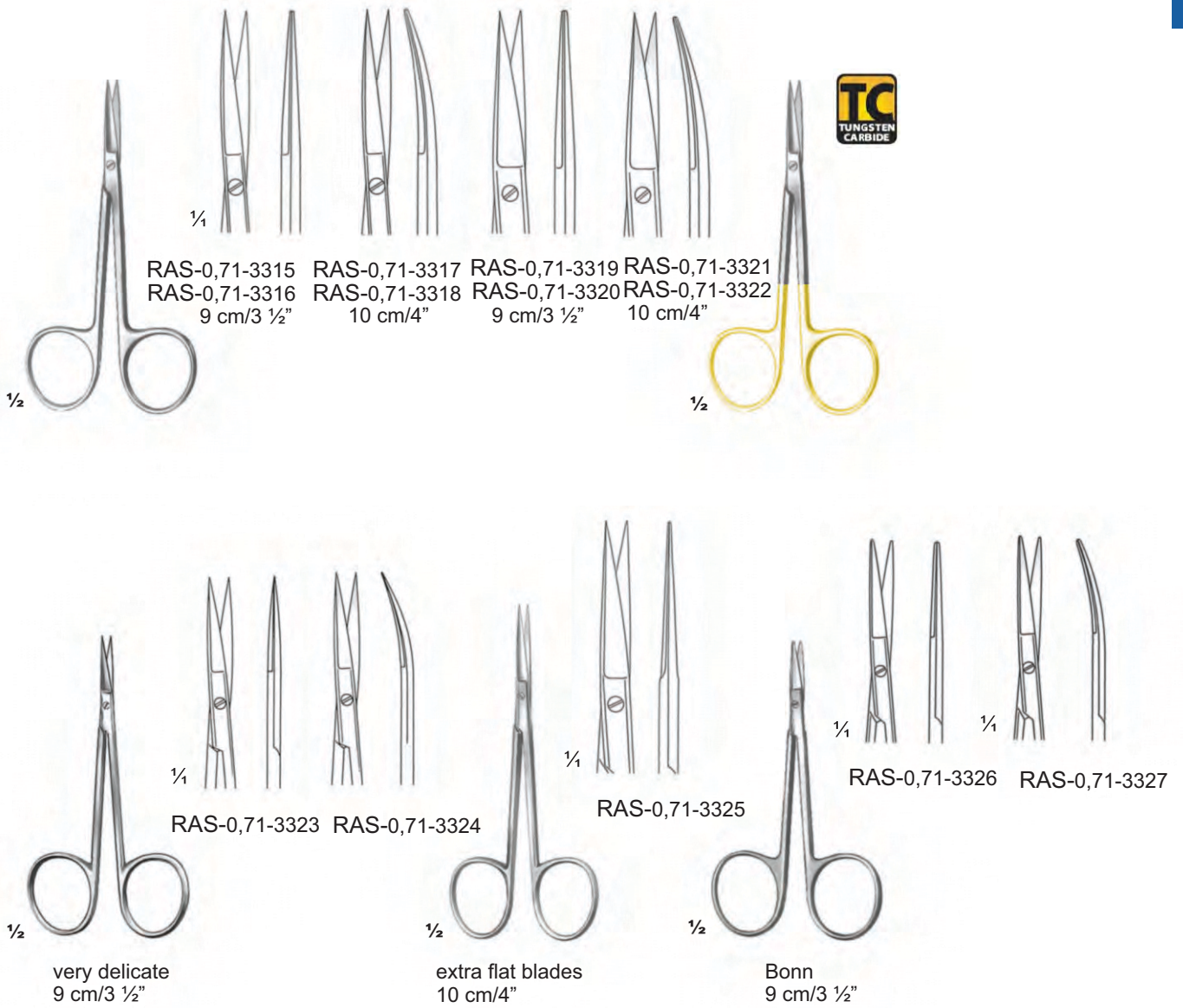

EN Iris Scissors, tendon scissors
 DE Irisscheren, Sehenscheren
 ES Tijeras para iridectomía, tijeras para tendones
 FR Ciseaux d'iris, ciseaux de tendon
 IT Iris Scissors, forbici tendine

SCISSORS



11.5 cm/4 1/2"

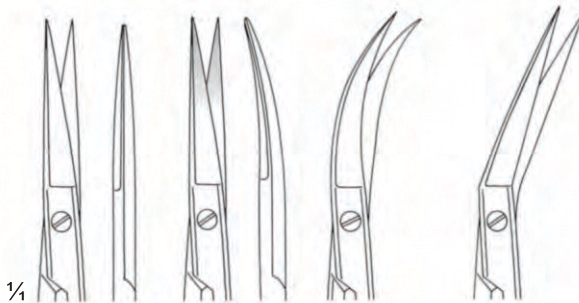

RAS-0,71-3328 RAS-0,71-3330 RAS-0,71-3332 RAS-0,71-3334
 RAS-0,71-3329 RAS-0,71-3331 RAS-0,71-3333 RAS-0,71-3335



11.5 cm/4 1/2"

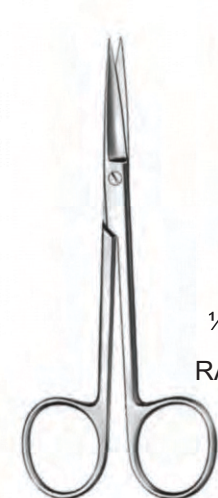

12.5 cm/5"

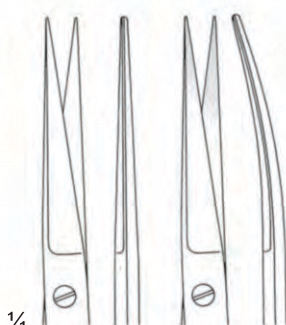

RAS-0,71-3336 RAS-0,71-3337

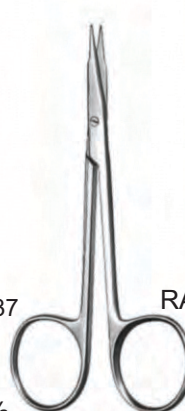

Stevens
 11 cm/4 1/2"

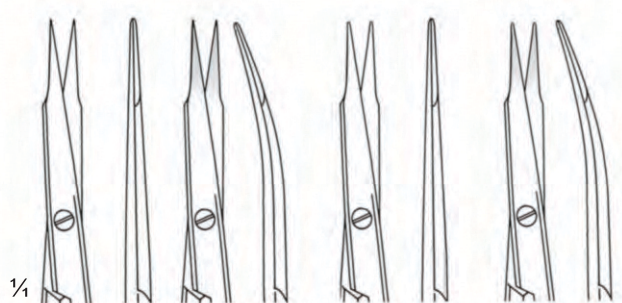

RAS-0,71-3338 sharp RAS-0,71-3339 sharp RAS-0,71-3340 blunt RAS-0,71-3341 blunt

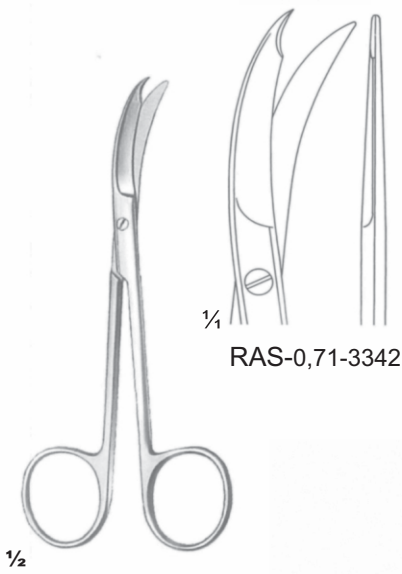

RAS-0,71-3342

1/2

Northbent
13 cm/5"

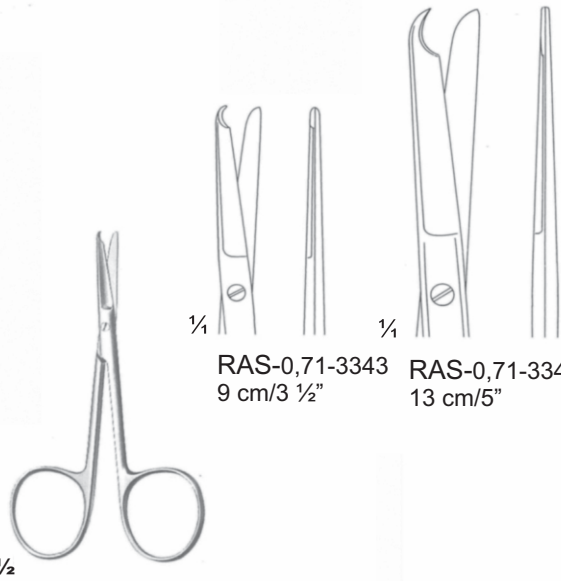

RAS-0,71-3343
9 cm/3 1/2"

1/2

Spencer



RAS-0,71-3344
13 cm/5"

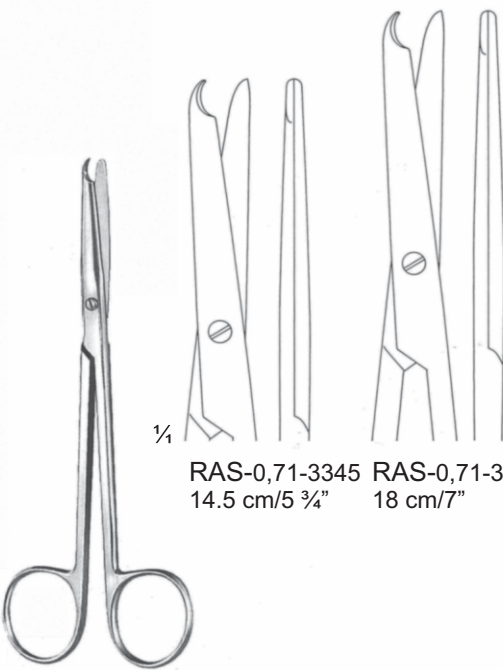

RAS-0,71-3345
14.5 cm/5 3/4"

1/2

Buck

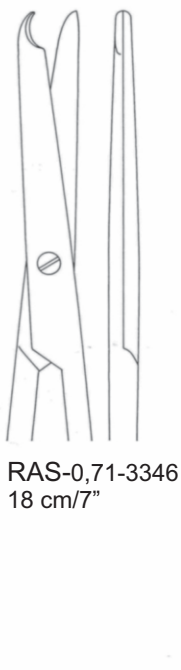

RAS-0,71-3346
18 cm/7"

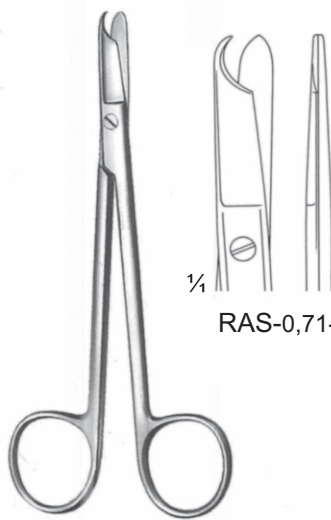

RAS-0,71-3347

1/2

Littauer
14 cm/5 1/2"

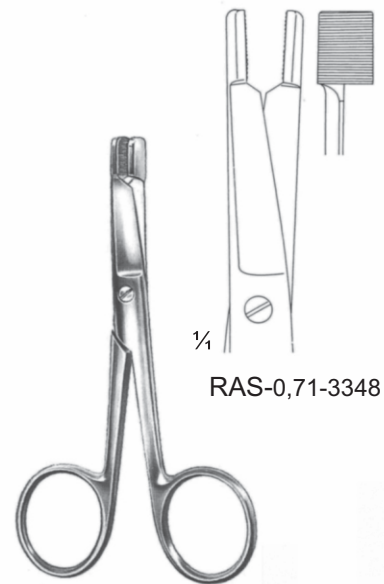

RAS-0,71-3348

1/2

Eiselsberg
12 cm/4 3/4"

EN	Bandage scissors
DE	Verbandscheren
ES	Tijeras para vendajes
FR	Ciseaux de pansement
IT	Forbici per bende

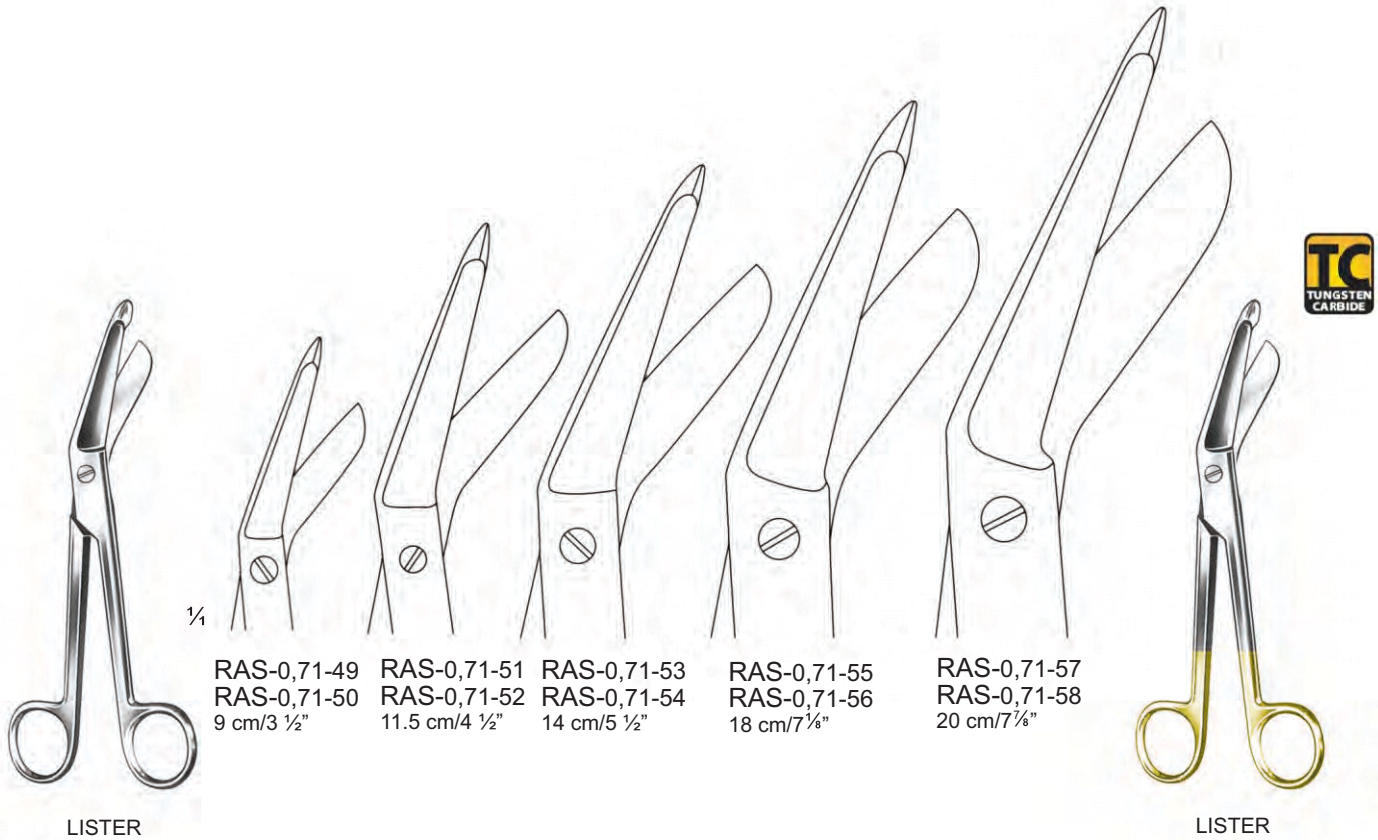

1/4	RAS-0,71-49	RAS-0,71-51	RAS-0,71-53	RAS-0,71-55	RAS-0,71-57
	RAS-0,71-50	RAS-0,71-52	RAS-0,71-54	RAS-0,71-56	RAS-0,71-58
	9 cm/3 1/2"	11.5 cm/4 1/2"	14 cm/5 1/2"	18 cm/7 1/8"	20 cm/7 7/8"

LISTER

LISTER



1/4	RAS-0,71-33	RAS-0,71-3361
	RAS-0,71-3360	RAS-0,71-3362

1/2
Wagner
12 cm/4 3/4"

1/2
Wagner
12 cm/4 3/4"

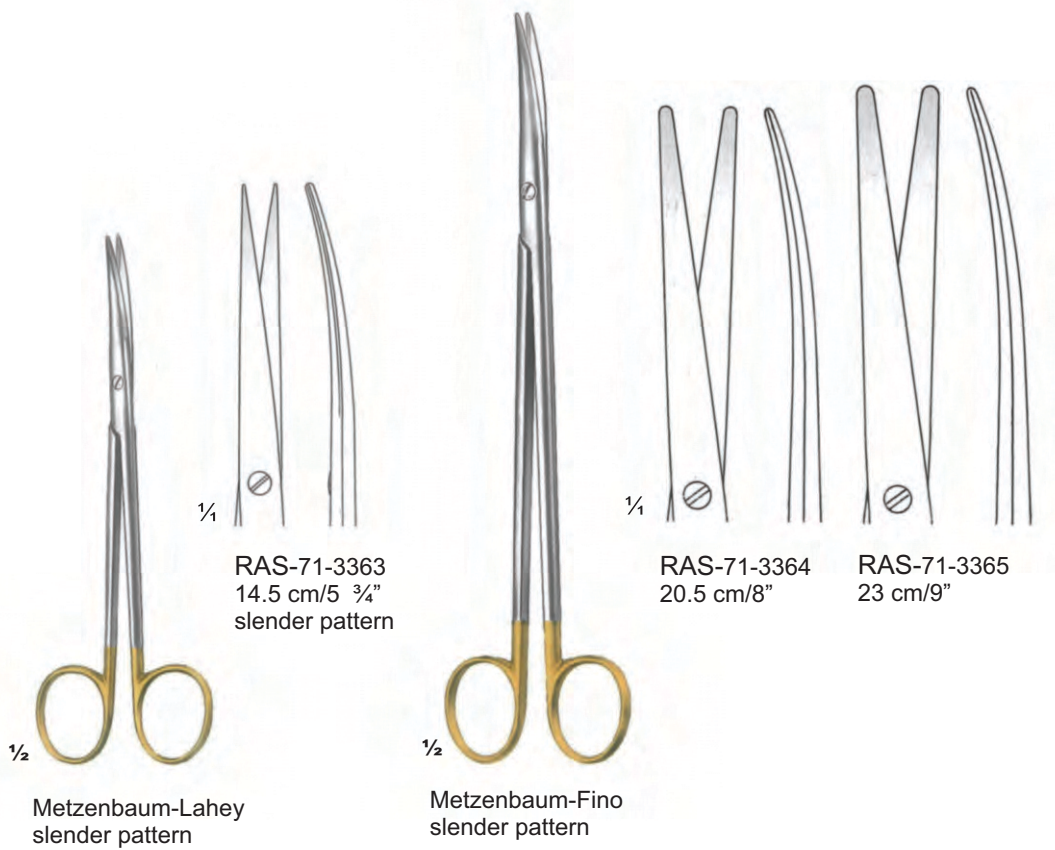

EN	Gum scissors
DE	Zahnflesischeren
ES	Tijeras para encías
FR	Ciseaux de gomme
IT	Forbici da masticare

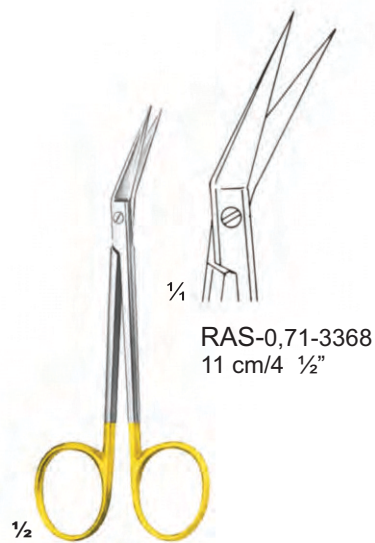
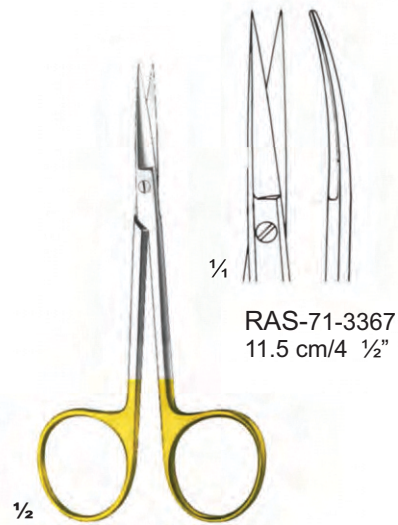
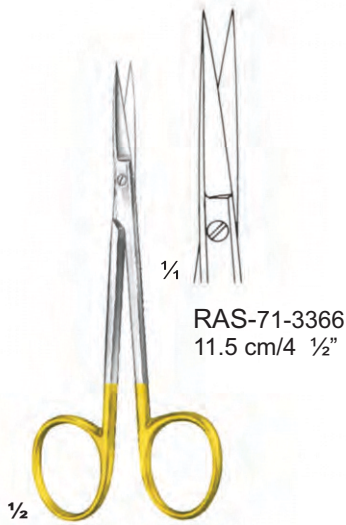

Ragnell

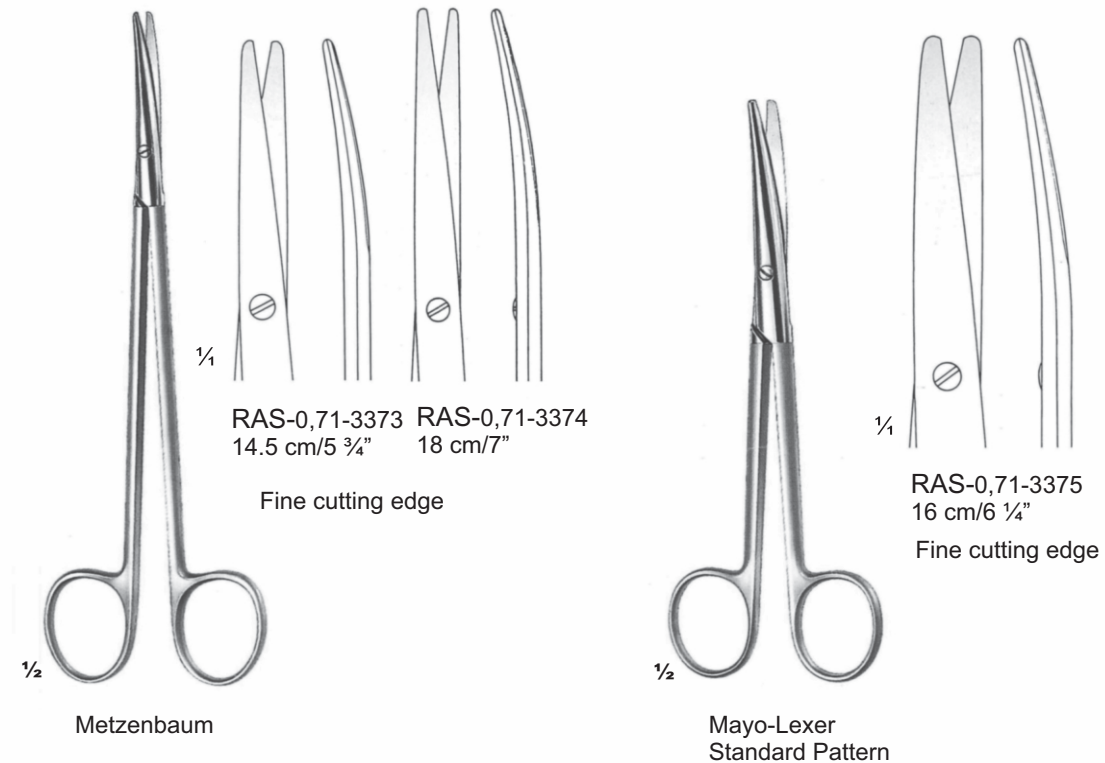
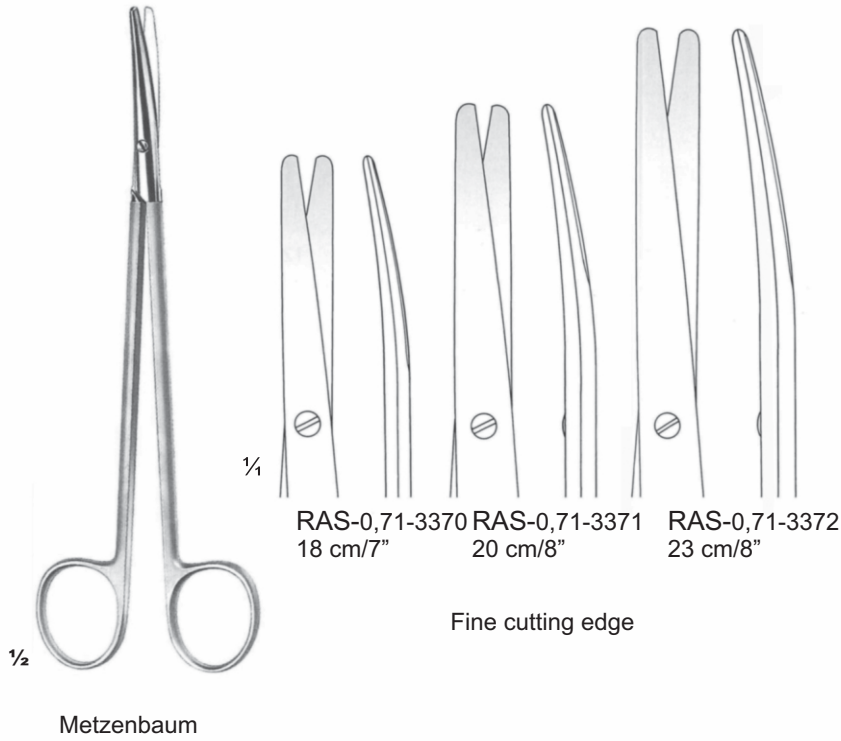

EN	Ligature scissors
DE	Ligaturscheren
ES	Tijeras para lagaduras
FR	Ciseaux à ligatures
IT	Forbici per legature

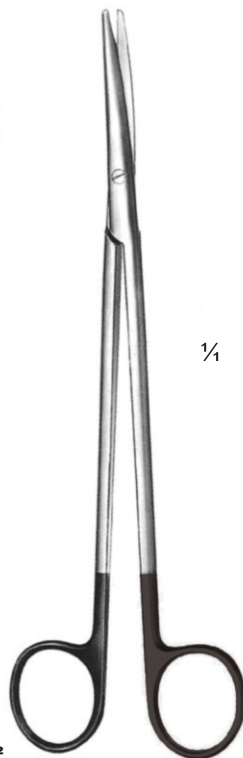

¼



RAS-0,71-3376
14.5 cm/5 ¾"



RAS-0,71-3377
18 cm/7"

For synthetic suture material
One toothed cutting edge

½



¼



RAS-0,71-3378
14.5 cm/5 ¾"



RAS-0,71-3379
17 cm/6 ¾"

For synthetic suture material
One toothed cutting edge

½

- EN** Micro Scissors
- DE** Mikroschere
- ES** Micro tijeras
- FR** Micro-ciseaux
- IT** Micro forbici

Page 172 to 173



EN	Micro Scissors
DE	Mikroscheren
ES	Micro-ciseaux
FR	Tijeras microquirúrgicas
IT	Forbici micro-chirurgici

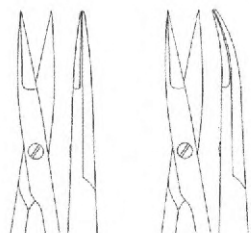

15 cm/6"	RAS-0,72-3401	RAS-0,72-3405
18 cm/7"	RAS-0,72-3402	RAS-0,72-3406
21 cm/8 1/4"	RAS-0,72-3403	RAS-0,72-3407
23 cm/9"	RAS-0,72-3404	RAS-0,72-3408

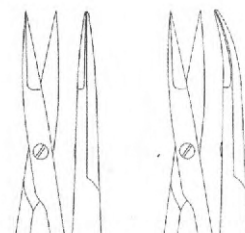

15 cm/6"	RAS-0,72-3409	RAS-0,72-3413
18 cm/7"	RAS-0,72-3410	RAS-0,72-3414
21 cm/8 1/4"	RAS-0,72-3411	RAS-0,72-3415
23 cm/9"	RAS-0,72-3412	RAS-0,72-3416



Streamlined



Streamlined



NOYES
RAS-0,72-3417
13 cm/5"

- EN** Orthodontics
- DE** Kieferorthopädie
- ES** Ortodoncia
- FR** Orthodontie
- IT** Ortodonzia

Page 174 to 190



EN	Flat nose pliers
DE	Rund-, Flachzange
ES	Pinces plates, rondes
FR	Alicates de pico plano
IT	Tenaglie piatte



RAS-0,73-3501
14 cm/5 1/2"



LANGENBECK
RAS-0,73-3502
15 cm/6"



RAS-0,73-3503
14 cm/5 1/2"



RAS-0,73-3504
12,5 cm/4 3/4"



RAS-0,73-3505
13 cm/5"



RAS-0,73-3506
14 cm/5 1/2"



GOSLEE
RAS-0,73-3507
14 cm/5 1/2"



GOSLEE
RAS-0,73-3508
14 cm/5 1/2"



GOSLEE
RAS-0,73-3509
14 cm/5 1/2"



RAS-0,73-3510
12,5 cm/4 3/4"



RAS-0,73-3511
15 cm/6"



RAS-0,73-3512
13 cm/5"

EN	Flat and round nose pliers
DE	Flach-und Rundzangen
ES	Pinces á mors plats et ronds
FR	Alicates de picos planos y redondos
IT	Tenaglie a punte piatte e rotondo



Wire cutter, front action



RAS-0,73-3519
11 cm/4 1/4"



RAS-0,73-3520
11,5 cm/4 1/2"



RAS-0,73-3521
12,5 cm/4 3/4"



RAS-0,73-3522
11,5 cm/4 1/2"



RAS-0,73-3523
11,5 cm/4 1/2"

0,7 mmØ
for hard wire up to

EN	Wire Bending Pliers
DE	Drahtbiegezangen
ES	Alicates para doblar alambre
FR	Pinces pour plier fil d'acier
IT	Pinze piega filp



1,0 mm Ø
for hard wire up to



RAS-0,73-3524
15 cm/6"



SCHWARZ
RAS-0,73-3525
13 cm/5"
Modell I



SCHWARZ
RAS-0,73-3526
13 cm/5"
Modell II



SCHWARZ
RAS-0,73-3527
13 cm/5"
Modell III



SCHWARZ
RAS-0,73-3528
14,5 cm/5 3/4"



FISCHER
RAS-0,73-3529
14 cm/5 1/2"



ANDRESEN
RAS-0,73-3530
13,5 cm/5 1/2"



McKELLOPS
RAS-0,73-3531
17 cm/6 3/4"



McKELLOPS-
STADLER
RAS-0,73-3532
16 cm/6 1/4"



STADLER
RAS-0,73-3533
15 cm/6"



ANGLE
RAS-0,73-3534
12,5 cm/5"



ANGLE
RAS-0,73-3535
12,5 cm/5"



EN Wire Bending Pliers, Loop forming pliers
 DE Drahtbiegezangen, Schlaufenbiegezangen
 ES Alicates para doblar alambre, Alicates para pliegues
 FR Pincès pour plier fil d'acier, pincès à façonner
 IT Pinzo piega filo, pinze per pieghe



ADAMS
 RAS-0,73-3536
 13 cm/5"



YOUNG
 RAS-0,73-3537
 13 cm/5"



TWEED
 RAS-0,73-3538
 13,5 cm/5 1/2"



TWEED
 RAS-0,73-3539
 13,5 cm/5 1/2"



DE LA ROSA
 RAS-0,73-3540
 12,5 cm/5"

Contouring pliers



DE LA ROSA
 RAS-0,73-3541
 12,5 cm/5"

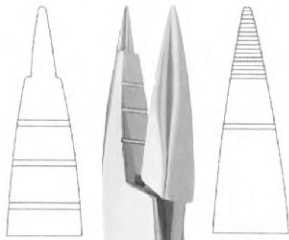

ovalen Draht bis hart 1,5 x 0,75 mm

oval wire up to 1.5 x 0.75 mm



JARABAK
RAS-0,73-3542
14 cm/5 1/2"



0,7 mm Ø
hard wire up to

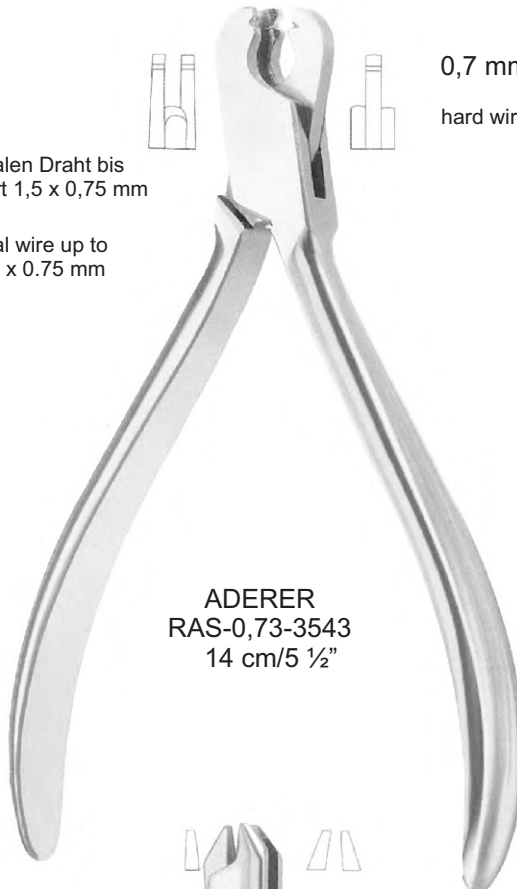

ADERER
RAS-0,73-3543
14 cm/5 1/2"



KOEHLER
RAS-0,73-3544
12 cm/4 3/4"

0,7 mm Ø
for hard wire up to



RAS-0,73-3545
14 cm/5 1/2"



0,7 mm Ø
for hard wire up to

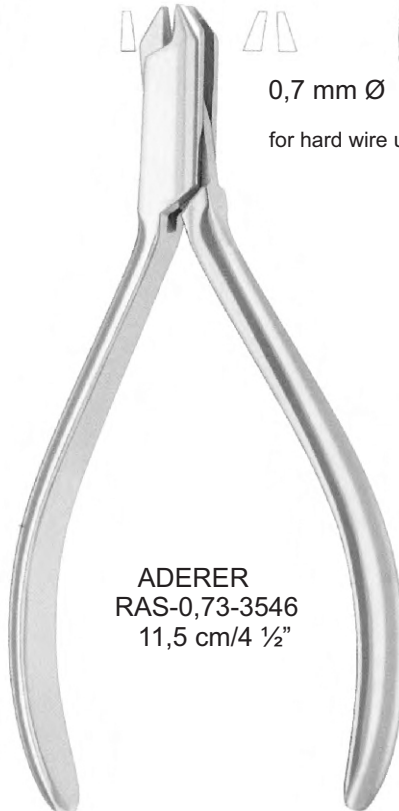

ADERER
RAS-0,73-3546
11,5 cm/4 1/2"

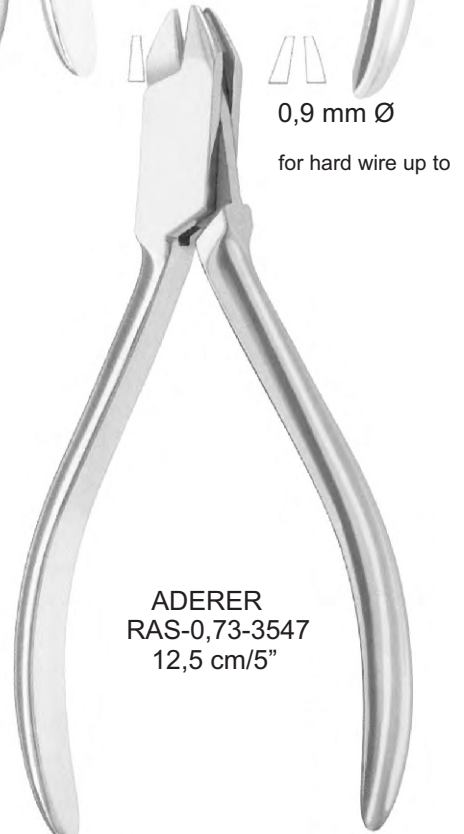

ADERER
RAS-0,73-3547
12,5 cm/5"

0,9 mm Ø
for hard wire up to

- EN Universal pliers, bridge removing pliers
 DE Universal-Kramponzange, Bruckenabnehmezangen
 ES Pincas universelles, pincas d' extraction de bridge
 FR Alicates universales, alicates para puentes
 IT Tenaglie universali, tanaglie pone di ponticeller la rimozii

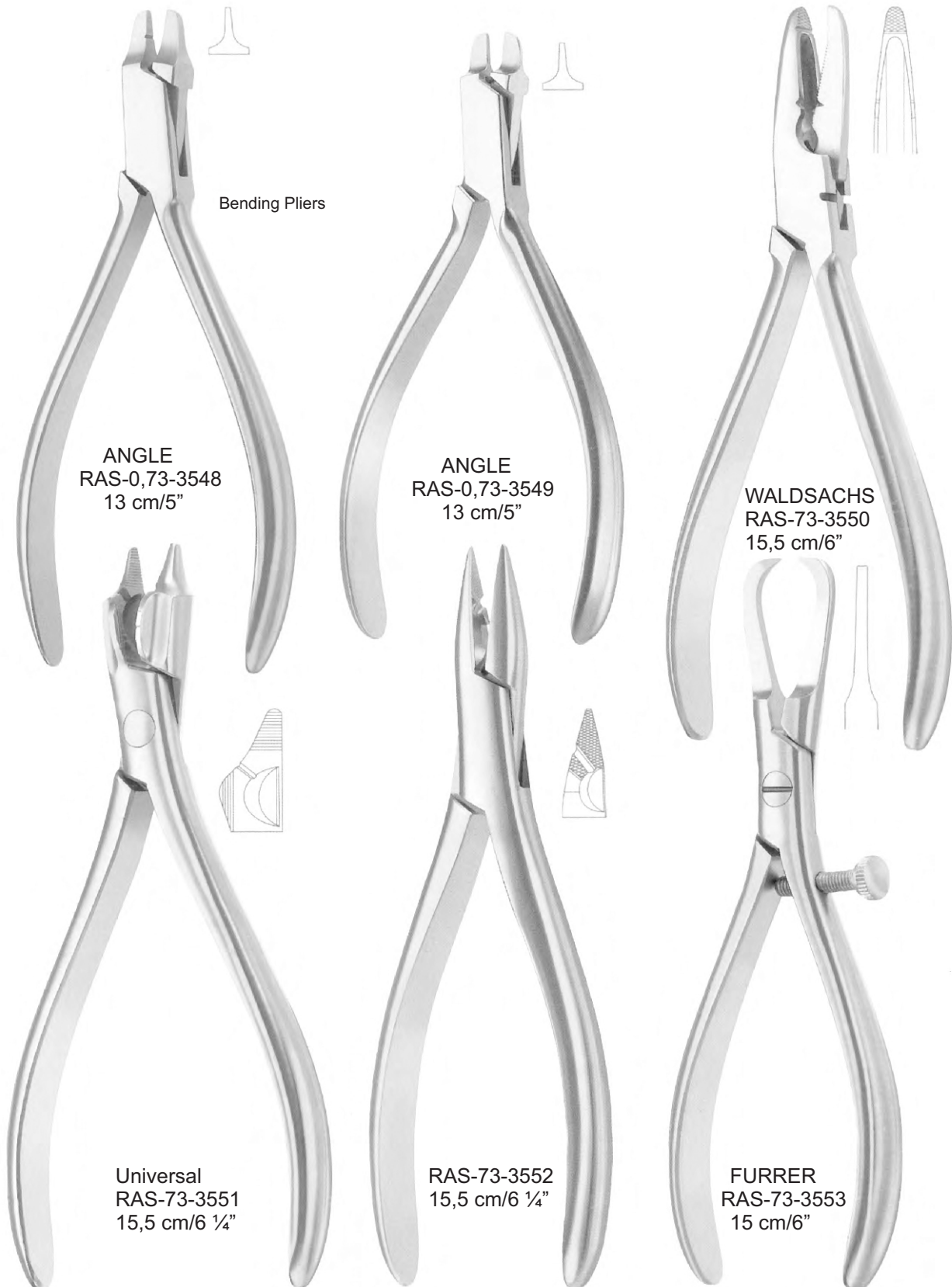

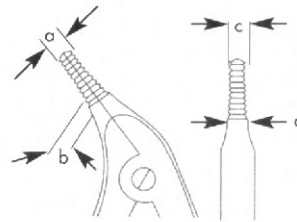

a	b	c	d
3,3	4	2,3	3,0
4,4	5	3,4	3,8

Telescope crown pliers



BOEHM
RAS-73-3554
12 cm/4 3/4"



BOEHM
RAS-73-3555
15 cm/4"

EN	Band removing pliers
DE	Bandabnehmezangen
ES	Alicatas para quitar bandas
FR	Pince à enlever les bagues
IT	Pinze asportabande



OLIVER
JONES
RAS-73-3556
15 cm/6"



OLIVER
RAS-73-3557
15 cm/6"



OLIVER
RAS-73-3558
15 cm/6"

Step loop bending pliers



ADERER
RAS-73-3559
13,5 cm/5 1/4"



NANCE
RAS-73-3560
12,5 cm/5"



0,7 mm Ø

for hard wire up to



- EN Contouring pliers, Crown pliers
- DE Konturzangen, Kronenzangen
- ES Pincas á coronne, pincas de contours
- FR Alicates para coronas y para contornear
- IT Tenaglie per corone, tenaglie per profili

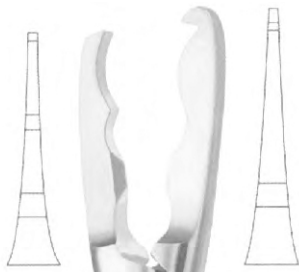

TRYFUS
RAS-73-3567
16 cm/6 1/4"

Crown
stretching pliers



smooth



PEESO
RAS-73-3568
12 cm/6 1/4"



serrated



PEESO
RAS-73-3569
13,5 cm/5 1/4"



straight



PEESO
RAS-73-3570
14 cm/5 1/2"



curved



HOW
RAS-73-3571
14 cm/5 1/2"



HOW
RAS-73-3572
14 cm/5 1/2"



RAS-73-3573
18 cm/7"



RAS-73-3574
14,5 cm/5 ¾"

EN	Contouring pliers
DE	Konturzangen
ES	Pinces a couronne
FR	Alicates para contornear
IT	Tenaglie per corone



FREVERT
RAS-73-3575
12 cm/4 3/4"



TRIPLEX
RAS-73-3576
14 cm/5 1/2"



REYNOLD
RAS-73-3577
12 cm/4 3/4"



GORDON
RAS-73-3578
13,5 cm/5 1/4"



JOHNSON
RAS-73-3579
13 cm/5"

Clamping tweezer / bracket holder



RAS-73-3580 RAS-73-3581 RAS-73-3582 RAS-73-3583 RAS-73-3584 RAS-73-3585 RAS-73-3586 RAS-73-3588 RAS-73-3587 RAS-73-3589

Bracket Band Remover Band Remover
P. Gauge

Bracket positioning gauge



RAS-73-3590

EN	Orthodontic Forceps
DE	Kieferorthopädische Pinzetten
ES	Pinzas de ortodoncia
FR	Forceps orthodontiques
IT	Forcipe ortodontico



RAS-73-3591
12.5 cm/5"



RAS-73-3592
12.5 cm/5"



RAS-73-3593
12.5 cm/5"



RAS-73-3594
12.5 cm/5"



RAS-73-3595
12.5 cm/5"



RAS-73-3596
12.5 cm/5"



RAS-73-3597
12.5 cm/5"



RAS-73-3598
12.5 cm/5"



RAS-73-3599
12.5 cm/5"



RAS-73-3600
12.5 cm/5"



RAS-73-3601
12.5 cm/5"



RAS-73-3602
12.5 cm/5"

- EN** Bone Rongeurs
- DE** Knochen Rongeur
- ES** Rongeurs de hueso
- FR** Os Rongeurs
- IT** Bone Rongeurs

Page 191 to 193



EN	Bone Rongeurs
DE	Knochenzange
ES	Roedores de hueso
FR	Bone Rongeur
IT	Roditori di ossa

BONE RONGEURS

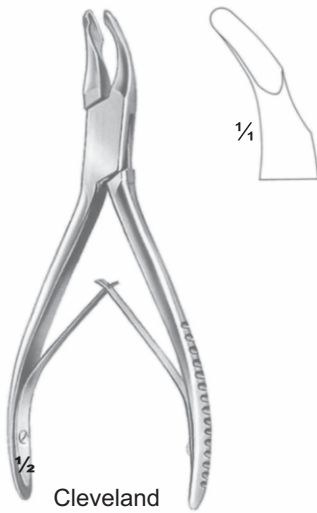

Cleveland
RAS-74-3701
15 cm



Cleveland
RAS-74-3702
15 cm

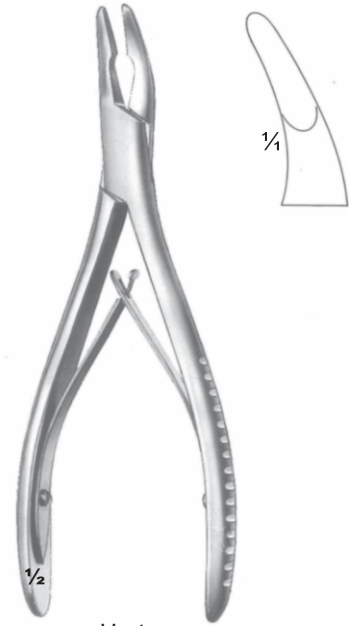

Hartmann
RAS-74-3703
18 cm



LUER
15 cm

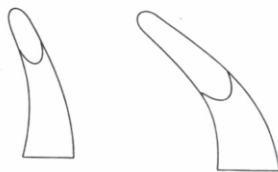

RAS-74-3704 RAS-74-3705



JM-74-3706

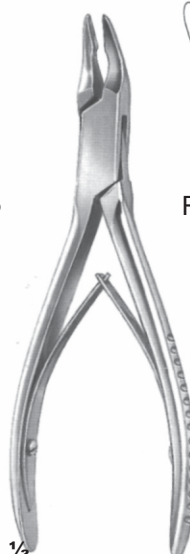

BLUMENTHAL
15 cm

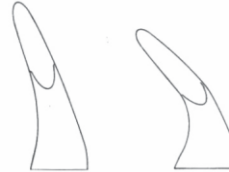

RAS-74-3707 RAS-74-3708
16 cm/6 1/4" 15.5 cm/6 1/8"



JM-74-3709
15.5 cm/6 1/8"

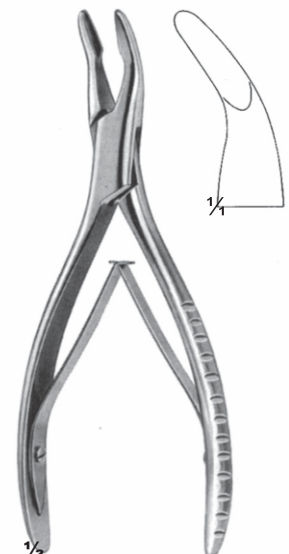

MEAD
RAS-74-3710
16.5 cm/6 1/2"



Friedmann
RAS-74-3711
14 cm



Friedmann
RAS-74-3712
14 cm



Friedmann-Micro
RAS-74-3713
15 cm/6"
straight

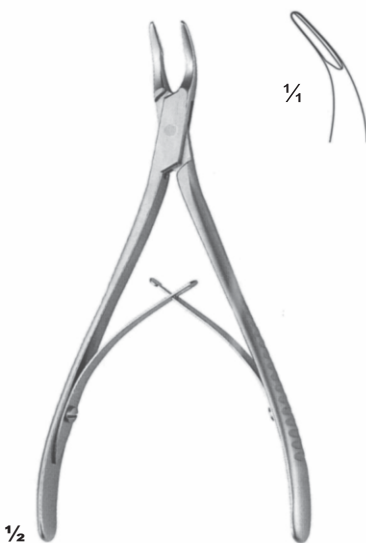

Friedmann-Micro
RAS-74-3714
15 cm/6"
30°



Friedmann-Micro
RAS-74-3715
14.5 cm/5 3/4"
90°

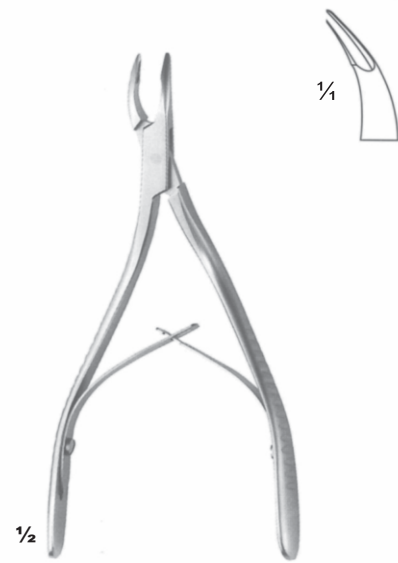

Friedmann-Micro
RAS-74-3716
14.5 cm/5 3/4"
S shape
30°

EN	Bone Rongeurs
DE	Knochennagetierte
ES	Roedores de hueso
FR	Bone Rongeur
IT	Roditori di ossa

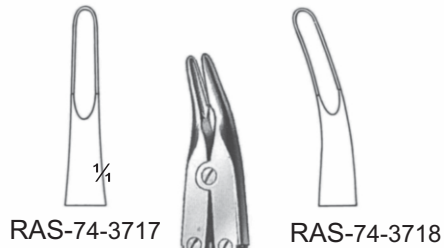

$\frac{1}{2}$
Bohler
15.5 cm/6"



$\frac{1}{2}$ Mayfield
RAS-74-3720
18 cm/7"



$\frac{1}{2}$ Zaufal-Jansen
RAS-74-3721
18 cm/7"



$\frac{1}{2}$ Ruskin
RAS-74-3722
19 cm/7 1/2"

EN	Forceps
DE	Zange
ES	Fórceps
FR	Forceps
IT	forcipe

Page 194 to 201

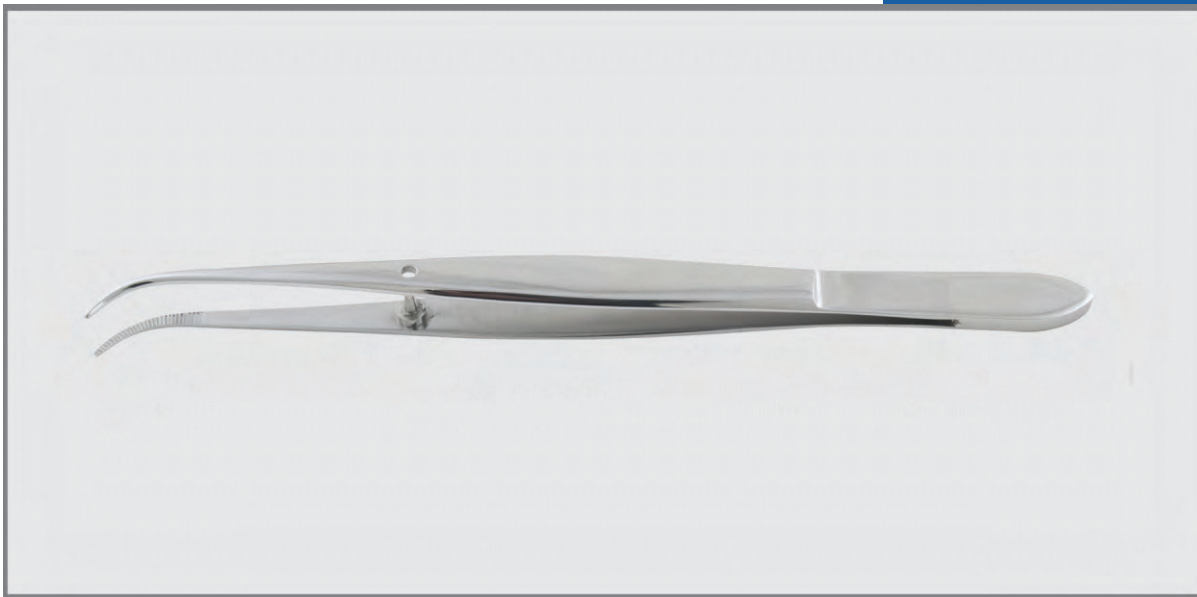

EN	Dressing Forceps
DE	Verbandzange
ES	Vendaje de fórceps
FR	Pince à pansement
IT	Pinze per medicazione

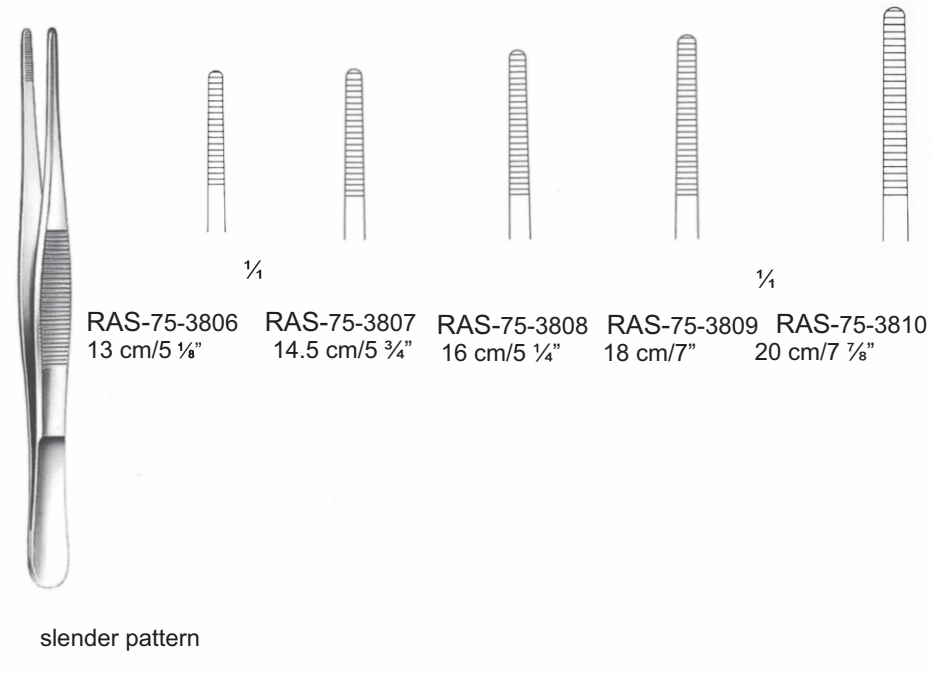
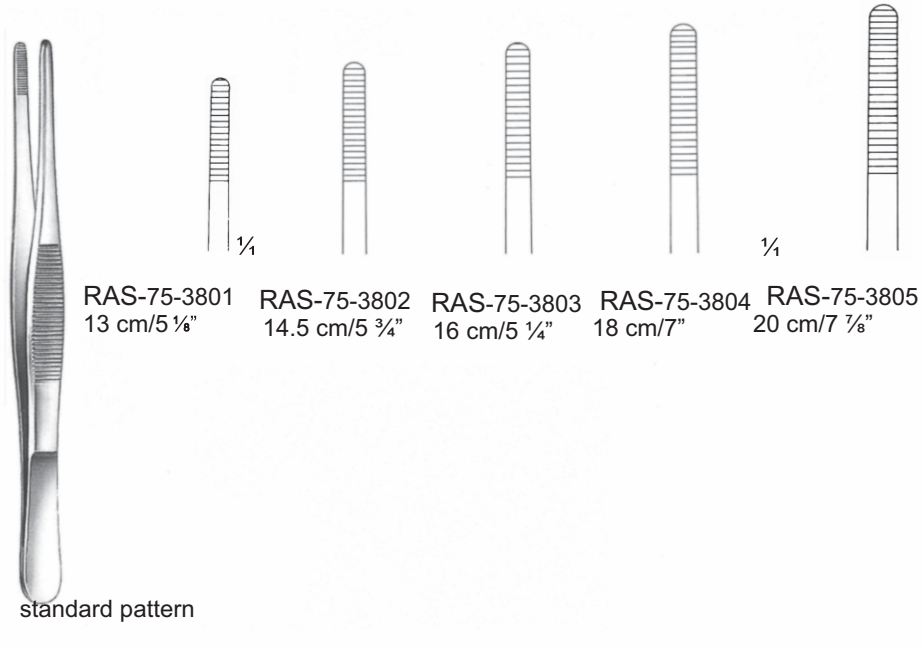

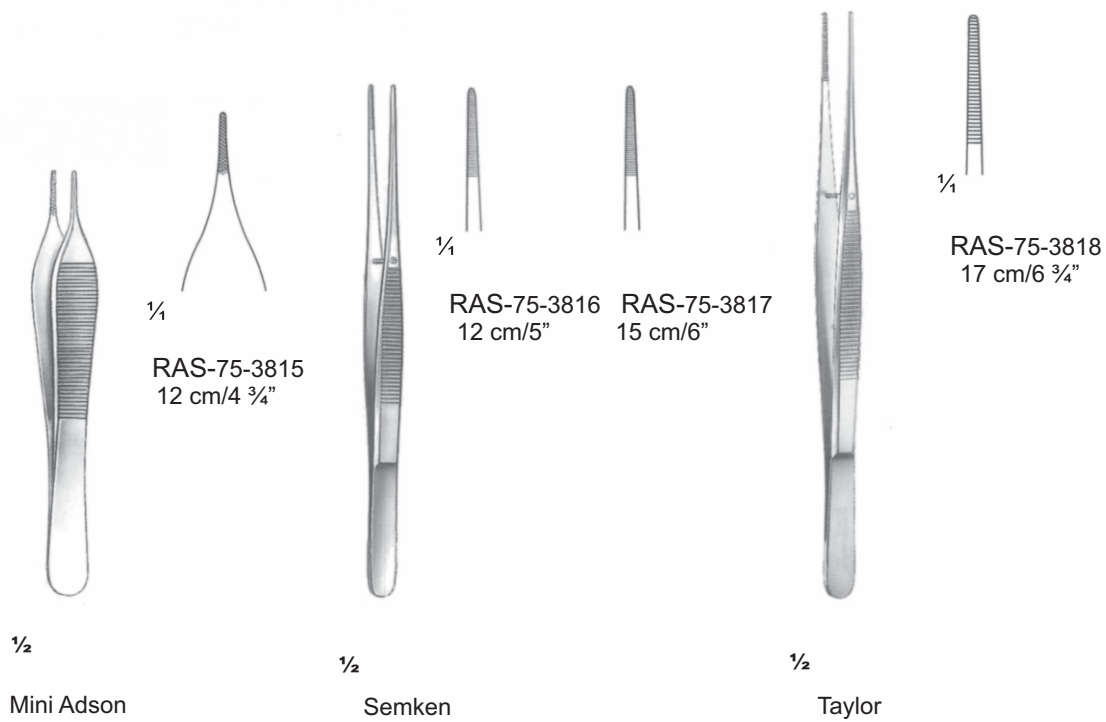
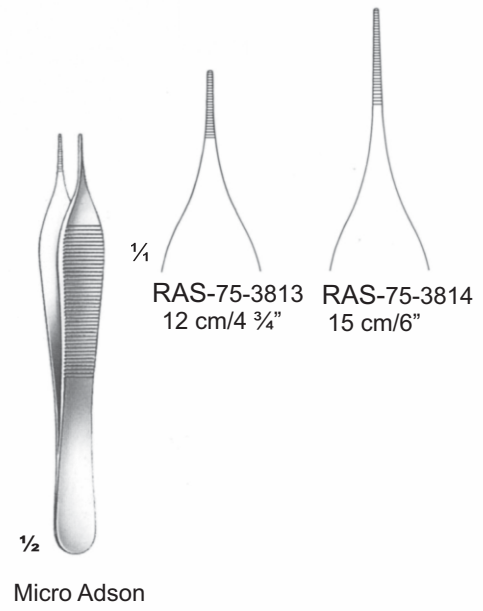
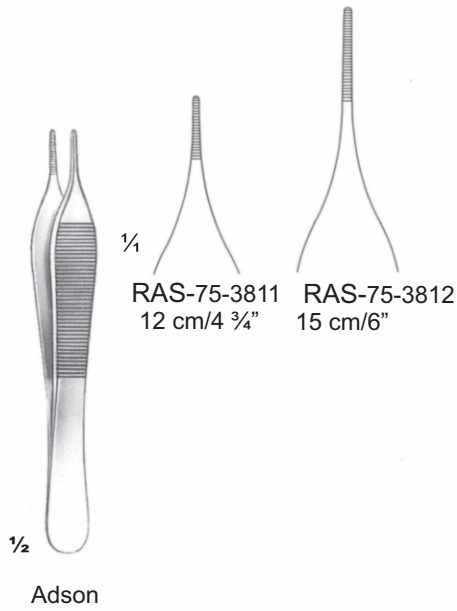

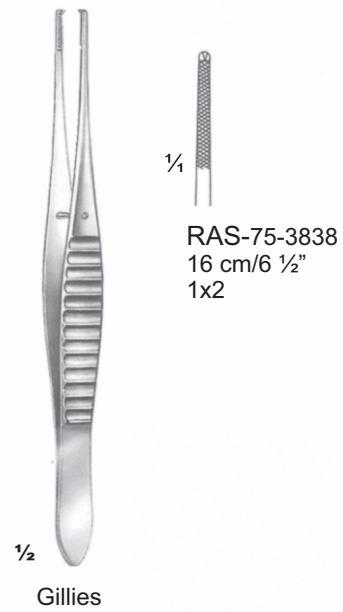
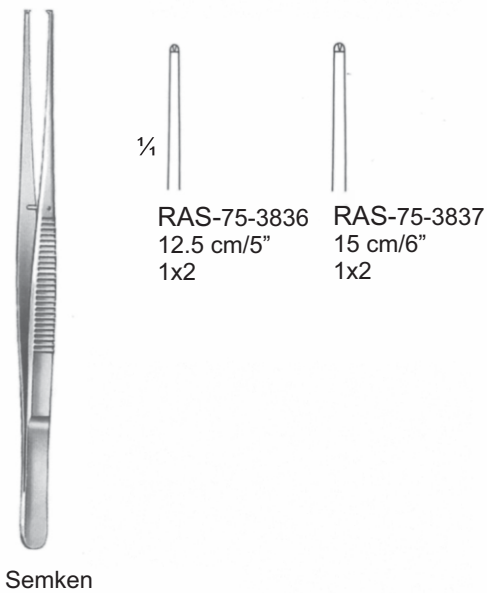
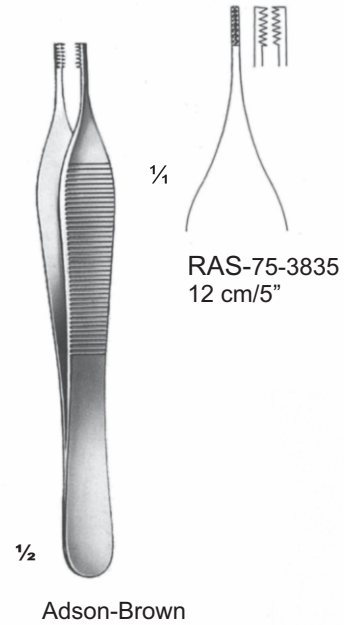
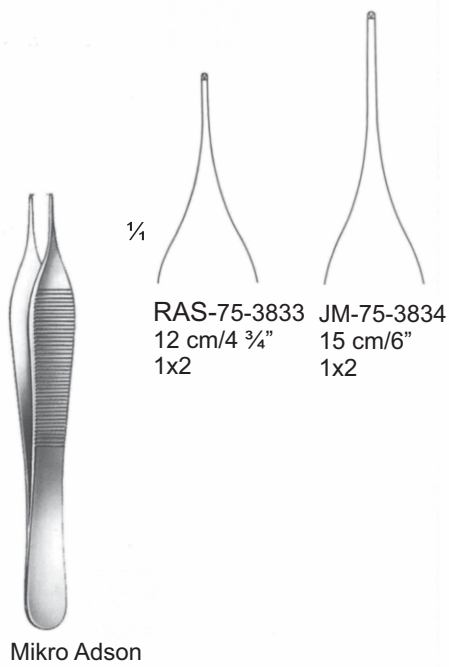

EN	Dressing Forceps
DE	Verbandzange
ES	Vendaje de fórceps
FR	Pince à pansement
IT	Pinze per medicazione

DRESSING FORCEPS

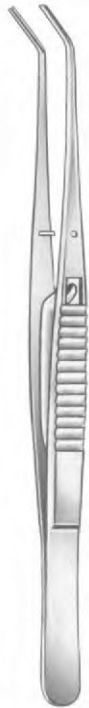

1/4
C-079-15
15 cm/6"

suited to hold silver pins, nerve-broaches and for introducing medicines



1/2
Frigz

D = 1,6 mm D = 2,2 mm



1/4
RAS-75-3839
16 cm/6 1/4"



1/4
RAS-75-3840
16 cm/6 1/4"



1/2
Frigz

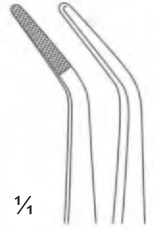

1/4
RAS-75-3841
16 cm/6 1/4"



1/2
London-College
15 cm/6"

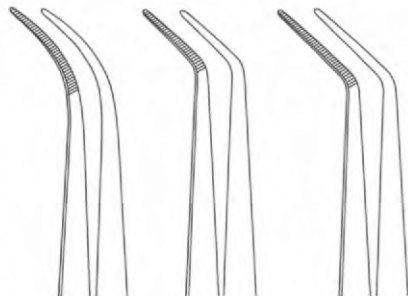

1/4
RAS-75-3842 No. 1 RAS-75-3843 No. 3 RAS-75-3844 No. 5



1/2
London-College
with lock
15 cm/6"

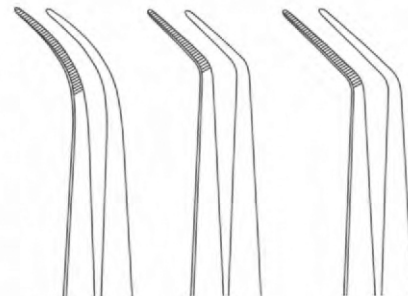

1/4
RAS-75-3845 No. 1 RAS-75-3846 No. 3 RAS-75-3847 No. 5

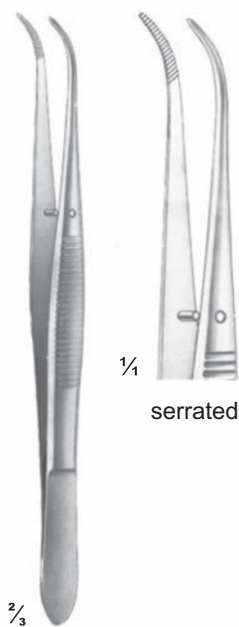

1/4
serrated

2/3
Perry
RAS-75-3848
13 cm/5"

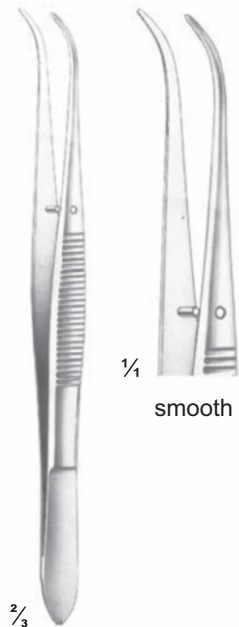

1/4
smooth

2/3
Perry
RAS-75-3849
13 cm/5"

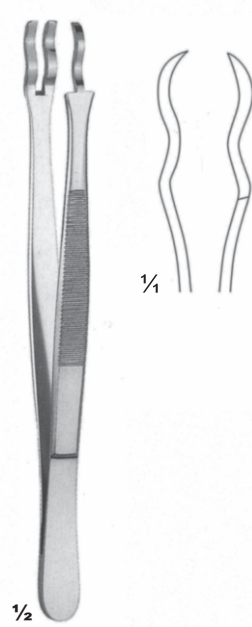

1/2
RAS-75-3850
14.5 cm/5 3/4"
Frigz
Grasping and
sterilizing forceps

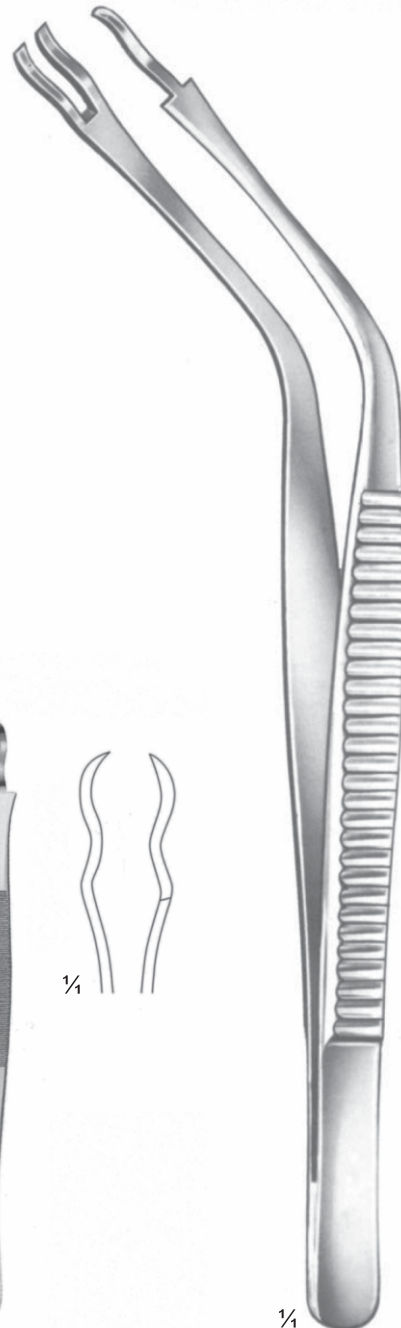

1/4
RAS-75-3851
20 cm/8"
Seizing and
Sterilizing Forceps

EN	Dressing Forceps
DE	Verbandzange
ES	Vendaje de fórceps
FR	Pince à pansement
IT	Pinze per medicazione

DRESSING FORCEPS

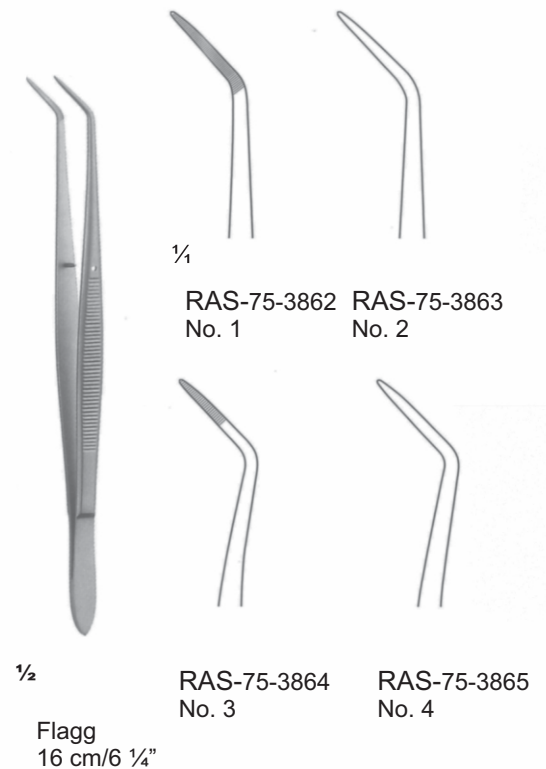
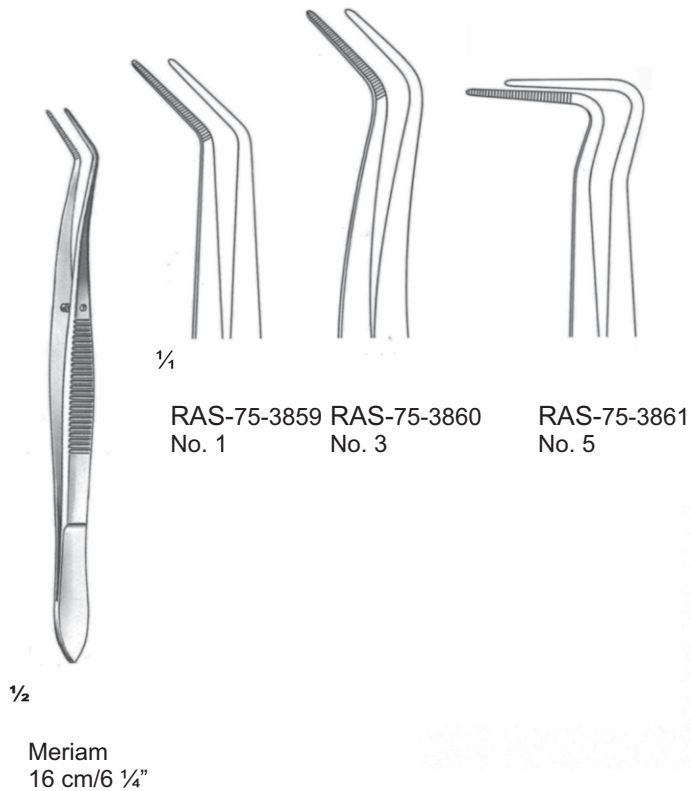
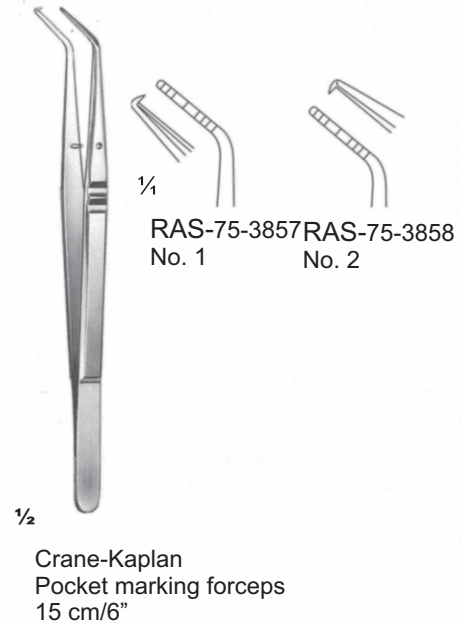
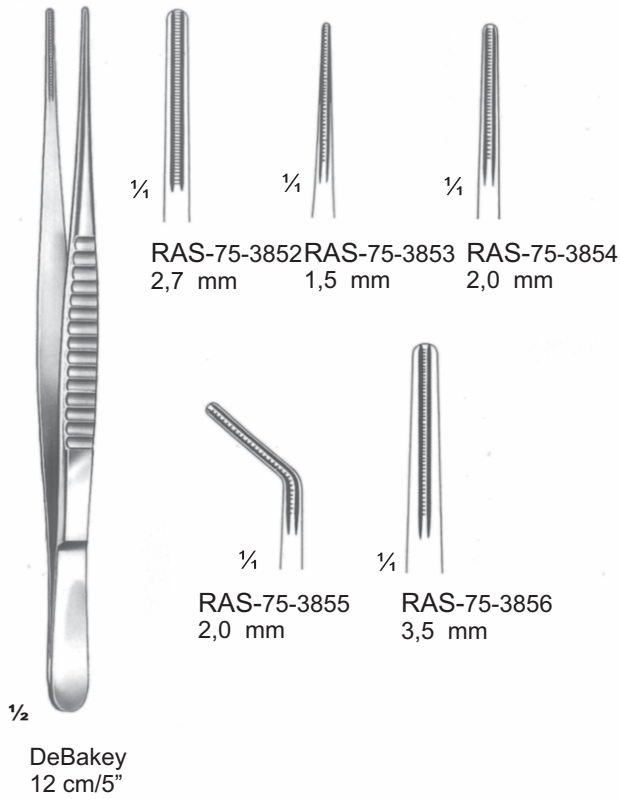

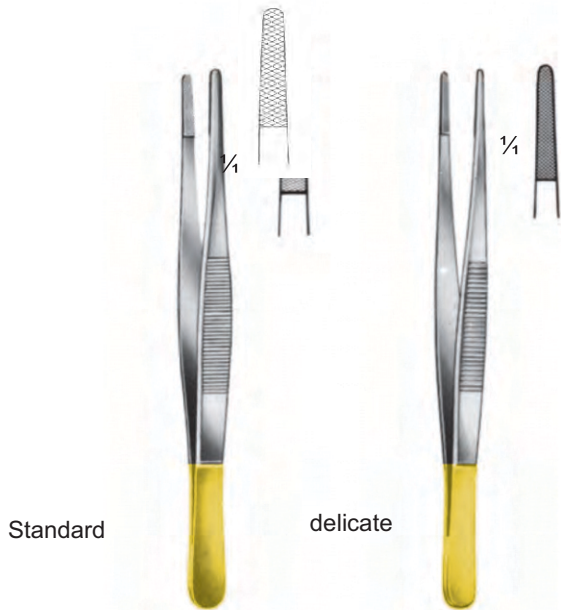

Standard

delicate

RAS-75-3866
14.5 cm/5 3/4"

RAS-75-3868
14.5 cm/5 3/4"

RAS-75-3867
18 cm/ 7"

RAS-75-3869
18 cm/7"

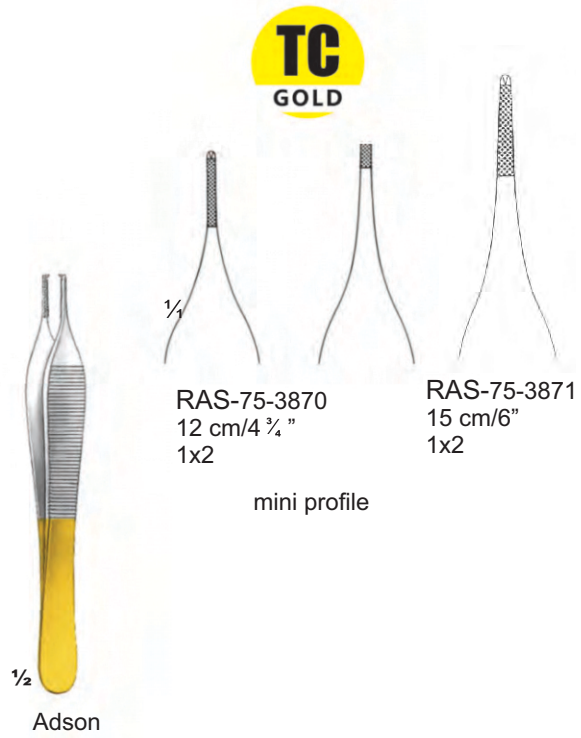

1/2
Adson

RAS-75-3870
12 cm/4 3/4"
1x2

RAS-75-3871
15 cm/6"
1x2

mini profile

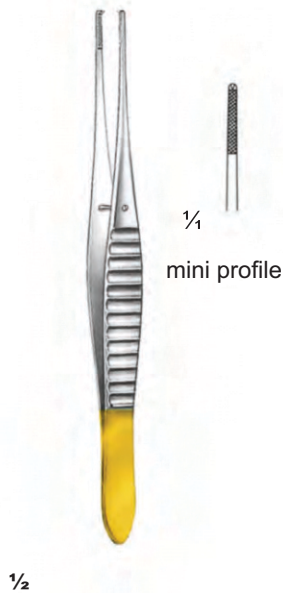

1/2

Gillies
RAS-75-3872
15.5 cm/6"
1x2

1/4
mini profile



1/2

DeBakey
RAS-75-3873
16 cm/6 1/4"

ATRAUMA

1/4
micro profile

- EN** Scalpel Handles
- DE** Skalpellgriffe
- ES** Manches de bistouris
- FR** Mangos de Bisturías
- IT** Manici per bisturi

Page 202 to 203

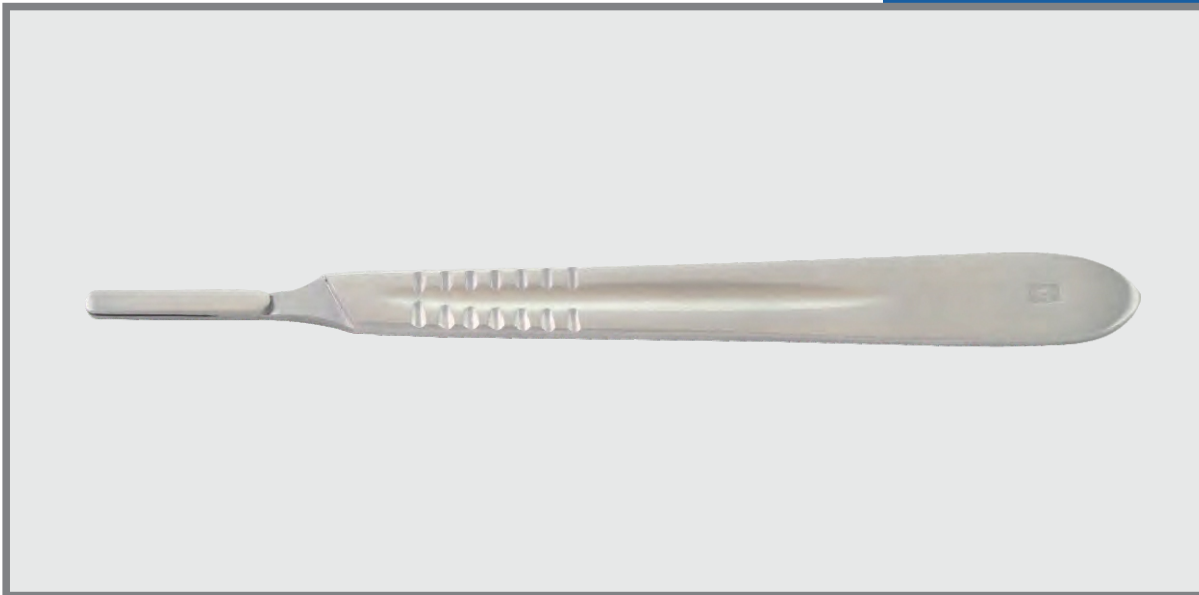

EN	Scalpel Handles
DE	Skalpelli-Griffe
ES	Mangos de bisturios
FR	Poignées de scalpel
IT	Manici per bisturi



Standard
RAS-76-3901 # 3



RAS-76-3902 # 3



RAS-76-3903 # 3
with scale



RAS-76-3904-3L # 3L
RAS-76-3905-3XL # 3XL

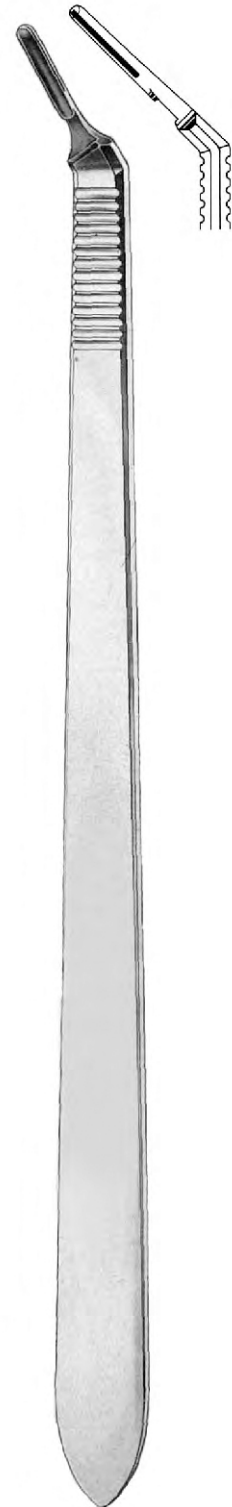

RAS-76-3906-3L # 3L
RAS-76-3907-3XL # 3XL
angled

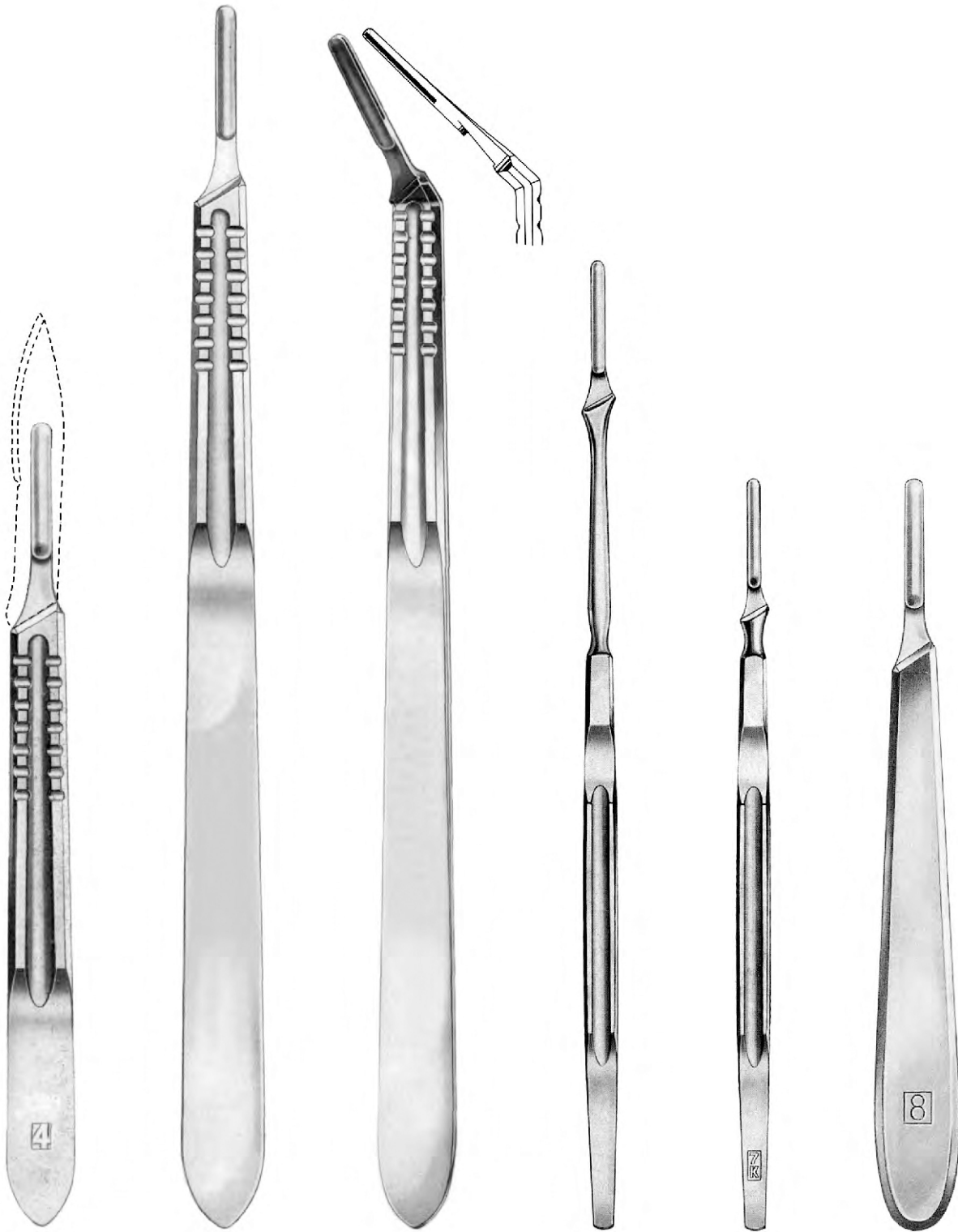

Standard
RAS-76-3908 #4

RAS-76-3909-4L #4L
RAS-76-3910-4XL #4XL

RAS-76-3911-4L #4L
RAS-76-3912-4XL #4XL
angled

RAS-76-3913 #7

RAS-76-3914 #7K

Collin
RAS-76-3915
Fig. 8

- EN** Mallets
- DE** Schlägel
- ES** Mazos
- FR** Maillets
- IT** Mallets

Page 204 to 206

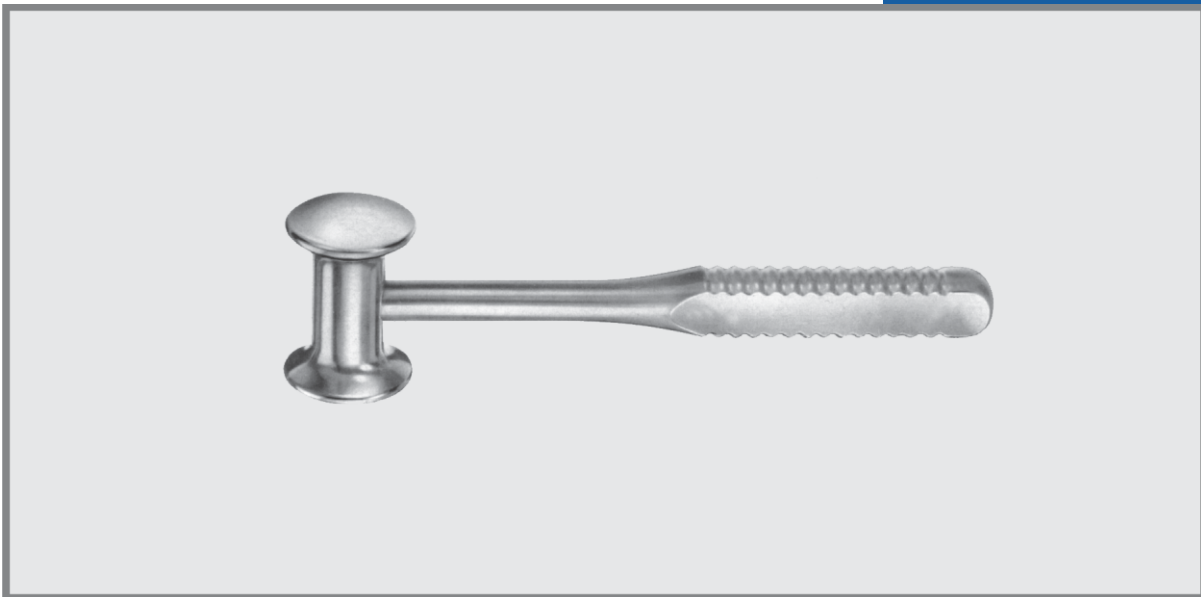

EN	Mallets
DE	Hämmer
ES	Martillos
FR	Maillets
IT	Mallets

MALLETS



BERGMANN
77-3951
24 cm/9 1/2"
300 grams



WILLIGER
24 cm/9 1/2"
lead filled



RAS-77-3952
26 mm Ø
275 g



RAS-77-3953
28 mm Ø
320 g

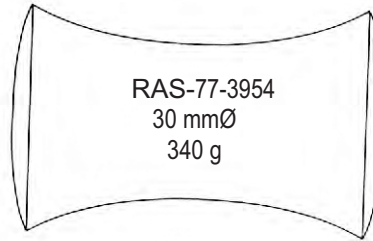

RAS-77-3954
30 mm Ø
340 g



Ø 27 mm
300 g

PARTSCH
RAS-77-3955
18 cm/7 1/8"
with hollow handle

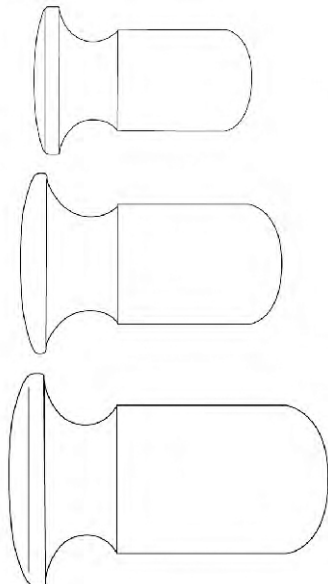

DOYEN
21 cm/8 1/4"

RAS-77-3956
25 mm Ø
120 g (4 1/4 oz.)
19.5 cm/7 3/4"

RAS-77-3957
30 mm Ø
180 g (6 1/2 oz.)
19.5 cm/7 3/4"

RAS-77-3958
35 mm Ø
260 g (9 oz.)
21 cm/8 1/4"



27 mm Ø
300 g

with interchangeable
plastic disks

MEAD
RAS-77-3959 19 cm/7 1/2"
RAS-77-3960 pair of spare disks



HAJEK
RAS-77-3961
20 cm/7⁷/₈"
200 g
Ø 27 mm



KIRK
RAS-77-3962
21 cm/8¹/₄"
650 g
Ø 38 mm



BERGMANN
RAS-77-3963
24.5 cm/9⁵/₈"
400 g
Ø 30 mm

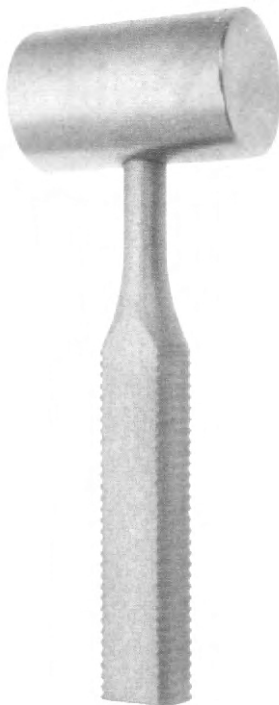

HEATH
RAS-77-3964
18.5 cm/7¹/₄"
700 g
Ø 40 mm



with interchangeable
disks
77-3966

RAS-77-3965
18.5 cm/7¹/₄"
240 g
Ø 25 mm



OMBREDANNE
RAS-77-3967
24 cm/9¹/₂"
700 g
Ø 40 mm

EN	Mallets
DE	Hämmer
ES	Martillos
FR	Maillets
IT	Mallets



RAS-77-3968
 26.5 cm/10 3/8"
 Ø 50 mm
 1300 g

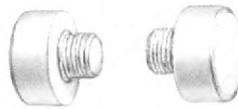

RAS-77-3969
 spare facings (pair)



RAS-77-3970
 19 cm/7 1/2"
 Ø 25 mm
 300 g



HERBERT
RAS-77-3971
 19 cm/7 1/2"
 Ø 25 mm
 215 g

- EN Cassettes
- DE Kassetten
- ES Cassettes
- FR Cassettes
- IT cassette

Page 207 to 210



EN	Instruments Cassettes
DE	Instruments Cassettes
ES	Instruments Cassettes
FR	Instruments Cassettes
IT	Cassette per strumenti



Elongated Holes

Dimension(mm)

RAS-78-400105-Instruments	78 x 182 x 32
RAS-78-400210-Instruments	142 x 182 x 32
RAS-78-400320-Instruments	270 x 182 x 32



Round Bottom with Strip Lock

Dimension(mm)

RAS-78-400405-Instruments	90 x 182 x 25
RAS-78-400510-Instruments	145 x 182 x 25
RAS-78-400620-Instruments	270 x 182 x 25

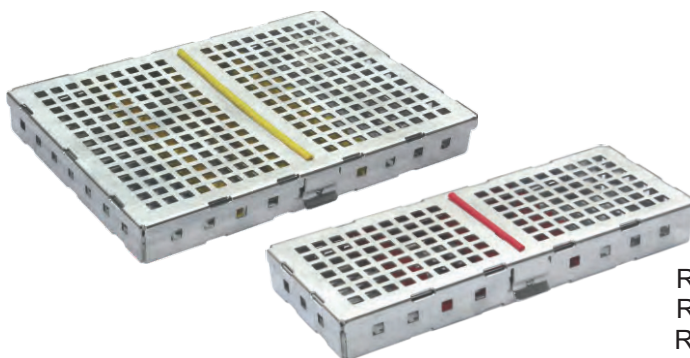

Square

Dimension(mm)

RAS-78-400705-Instruments	180 x 70 x 22
RAS-78-400810-Instruments	180 x 130 x 22
RAS-78-400920-Instruments	260 x 180 x 22

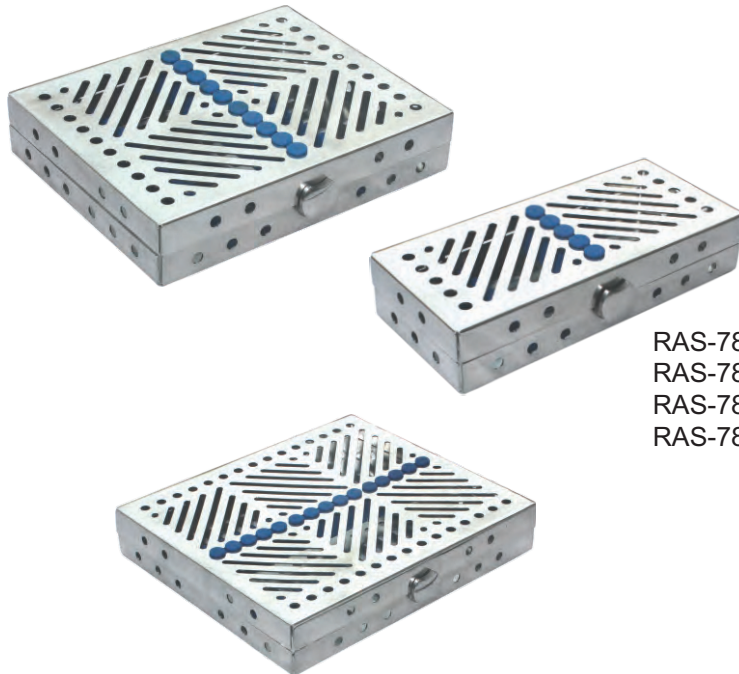

Elongated Holes

	<u>Dimension(mm)</u>
RAS-78-401005-Instruments	180 x 80 x 35
RAS-78-4011 10-Instruments	180 x 145 x 35
RAS-78-4012 15-Instruments	210 x 180 x 35
RAS-78-401320-Instruments	280 x 180 x 35

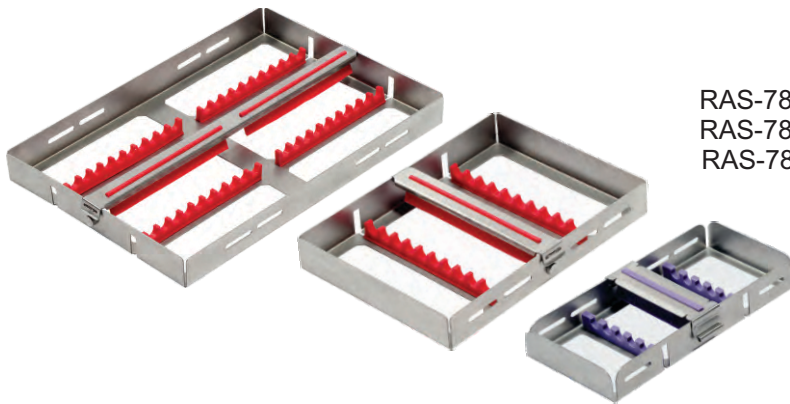

Strip Lock "H" Type

<u>Model</u>	<u>Dimension(mm)</u>
RAS-78-4014 05-Instruments	180 x 80 x 25
RAS-78-4015 10-Instruments	180 x 130 x 25
RAS-78-401620-Instruments	260 x 180 x 25

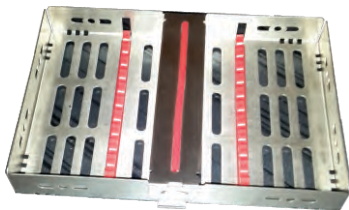

Strip Lock

<u>Model</u>	<u>Dimension(mm)</u>
RAS-78-401705-Instruments	180 x 80 x 25
RAS-78-4018 10-Instruments	180 x 130 x 25
RAS-78-401920-Instruments	260 x 180 x 25

EN	Instruments Cassettes
DE	Instruments Cassettes
ES	Instruments Cassettes
FR	Instruments Cassettes
IT	Cassette per strumenti



Dimension(mm)

RAS-78-4020405 x 255 x 50
 RAS-78-4021405 x 255 x 70
 RAS-78-4022405 x 255 x 100



Dimension(mm)

RAS-78-4023255 x 245 x 50
 RAS-78-4024255 x 245 x 70
 RAS-78-4025255 x 245 x 100



Dimension(mm)

RAS-78-4026255 x 120 x 50
 RAS-78-4027255 x 120 x 70

LIDs (optional)

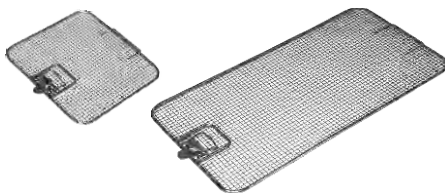

Dimension(mm)

RAS-78-4028255 x 120
 RAS-78-4029255 x 245
 RAS-78-4030250 x 240
 RAS-78-4031540 x 255
 RAS-78-4032485 x 255
 RAS-78-4033405 x 255
 RAS-78-4034480 x 370
 RAS-78-4035480 x 250

Endoscopic Baskets



Dimension(mm)

RAS-78-4036290 x 80 x 52
 RAS-78-4037460 x 80 x 52



Dimension(mm)

RAS-78-4038 670 x 80 x 52
 RAS-78-4039 700 x 80 x 52

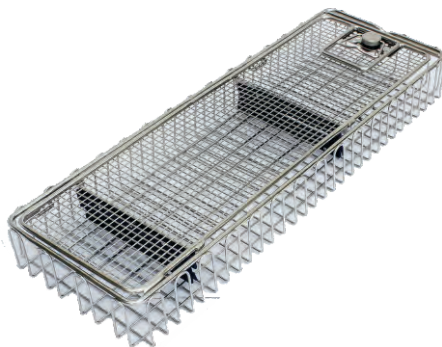

Dimension(mm)

RAS-78-4040290 x 160 x 52
 RAS-78-4041310 x 150 x 77
 RAS-78-4042460 x 160 x 77
 RAS-78-4043640 x 150 x 77
 RAS-78-4044660 x 150 x 77
 RAS-78-4045460 x 160 x 52
 RAS-78-4046580 x 160 x 52

- EN** Cylinder cartidge syringe
- DE** Zylinder-Ampullenspritze
- ES** Seringue á ampoule cylindrique
- FR** Jeringo para cartucho ampollas
- IT** Siringe ampollare a cilindro

Page 211 to 216

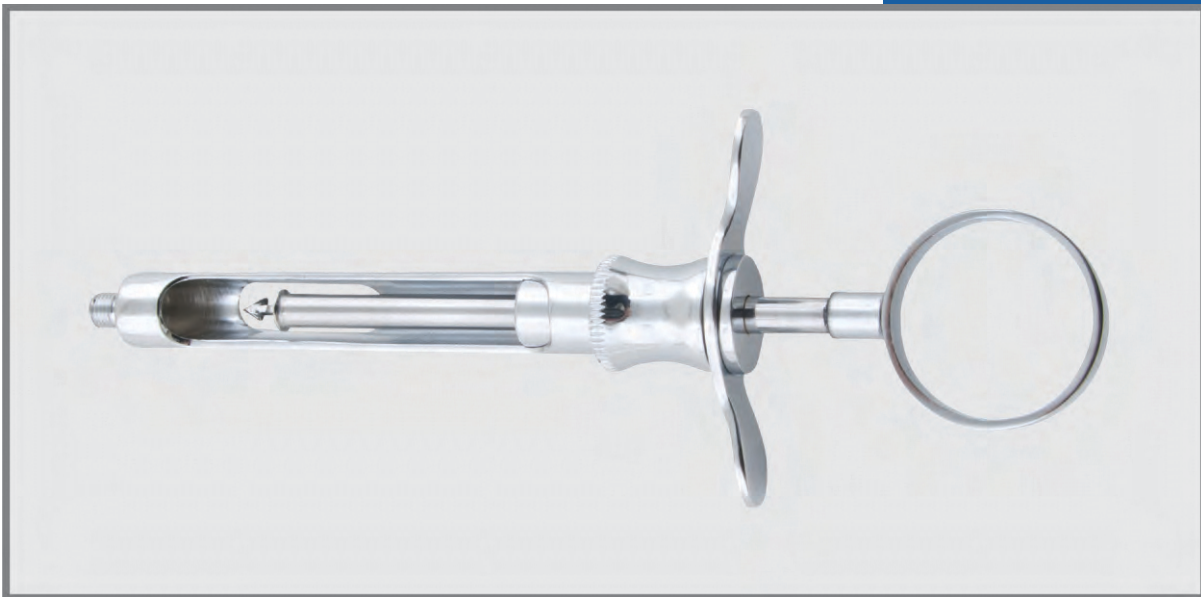

EN	Cartridge syringes
DE	Ampullenspritzen
ES	Jeringas para cartucho apollas
FR	Lima para huesos
IT	Lima per ossa



RAS-79-4101

Cylinder cartridge syringe
1.8 cc, without aspiration
metric thread / US Thread

RAS-79-4103

Cylinder cartridge syringe
2.2 cc, without aspiration
metric thread / US Thread

RAS-79-4102

Cylinder cartridge syringe
1.8 cc, with aspiration
metric thread / US Thread

RAS-79-4104

Cylinder cartridge syringe
2.2 cc, with aspiration
metric thread / US Thread



RAS-79-4105

Cylinder cartridge syringe
1.8 cc, without aspiration with
metric thread / US Thread

RAS-79-4107

Cylinder cartridge syringe
2.2 cc, without aspiration with
metric thread / US Thread

RAS-79-4106

Cylinder cartridge syringe
1.8 cc, with aspiration with
metric thread / US Thread

RAS-79-4108

Cylinder cartridge syringe
2.2 cc, with aspiration with
metric thread / US Thread



RAS-79-4109

Cylinder cartridge syringe
1.8 cc, without aspiration
metric thread / US Thread

RAS-79-4111

Cylinder cartridge syringe
2.2 cc, without aspiration
metric thread / US Thread

RAS-79-4110

Cylinder cartridge syringe
1.8 cc, with aspiration
metric thread / US Thread

RAS-79-4112

Cylinder cartridge syringe
2.2 cc, with aspiration
metric thread / US Thread



RAS-79-4113

Cylinder Cartridge Syringe
1.8cc without Aspiration
metric thread / US Thread

RAS-79-4115

Cylinder Cartridge Syringe
2.2cc without Aspiration
metric thread / US Thread

RAS-79-4114

Cylinder Cartridge Syringe
1.8cc with Aspiration
metric thread / US Thread

RAS-79-4116

Cylinder Cartridge Syringe
2.2cc with Aspiration
metric thread / US Thread

EN	Cartridge syringes
DE	Ampullenspritzen
ES	Jeringas para cartucho apollas
FR	Lima para huesos
IT	Lima per ossa



RAS-79-4117
Cylinder Cartridge Syringe
1.8cc without Aspiration
metric thread / US Thread
Plastic base & handle sand blast
finish steel rod.

RAS-79-4119
Cylinder Cartridge Syringe
2.2cc without Aspiration
metric thread / US Thread
Plastic base & handle sand blast
finish steel rod.

RAS-79-4118
Cylinder Cartridge Syringe
1.8cc with Aspiration
metric thread / US Thread
Plastic base & handle sand blast
finish steel rod.

RAS-79-4120
Cylinder Cartridge Syringe
2.2cc with Aspiration
metric thread / US Thread
Plastic base & handle sand blast
finish steel rod.



RAS-79-4121
Cylinder Cartridge Syringe
1.8cc without Aspiration
metric thread / US Thread

RAS-79-4123
Cylinder Cartridge Syringe
2.2cc without Aspiration
metric thread / US Thread

RAS-79-4122
Cylinder Cartridge Syringe
1.8cc with Aspiration
metric thread / US Thread

RAS-79-4124
Cylinder Cartridge Syringe
2.2cc with Aspiration
metric thread / US Thread



RAS-79-4125
Cylinder Cartridge Syringe
1.8cc without Aspiration
metric thread / US Thread

RAS-79-4127
Cylinder Cartridge Syringe
2.2cc without Aspiration
metric thread / US Thread

RAS-79-4126
Cylinder Cartridge Syringe
1.8cc with Aspiration
metric thread / US Thread

RAS-79-4128
Cylinder Cartridge Syringe
2.2cc with Aspiration
metric thread / US Thread



RAS-79-4129
Cylinder Cartridge Syringe
1.8cc without Aspiration
metric thread / US Thread

RAS-79-4131
Cylinder Cartridge Syringe
2.2cc without Aspiration
metric thread / US Thread

RAS-79-4130
Cylinder Cartridge Syringe
1.8cc with Aspiration
metric thread / US Thread

RAS-79-4132
Cylinder Cartridge Syringe
2.2cc with Aspiration
metric thread / US Thread

EN	Cartridge syringes
DE	Ampullenspritzen
ES	Jeringas para cartucho apollas
FR	Lima para huesos
IT	Lima per ossa



RAS-79-4133
Cylinder Cartridge Syringe
1.8cc without Aspiration
metric thread / US Thread

RAS-79-4135
Cylinder Cartridge Syringe
2.2cc without Aspiration
metric thread / US Thread

RAS-79-4134
Cylinder Cartridge Syringe
1.8cc with Aspiration
metric thread / US Thread

RAS-79-4136
Cylinder Cartridge Syringe
2.2cc with Aspiration
metric thread / US Thread



RAS-79-4137
Aspirating Syringe
1.8cc with fix tip, S/S
metric thread / US Thread

RAS-79-4138
Aspirating Syringe
2.2cc with fix tip, S/S
metric thread / US Thread

Intra-Ligamentale Syringes

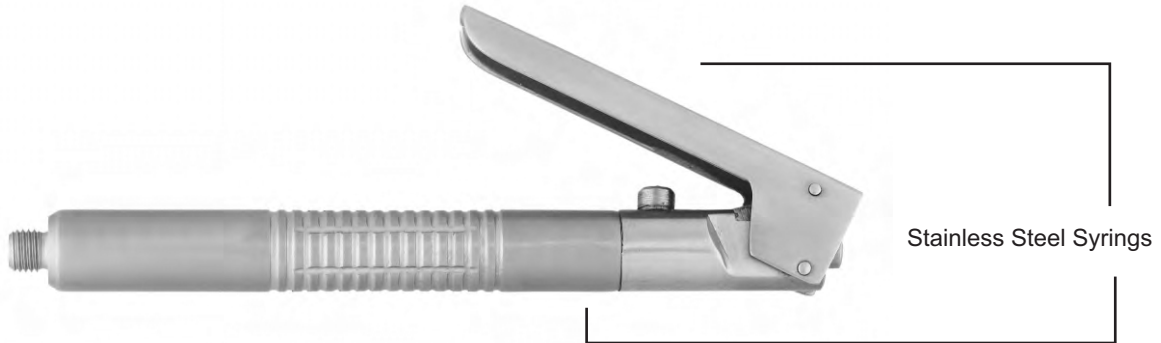

RAS-79-4139
1.8 cc metric thread / US Thread
2.2 cc metric thread / US Thread

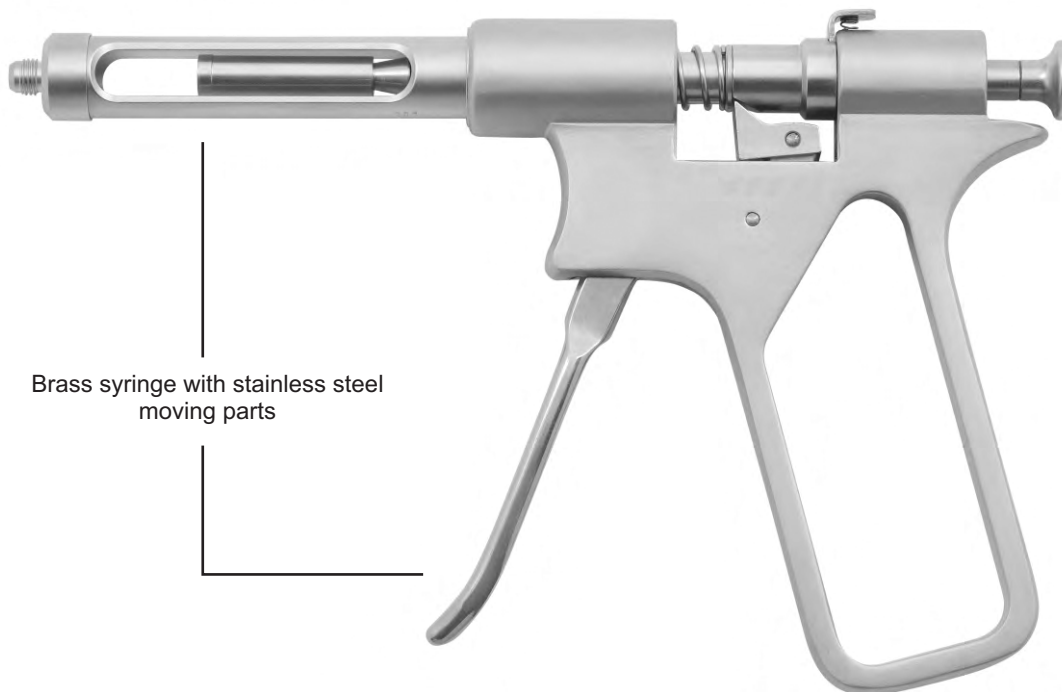

RAS-79-4140
1.8 cc metric thread / US Thread
2.2 cc metric thread / US Thread

- EN** Impression Trays
- DE** Abdrucklöffel
- ES** Porte empreintes
- FR** Cubetas para impresiones
- IT** Portaimpronte

Page 217 to 228

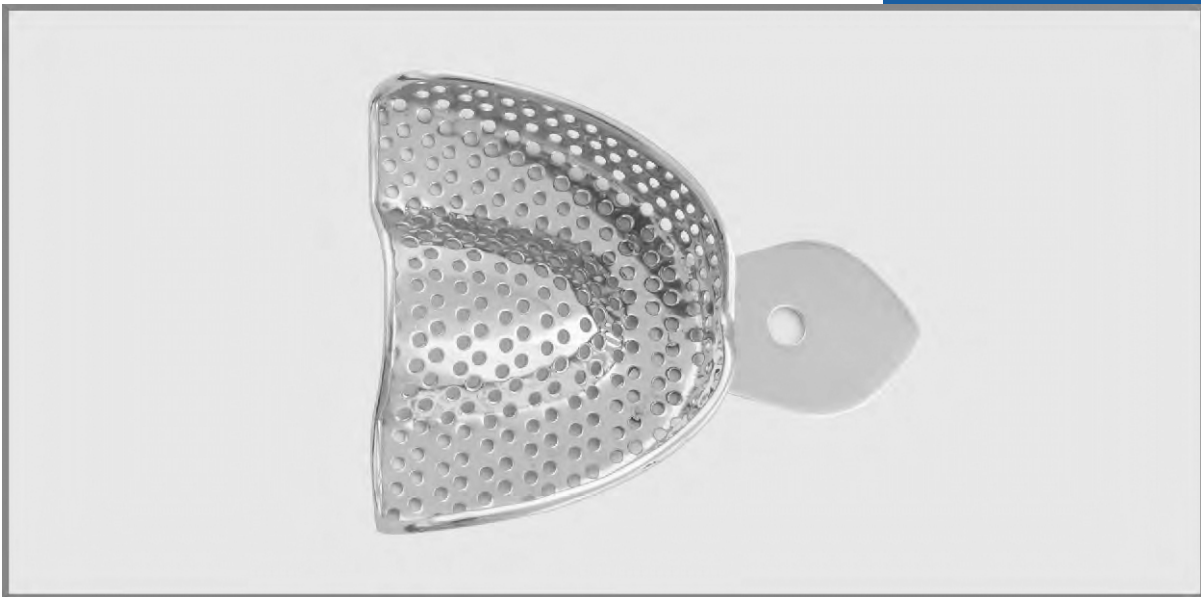

EN Impression Trays Perforated with Rim Lock
DE Abdrucklöffel perforiert mit Rim Lock
ES Bandejas de impresión perforadas con borde de bloqueo
FR Plateaux d'empreinte perforés avec verrouillage de la jante
IT Vassoio per impronta perforati con Cerchione

IMPRESSION TRAYS

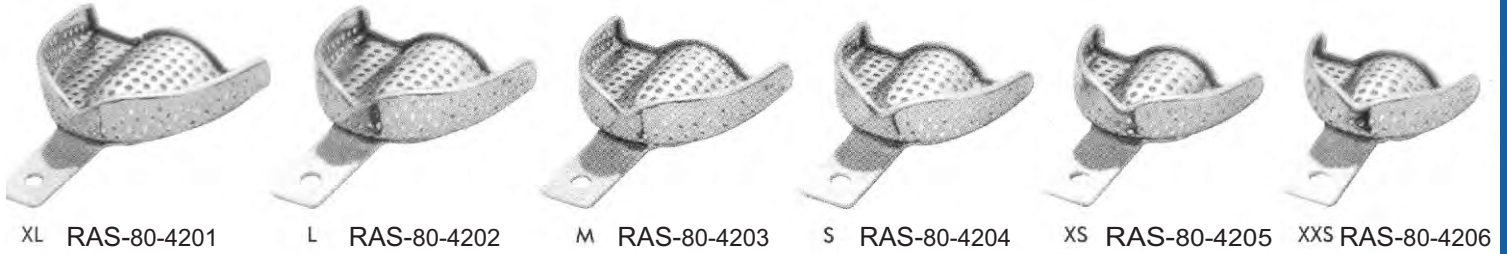

Upper		A (left-right)	B (top-bottom)
80-4201	XL	81 mm	63 mm
80-4202	L	73 mm	58 mm
80-4203	M	71 mm	52 mm
80-4204	S	67 mm	53 mm
80-4205	XS	65 mm	51 mm
80-4206	XXS	61 mm	50 mm

Lower		A (left-right)	B (top-bottom)
80-4207	XL	78 mm	63 mm
80-4208	L	74 mm	62 mm
80-4209	M	72 mm	59 mm
80-4210	S	70 mm	57 mm
80-4211	XS	69 mm	55 mm
80-4212	XXS	59 mm	50 mm

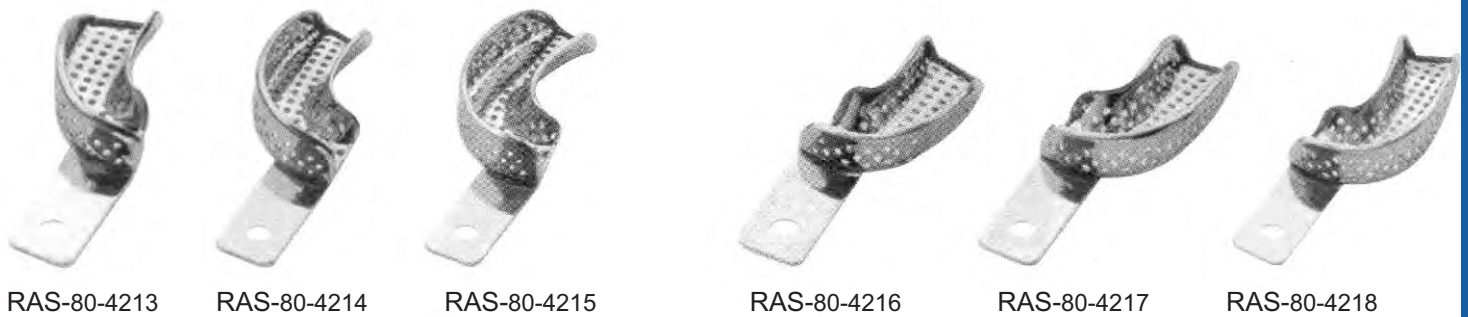
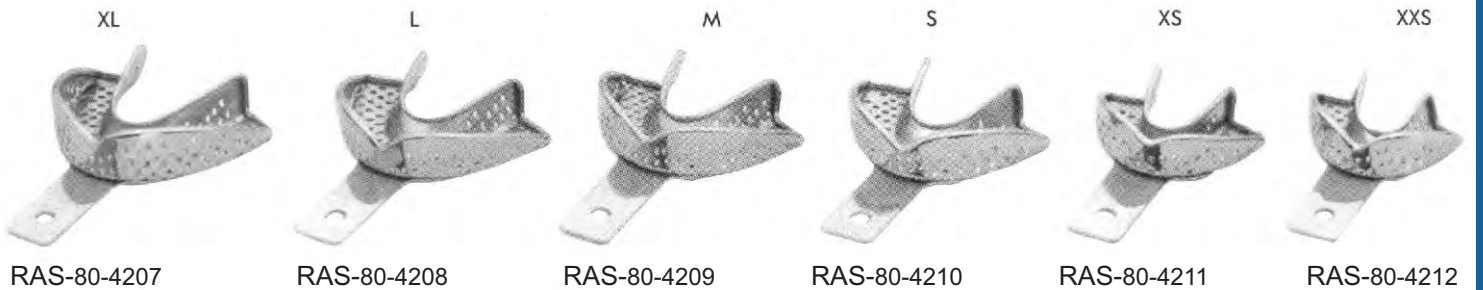

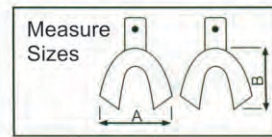
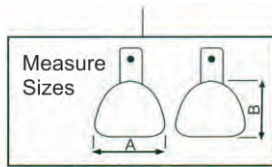
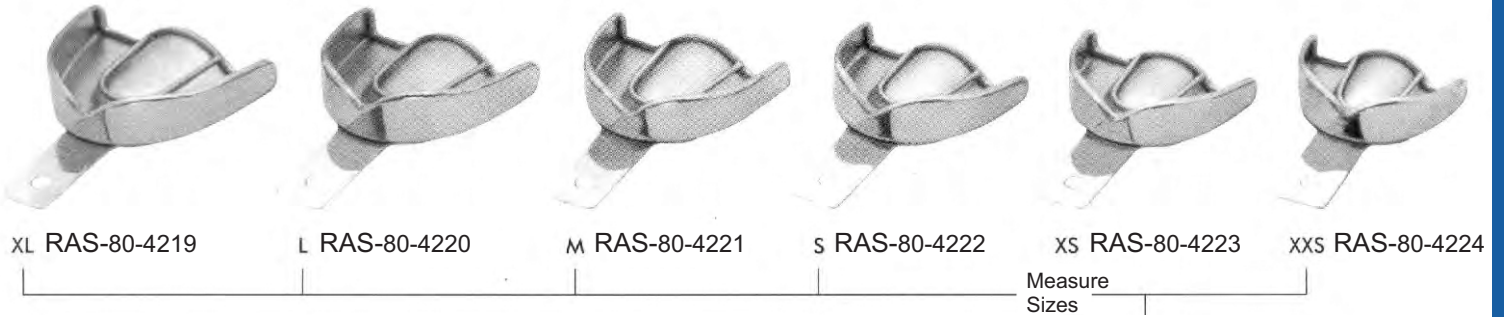

Upper		A (left-right)	B (top-bottom)
81-4219	XL	81 mm	63 mm
81-4220	L	73 mm	58 mm
81-4221	M	71 mm	52 mm
81-4222	S	67 mm	53 mm
81-4223	XS	65 mm	51 mm
81-4224	XXS	61 mm	50 mm

Lower		A (left-right)	B (top-bottom)
81-4225	XL	78 mm	63 mm
81-4226	L	74 mm	62 mm
81-4227	M	72 mm	59 mm
81-4228	S	70 mm	57 mm
81-4229	XS	69 mm	55 mm
81-4201	XXS	59 mm	50 mm

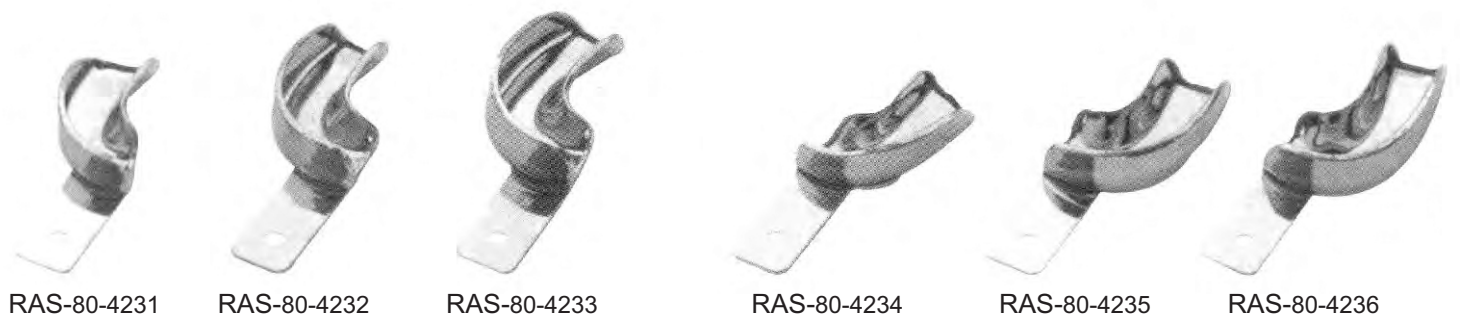
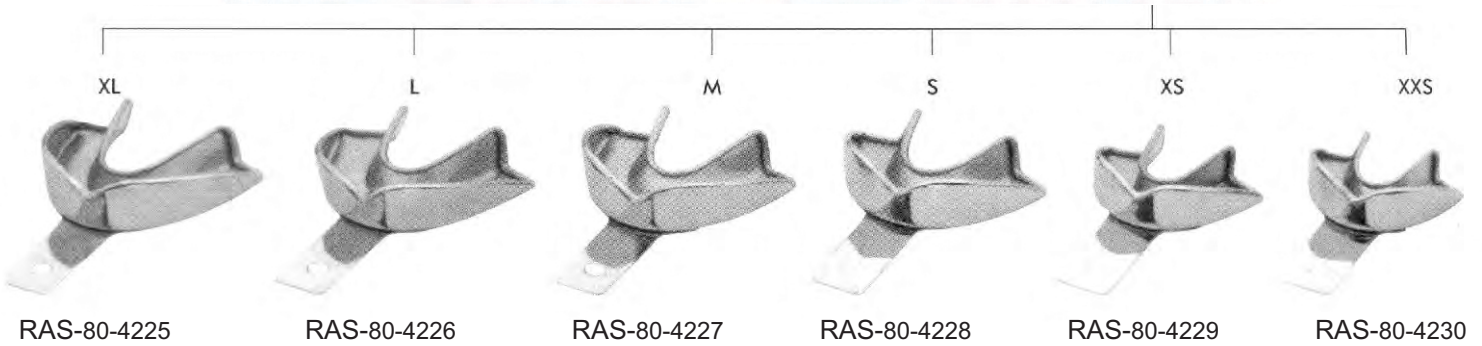

- EN** Impression Trays Solid with Rim Lock
- DE** Abformlöffel Solid mit Rim Lock
- ES** Bandejas de impresión sólidas con borde de bloqueo
- FR** Bacs à empreintes Solid avec Rim Lock
- IT** Vassoi per impronte solidi con blocco del bordo

IMPRESSION TRAYS

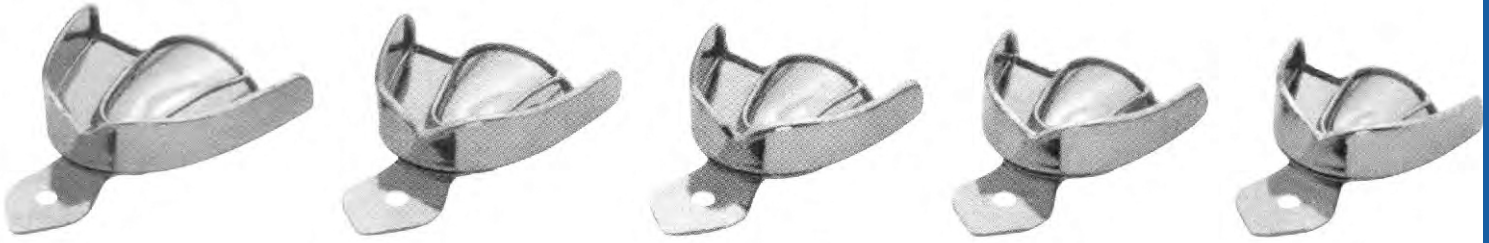

RAS-80-4237 RAS-80-4238 RAS-80-4239 RAS-80-4240 RAS-80-4241
 XL L M S XS

Upper		A (left-right)	B (top-bottom)
80-4237	XL	81 mm	63 mm
80-4238	L	73 mm	58 mm
80-4239	M	71 mm	52 mm
80-4240	S	67 mm	53 mm
80-4241	XS	65 mm	51 mm

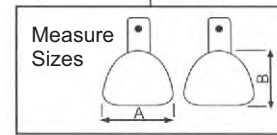

Lower		A (left-right)	B (top-bottom)
80-4242	XL	78 mm	63 mm
80-4243	L	74 mm	62 mm
80-4244	M	72 mm	59 mm
80-4245	S	70 mm	57 mm
80-4246	XS	69 mm	55 mm

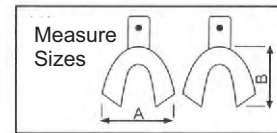

XL L M S XS



RAS-80-4242 RAS-80-4243 RAS-80-4244 RAS-80-4245 RAS-80-4246

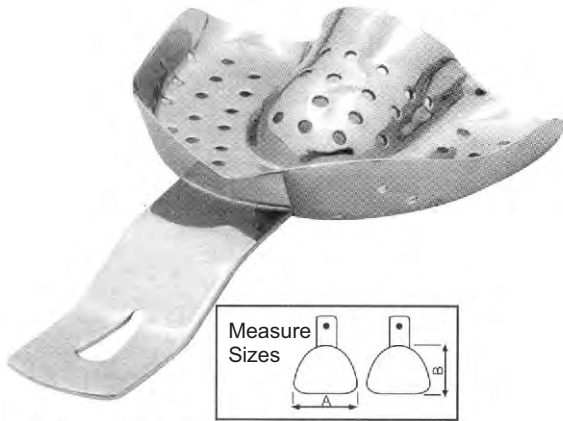

For Toothed Upper Jaws
 (Fig. 0 for children)

	A	B
	mm.	mm.
80-4247	0	59
80-4248	1	66
80-4249	2	71
80-4250	3	71
80-4251	4	80

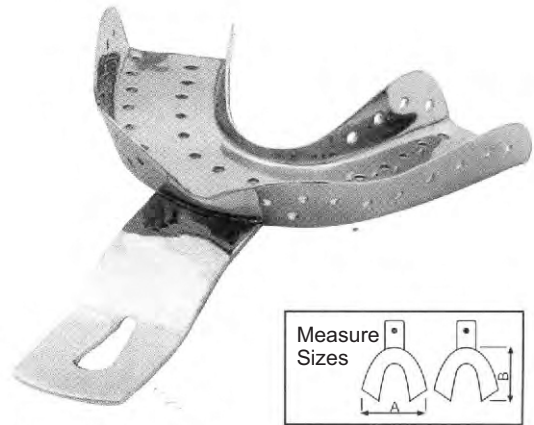

For Toothed Lower Jaws
 (Fig. 0 for children)

	A	B
	mm.	mm.
80-4252	0	65
80-4253	1	67
80-4254	2	76
80-4255	3	79
80-4256	4	79



For Narrow Toothed Upper Jaws

	A	B
	mm.	mm.
80-4257	2	70

- EN** Impression Trays Perforated without Rim Lock
DE Abdrucklöffel perforiert ohne Rim Lock
ES Bandejas de impresión perforadas sin borde de bloqueo
FR Plateaux d'empreinte perforés sans verrouillage de la jante
IT Vassoi per impronta perforati senza cerchia



For partially toothed upper jaws

	A mm.	B mm.
RAS-80-4258	62	50
RAS-80-4259	70	56

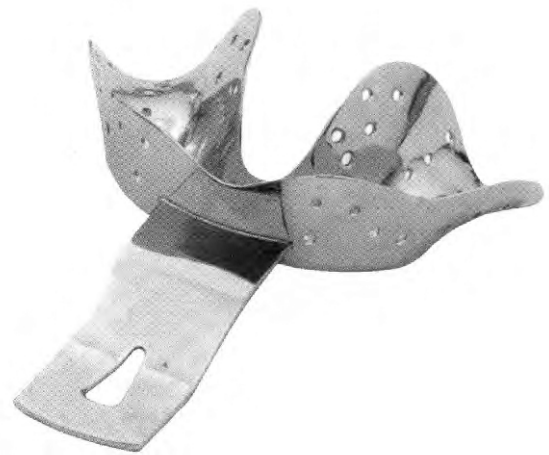
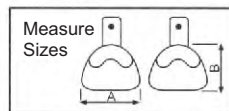

For partially toothed lower jaws

	A mm.	B mm.
RAS-80-4260	70	55
RAS-80-4261	78	59

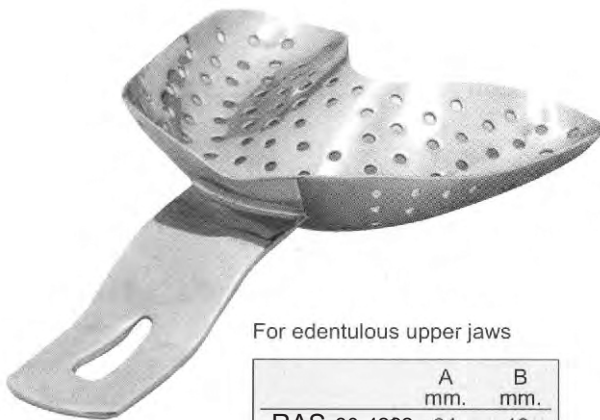
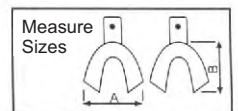

For edentulous upper jaws

	A mm.	B mm.
RAS-80-4262	64	46
RAS-80-4283	68	53
RAS-80-4264	79	61

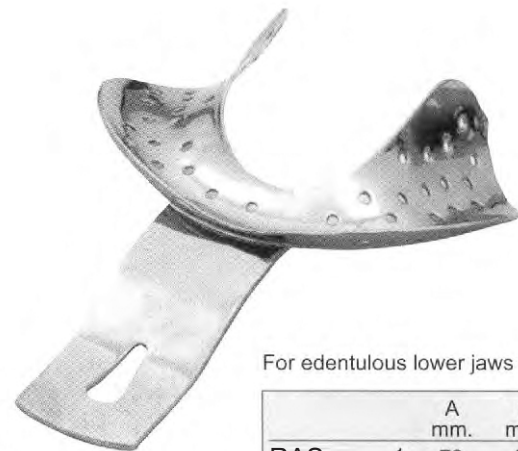

For edentulous lower jaws

	A mm.	B mm.
RAS-80-4265	70	48
RAS-80-4266	70	53
RAS-80-4267	72	57



Solid stainless steel anterior depressed impression trays with retention rim.

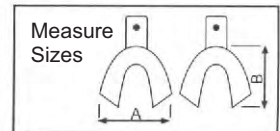
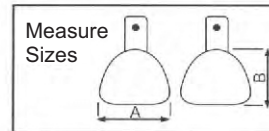

RAS-80-4268 L

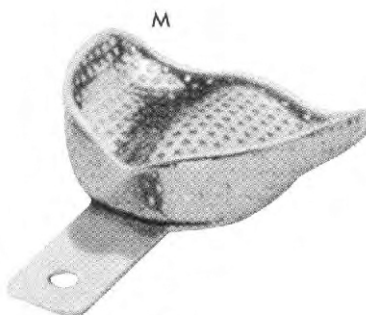

RAS-80-4269 M

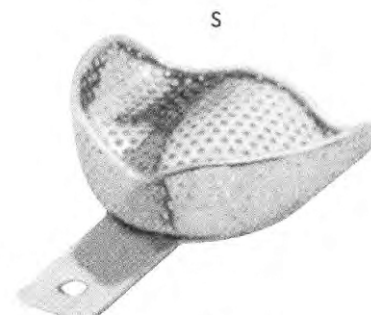

RAS-80-4270 S



RAS-80-4271



RAS-80-4272



RAS-80-4273

	A mm.	B mm.
RAS-80-4268 L	81	67
RAS-80-4269 M	71	64
RAS-80-4270 S	70	57

	A mm.	B mm.
RAS-80-4271 L	81	60
RAS-80-4272 M	79	57
RAS-80-4273 S	76	54

EN Impression Trays Perforated Full Denture
DE Abdrucklöffel perforierte Vollprothese
ES Bandeja de impresión con dentadura completa perforada
FR Impression Trays Perforé Prothèse complète
IT Vassoi per impronte Dentatura piena perforata

IMPRESSION TRAYS



Solid total denture stainless steel impression trays with rim.

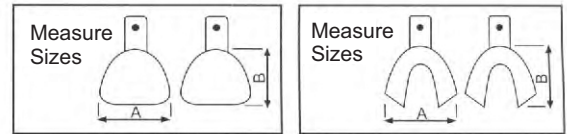

RAS-80-4274

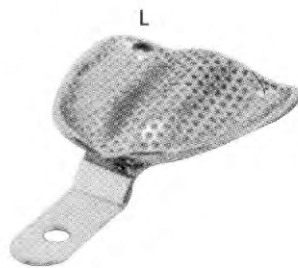

RAS-80-4275

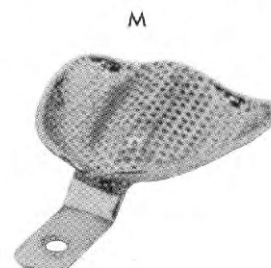

RAS-80-4276

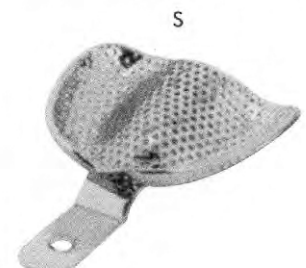

RAS-80-4277



RAS-80-4278

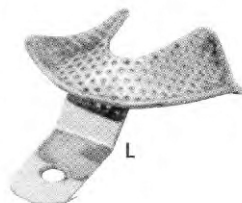

RAS-80-4279

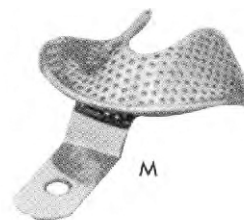

RAS-80-4280

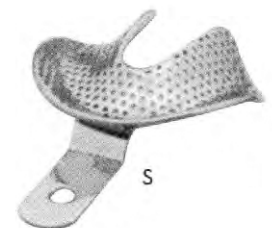

RAS-80-4281

	A mm.	B mm.
RAS-80-4274 XL	79	70
RAS-80-4275 L	76	67
RAS-80-4276 M	70	64
RAS-80-4277 S	73	60

	A mm.	B mm.
RAS-80-4278 XL	86	64
RAS-80-4279 L	70	64
RAS-80-4280 M	73	60
RAS-80-4281 S	70	57



Solid stainless steel anterior depressed impression trays with retention rim.

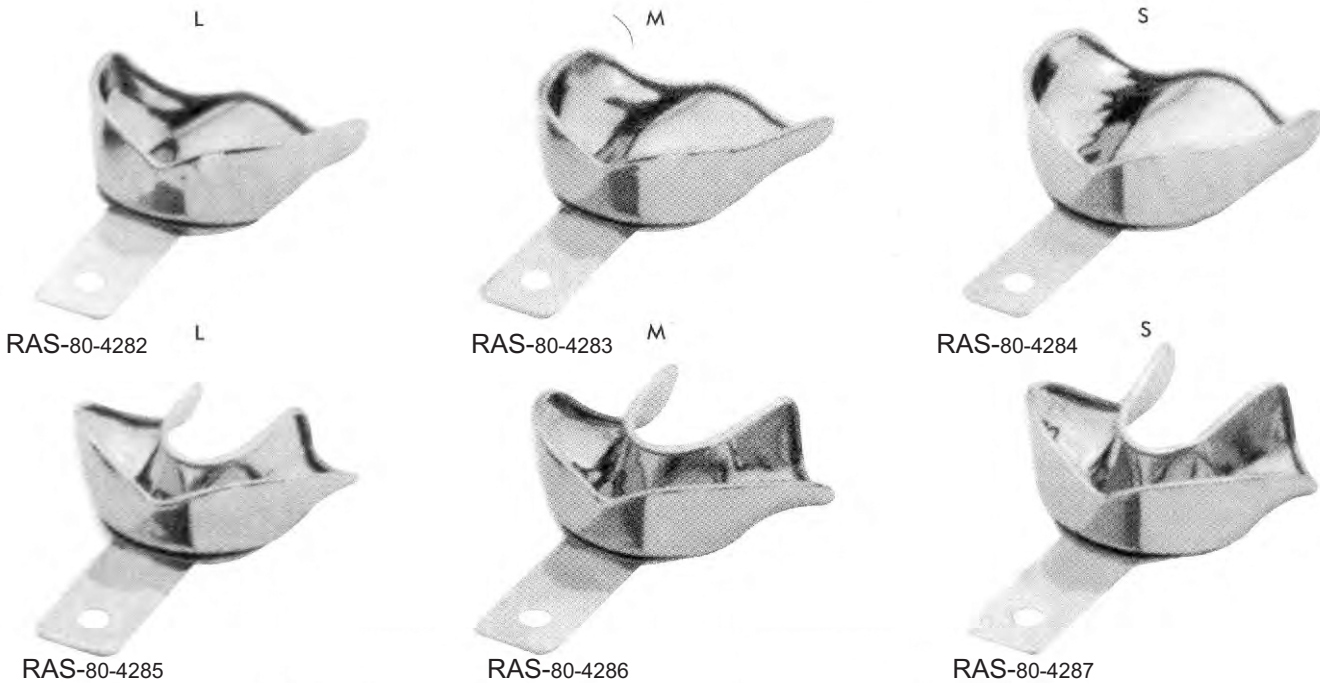
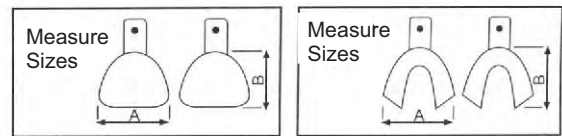

	A	B
	mm.	mm.
RAS-80-4282 L	81	67
RAS-80-4283 M	71	64
RAS-80-4284 S	70	57

	A	B
	mm.	mm.
RAS-80-4285 L	81	60
RAS-80-4286 M	79	57
RAS-80-4287 S	76	54

- EN** Impression Trays Solid Full Denture
- DE** Abdrucklöffel Solid Full Denture
- ES** Bandejas de impresión Solid Full Denture
- FR** Impression Trays pleine prothèse complète
- IT** Impressione vassoi piena protesi totale

IMPRESSION TRAYS



Solid total denture stainless steel impression trays with rim.

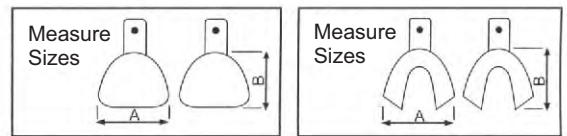

RAS-80-4288

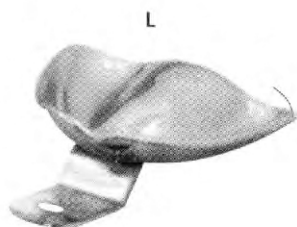

RAS-80-4289

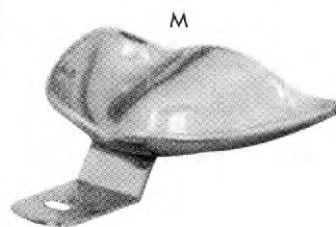

RAS-80-4290

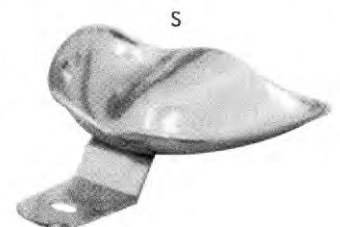

RAS-80-4291



RAS-80-4292



RAS-80-4293

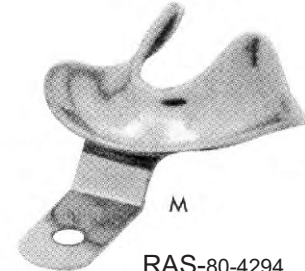

RAS-80-4294



RAS-80-4295

	A mm.	B mm.
RAS-80-4288 XL	79	70
RAS-80-4289 L	76	67
RAS-80-4290 M	70	64
RAS-80-4291 S	73	60

	A mm.	B mm.
RAS-80-4292 XL	86	64
RAS-80-4293 L	70	64
RAS-80-4294 M	73	60
RAS-80-4295 S	70	57



RAS-80-4296



RAS-80-4297



RAS-80-4298



RAS-80-4299



RAS-80-4300

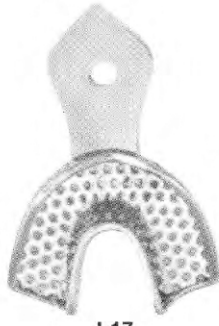

RAS-80-4301

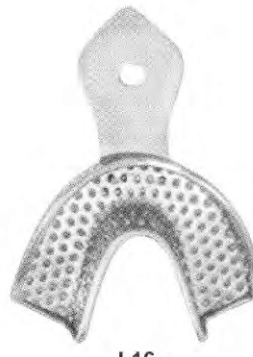

RAS-80-4302



RAS-80-4303



RAS-80-4304



RAS-80-4305



RAS-80-4306



RAS-80-4307



RAS-80-4308



RAS-80-4309



RAS-80-4310



RAS-80-4311

EN	Impression Trays
DE	Knochenfeilen
ES	Limes à os
FR	Plateaux d'impression
IT	Vassoi per le impressioni

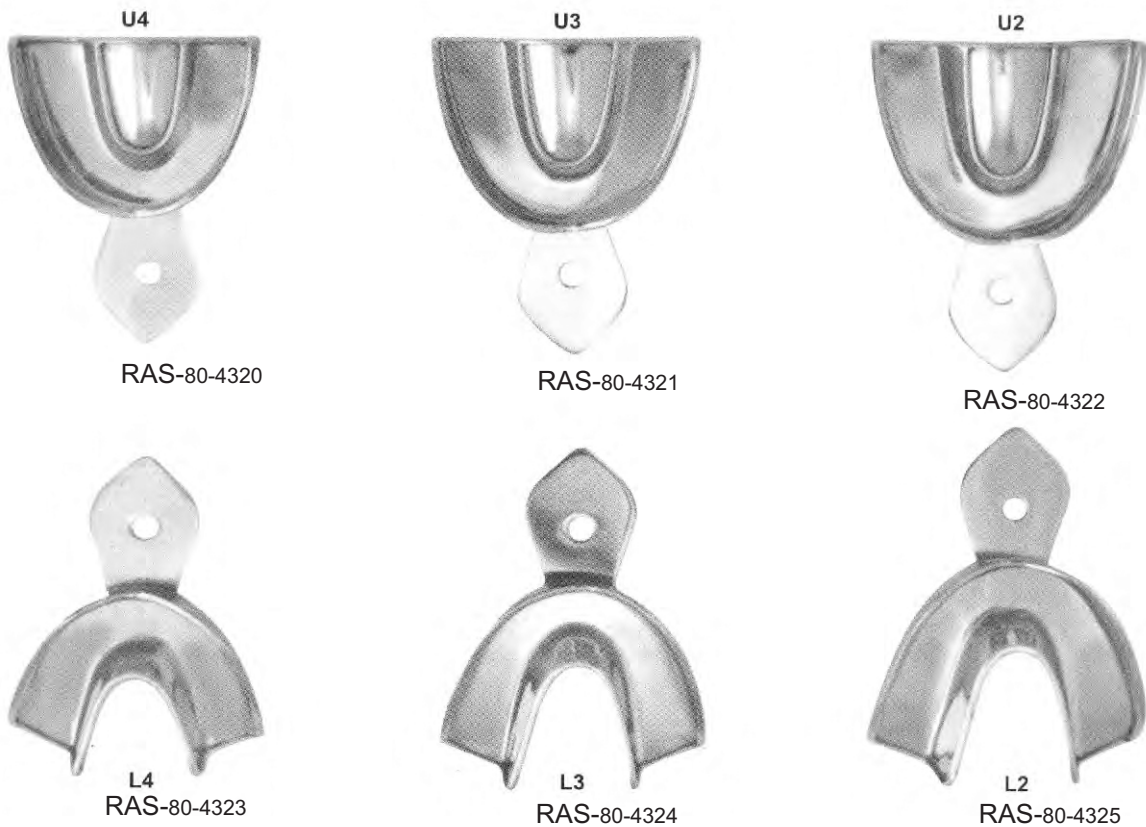
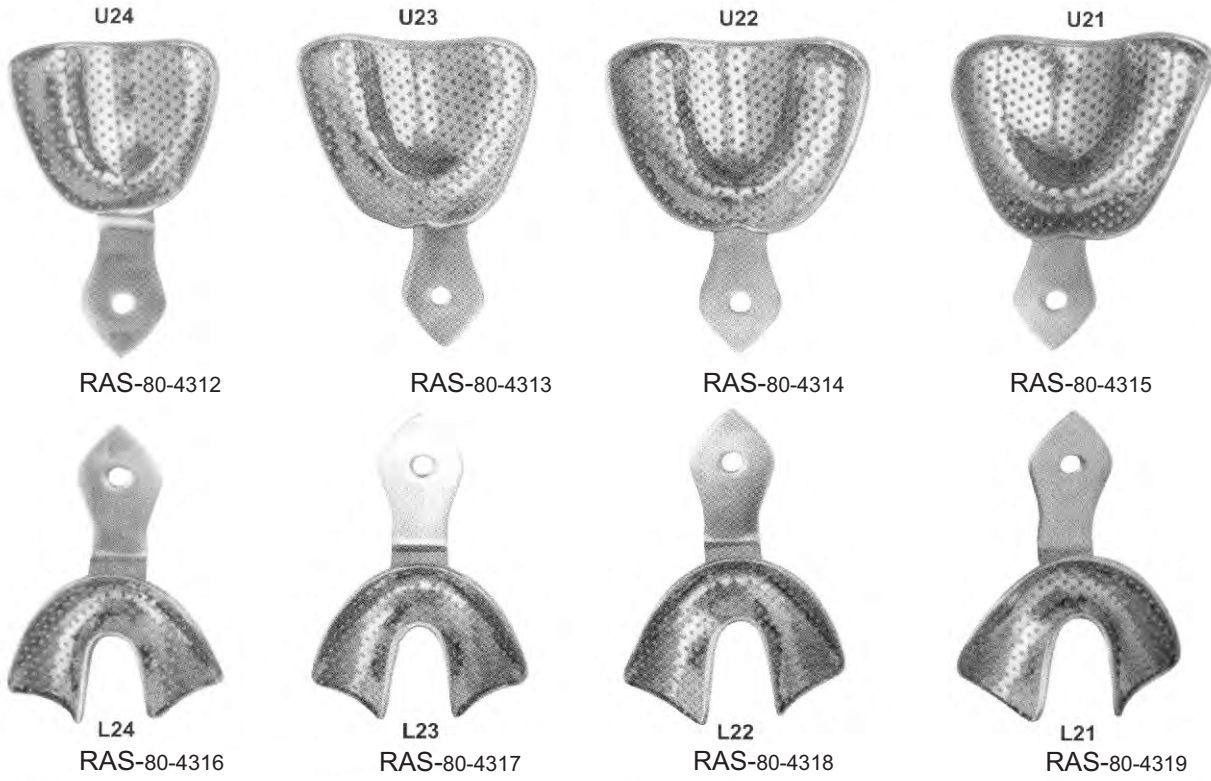



U4

RAS-80-4326

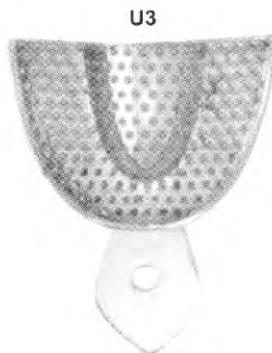

U3

RAS-80-4327



U2

RAS-80-4328

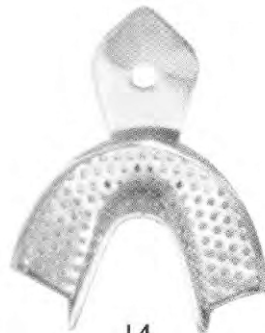

L4

RAS-80-4329

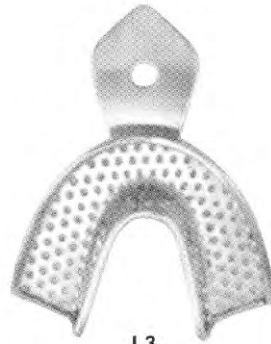

L3

RAS-80-4330



L2

RAS-80-4331



U15

RAS-80-4332



U16

RAS-80-4333



U17

RAS-80-4334



U18

RAS-80-4335



L15

RAS-80-4336



L16

RAS-80-4337

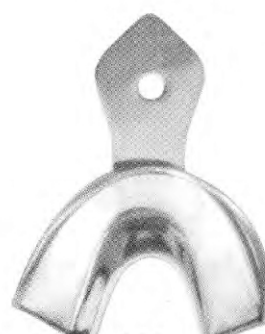

L17

RAS-80-4338



L18

RAS-80-4339

- EN** Articulators
- DE** Artikulatoren
- ES** Articuladores
- FR** Articulateurs
- IT** articolatori

Page 229 to 230



EN	Articulators
DE	Artikulatoren
ES	Articuladores
FR	Articulateurs
IT	articulatori

ARTICULATORS



RAS-81-4301



RAS-81-4302



RAS-81-4303



RAS-81-4304



RAS-81-4306



RAS-81-4305

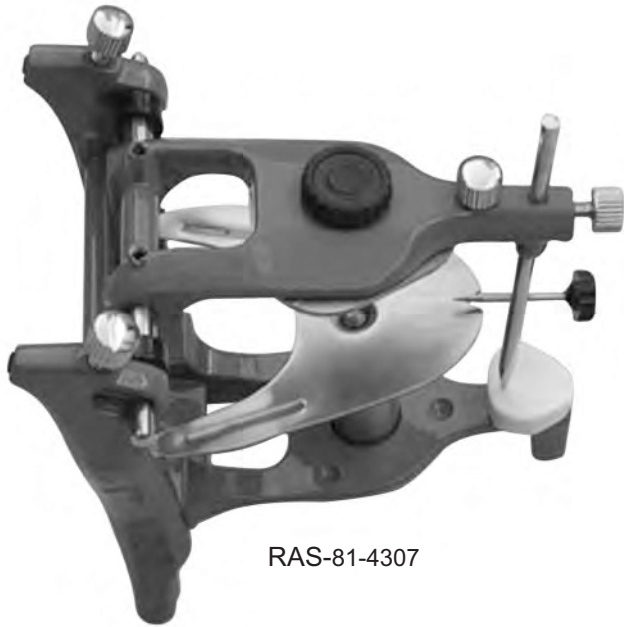

RAS-81-4307



RAS-81-4308



RAS-81-4309



RAS-81-4310



RAS-81-4311



RAS-81-4312



RAS-81-4313



DENTAL
INSTRUMENTS

Office: Defence road , sardarpura
Sialkot 51310 Pakistan
Phone: +92 334 1116870
Email: info@exaktmfgco.com